

RGBlink Science & Technology Co.,Ltd**EMC REPORT**

Applicant	RGBlink Science & Technology Co.,Ltd
Address	Room 601A, No. 37-3 Banshang community, Building 3, Xinke Plaza, Torch Hi-Tech Industrial Development Zone, Xiamen, China
Product Name	Video Mixer
Trademark	
Model Number	mini-pro
Additional Models	mini-mx, mini-max, mini-pro 2022, mini 2022, mini-ultra, mini-mx delta, mini-mx titan, mini-mx atlas, mini-mx apollo, mini-mx orion
Test Laboratory	Shenzhen Circle Testing Certification Co., Ltd.
Address	101,302, Building 1, Donglongxing Technology Park, Huaning Road, Longhua District, Shenzhen, Guangdong, China
Test Date	Aug. 26, 2023 - Aug. 31, 2023
Date of Report	Aug. 31, 2023
Report Number	CTC025G08122ER

TABLE OF CONTENTS

TEST REPORT DECLARATION	4
1. TEST RESULTS SUMMARY	5
2. GENERAL INFORMATION	5
2.1. Report information	5
2.2. Measurement Uncertainty	5
3. PRODUCT DESCRIPTION	6
3.1. EUT Description	6
3.2. Block Diagram of EUT Configuration	6
3.3. Operating Condition of EUT	6
3.4. Test Conditions	6
3.5. Modifications	6
3.6. Abbreviations	7
3.7. Performance Criterion	7
4. TEST EQUIPMENT USED	7
4.1. For Conducted Emission Test	7
4.2. For Magnetic Test (In Shielding Room)	7
4.3. For Radiated Emission Measurement	8
4.4. For Harmonic / Flicker Test	8
4.5. For Electrostatic Discharge Immunity Test	8
4.6. For RF Strength Susceptibility Test	8
4.7. For Electrical Fast Transient/Burst Immunity Test	8
4.8. For Surge Test	8
4.9. For Injected Currents Susceptibility Test	8
4.10. For Magnetic Field Immunity Test	9
4.11. For Voltage Dips and Interruptions Test	9
5. POWER LINE CONDUCTED EMISSION TEST	10
5.1. Block Diagram of Test Setup	10
5.2. Test Standard	10
5.3. Power Line Conducted Emission Limit	10
5.4. EUT Configuration on Test	10
6. RADIATED EMISSION TEST	11
6.1 Semi-Anechoic Chamber Setup Diagram	11
6.2 Test Standard	11
6.3 Radiated Emission Limit	11
6.4 EUT Configuration on Test	11
6.5 Operating Condition of EUT	12
6.6 Test Procedure	12
6.7 Test Results	12
7. HARMONIC CURRENT EMISSION TEST	12
7.1 Block Diagram of Test Setup	12
7.2 Test Standard	12
7.3 Operating Condition of EUT	12
7.4 Test Procedure	13
7.5 Test Results	13
8. VOLTAGE FLUCTUATIONS & FLICKER TEST	13
8.1 Block Diagram of Test Setup	13
8.2 Test Standard	13
8.3 Operating Condition of EUT	13
8.4 Test Data	13
8.5 Test Results	13
9. ELECTROSTATIC DISCHARGE TEST	14
9.1. Block Diagram of ESD Test Setup	14
9.2. Test Standard	14
9.3. Severity Levels and Performance Criterion	14
9.4. EUT Configuration on Test	14
9.5. Operating Condition of EUT	14
9.6. Test Procedure	14



9.7. Test Results 15

10. RF FIELD STRENGTH SUSCEPTIBILITY TEST 16

 10.1. R/S Test Setup 16

 10.2. Test Standard 16

 10.3. Severity Levels and Performance Criterion 16

 10.4. EUT Configuration on Test 16

 10.5. Operating Condition of EUT 16

 10.6. Test Procedure 16

 10.7. Test Results 17

11. ELECTRICAL FAST TRANSIENT/BURST TEST 17

 11.1. EFT Test Setup 17

 11.2. Test Standard 18

 11.3. Severity Levels and Performance Criterion 18

 11.4. EUT Configuration on Test 18

 11.5. Operating Condition of EUT 18

 11.6. Test Procedure 18

 11.7. Test Results 19

12. SURGE TEST 19

 12.1. Surge Test Setup 19

 12.2. Test Standard 19

 12.3. Severity Levels and Performance Criterion 19

 12.4. EUT Configuration on Test 20

 12.5. Operating Condition of EUT 20

 12.6. Test Procedure 20

 12.7. Test Results 20

13. INJECTED CURRENTS SUSCEPTIBILITY TEST 21

 13.1. Block Diagram of Test AC Mains Setup 21

 13.2. Test Standard 21

 13.3. Severity Levels and Performance Criterion 21

 13.4. EUT Configuration on Test 21

 13.5. Operating Condition of EUT 21

 13.6. Test Procedure 22

 13.7. Test Results 22

14. MAGNETIC FIELD IMMUNITY TEST 22

 14.1 Block Diagram of Test Setup 22

 14.2 Test Standard 22

 14.3 Severity Levels and Performance Criterion 23

 14.4 EUT Configuration on Test 23

 14.5 Operating Condition of EUT 23

 14.6 Test Procedure 23

 14.7 Test Results 23

15. VOLTAGE DIPS AND INTERRUPTIONS TEST 24

 15.1. Voltage Dips and Interruptions Test Setup 24

 15.2. Test Standard 24

 15.3. Severity Levels and Performance Criterion 24

 15.4. EUT Configuration on Test 24

 15.5. Operating Condition of EUT 24

 15.6. Test Procedure 24

 15.7. Test Result 25

APPENDIX I : CONDUCTED EMISSION TEST DATA 26

APPENDIX II: RADIATED EMISSION TEST DATA 28

APPENDIX III: HARMONIC EMISSION TEST DATA 30

APPENDIX IV: FLICKER TEST DATA 33

APPENDIX V: EUT AND TEST SETUP PHOTO 34

TEST REPORT DECLARATION

Applicant	RGBlink Science & Technology Co.,Ltd
Address	Room 601A, No. 37-3 Banshang community, Building 3, Xinke Plaza, Torch Hi-Tech Industrial Development Zone, Xiamen, China
EUT Description	Video Mixer
Model Number	See page 1

Test Standards:

- EN 55032:2015+A11:2020
- EN 55035:2017+A11:2020
- EN IEC 61000-3-2:2019+A1:2021
- EN 61000-3-3:2013+A1:2019

The EUT described above is tested by Shenzhen Circle Testing Certification Co., Ltd. EMC Laboratory to determine the maximum emissions from the EUT and ensure the EUT to be compliance with the immunity requirements of the EUT. Shenzhen Circle Testing Certification Co., Ltd. EMC Laboratory is assumed full responsibility for the accuracy of the test results. Also, this report shows that the EUT technically complies with the 2014/30/EU directive and its amendment requirements.

The test report is valid for above tested sample only and shall not be reproduced in part without written approval of the laboratory.

Tested by :

Kara

Test Engineer

Approved & Authorized Signer :



1. TEST RESULTS SUMMARY

Table 1 Test Results Summary

Test Items	Test Results
Power Line Conducted Emission Test	PASS
Magnetic Test	PASS
Radiated Emission	PASS
Harmonic Current Emission Test	PASS
Voltage Fluctuations & Flicker Test	PASS
Electrostatic Discharge Test	PASS
RF Field Strength Susceptibility Test	PASS
Electrical Fast Transient/Burst Test	PASS
Surge Test	PASS
Injected Currents Susceptibility Test	PASS
Magnetic Field Immunity Test	PASS
Voltage Dips And Interruptions Test	PASS

2. GENERAL INFORMATION

2.1. Report information

- 2.1.1. This report is not a certificate of quality; it only applies to the sample of the specific product/equipment given at the time of its testing. The results are not used to indicate or imply that they are application to the similar items. In addition, such results must not be used to indicate or imply that CTC approves recommends or endorses the manufacture, supplier or use of such product/equipment, or that CTC in any way guarantees the later performance of the product/equipment.
- 2.1.2. The sample/s mentioned in this report is/are supplied by Applicant, CTC therefore assumes no responsibility for the accuracy of information on the brand name, model number, origin of manufacture or any information supplied.
- 2.1.3. Additional copies of the report are available to the Applicant at an additional fee. No third part can obtain a copy of this report through CTC, unless the applicant has authorized CTC in writing to do so.

2.2. Measurement Uncertainty

(95% confidence levels, k=2)

Test Item	Uncertainty
Uncertainty for Conduction emission test	2.2dB

Uncertainty for Magnetic emission test	3.3dB
Uncertainty for Radiation emission test (30MHz to 1GHz)	4.0dB

3. PRODUCT DESCRIPTION

3.1. EUT Description

EUT Description	Video Mixer
Applicant	RGBlink Science & Technology Co.,Ltd
Address	Room 601A, No. 37-3 Banshang community, Building 3, Xinke Plaza, Torch Hi-Tech Industrial Development Zone, Xiamen, China
Manufacturer	RGBlink Science & Technology Co.,Ltd
Address	Room 601A, No. 37-3 Banshang community, Building 3, Xinke Plaza, Torch Hi-Tech Industrial Development Zone, Xiamen, China
Model Number	mini-pro
Rating(s)	Input: 100-240 VAC, 50/60Hz, 18W Output: 12VDC

3.2. Block Diagram of EUT Configuration



3.3. Operating Condition of EUT

Test mode 1: Normal operation

3.4. Test Conditions

Temperature: 22-26°C
Relative Humidity: 55-60%
Atmospheric pressure: 101kPa

3.5. Modifications

No modification was made.

3.6. Abbreviations

AC	Alternating Current
AMN	Artificial Mains Network
DC	Direct Current
EM	ElectroMagnetic
EMC	ElectroMagnetic Compatibility
EUT	Equipment Under Test
IF	Intermediate Frequency
RF	Radio Frequency
rms	root mean square
EMI	Electromagnetic Interference
EMS	Electromagnetic Susceptibility

3.7. Performance Criterion

Criterion A: The equipment shall continue to operate as intended without operator intervention. No degradation of performance or loss of function is allowed below a performance level specified by the manufacturer when the equipment is used as intended.

Criterion B: After the test, the equipment shall continue to operate as intended without operator intervention. No degradation of performance or loss of function is allowed, after the application of the phenomena below a performance level specified by the manufacturer, when the equipment is used as intended.

Criterion C: Loss of function is allowed, provided the function is self-recoverable, or can be restored by the operation of the controls by the user in accordance with the manufacturer's instructions.

4. TEST EQUIPMENT USED

4.1. For Conducted Emission Test

Item	Equipment	Manufacturer	Model No.	Serial No.	Last Cal.	Cal. Interval
1.	Test Receiver	Rohde & Schwarz	ESHS30	828985/018	Jun. 01, 24	1 Year
2.	Pulse Limiter	Rohde & Schwarz	ESH3-Z2	100006	Jun. 01, 24	1 Year
3.	L.I.S.N.	Rohde & Schwarz	ESH2-Z5	834549/005	Jun. 01, 24	1 Year
4.	Conical	Emtek	N/A	N/A	N/A	N/A
5.	Voltage Probe	Schwarzbeck	TK9416	N/A	Jun. 01, 24	1 Year
6.	Coaxial Switch	Anritsu	MP59B	6100214550	Jun. 01, 24	1 Year

4.2. For Magnetic Test (In Shielding Room)

Item	Equipment	Manufacturer	Model No.	Serial No.	Last Cal.	Cal. Interval
1.	Test Receiver	Rohde & Schwarz	ESHS20	836600/006	Jun. 04, 24	1 Year
2.	Triple-loop Antenna	Rohde & Schwarz	HM020	843885/002	Jun. 05, 24	1 Year
3.	RF Cable	MIYAZAKI	5D-2W	Tri-loop Cable	Jun. 28, 24	1/2 Year
4.	Coaxial Switch	Anritsu	MP59B	M73989	Jun. 04, 24	1/2 Year

4.3. For Radiated Emission Measurement

Item	Equipment	Manufacturer	Model No.	Serial No.	Last Cal.	Cal. Interval
1.	Spectrum Analyzer	ANRITSU	MS2661C	6200140915	Jun. 01, 24	1 Year
2.	Test Receiver	Rohde&Schwarz	ESC830	828982/018	Jun. 01, 24	1 Year
3.	Bilog Antenna	Schwarzbeck	VULB9163	142	Jun. 01, 24	1 Year
4.	50 Coaxial Switch	Anritsu Corp	MP59B	6100237248	Jun. 01, 24	1 Year
5.	Cable	Schwarzbeck	AK9513	ACRX1	Jun. 01, 24	1 Year
6.	Cable	Rosenberger	N/A	FR2RX2	Jun. 01, 24	1 Year
7.	Cable	Schwarzbeck	AK9513	CRRX2	Jun. 01, 24	1 Year
8.	Cable	Schwarzbeck	AK9513	CRRX2	Jun. 01, 24	1 Year
9.	Signal Generator	HP	864A	3625U00573	Jun. 01, 24	1 Year

4.4. For Harmonic / Flicker Test

Item	Equipment	Manufacturer	Model No.	Serial No.	Last Cal.	Cal. Interval
1.	Harmonic and Flicker analyzer	Laplace	AC2000A	309709	Oct. 15, 2024	1 Year

4.5. For Electrostatic Discharge Immunity Test

Item	Equipment	Manufacturer	Model No.	Serial No.	Last Cal.	Cal. Interval
1.	ESD Tester	HAEFELY	PSD 1600	H911'292	Jun. 02, 24	1 Year

4.6. For RF Strength Susceptibility Test

Item	Equipment	Manufacturer	Model No.	Serial No.	Last Cal.	Cal. Interval
1.	Signal Generator	HP	8648A	3633A02081	Jun. 03, 24	1 Year
2.	Amplifier	A&R	500A100	17034	NCR	NCR
3.	Amplifier	A&R	100W/1000M1	17028	NCR	NCR
4.	Isotropic Field Monitor	A&R	FM2000	16829	NCR	NCR
5.	Isotropic Field Probe	A&R	FLW220100	16755	Jun. 03, 24	1 Year
6.	Biconic Antenna	EMCO	3108	9507-2534	NCR	NCR
7.	Log-periodic Antenna	A&R	AT1080	16812	NCR	NCR
8.	PC	N/A	486DX2	N/A	N/A	N/A

4.7. For Electrical Fast Transient/Burst Immunity Test

Item	Equipment	Manufacturer	Model No.	Serial No.	Last Cal.	Cal. Interval
1.	Burst Tester	HAEFELY	PEFT 4010	080981-16	Jun. 01, 24	1 Year

4.8. For Surge Test

Item	Equipment	Manufacturer	Model No.	Serial No.	Last Cal.	Cal. Interval
1.	Surge Tester	HAEFELY	PSURGE4.1	080107-04	Jun. 01, 24	1 Year

4.9. For Injected Currents Susceptibility Test

Item	Equipment	Manufacturer	Model No.	Serial No.	Last Cal.	Cal. Interval
1.	Simulator	EMTEST	CWS 500C	0900-12	Jun. 01, 24	1 Year
2.	CDN	EMTEST	CDN-M2	510010010010	Jun. 01, 24	1 Year
3.	VDN	EMTEST	CDN-M3	0900-11	Jun. 01, 24	1 Year
4.	Injection Clamp	EMTEST	F-2031-23MM	368	Jun. 01, 24	1 Year
5.	Attenuator	EMTEST	ATT6	0010222a	Jun. 01, 24	1 Year

4.10. For Magnetic Field Immunity Test

Item	Equipment	Manufacturer	Model No.	Serial No.	Last Cal.	Cal. Interval
1.	Magnetic Field Tester	HEAFELY	MAG100.1	083858-10	Jun. 01, 24	1 Year

4.11. For Voltage Dips and Interruptions Test

Item	Equipment	Manufacturer	Model No.	Serial No.	Last Cal.	Cal. Interval
1.	Dips Tester	HEAFELY	PLINE 1610	083732-18	Jun. 01, 24	1 Year

5. POWER LINE CONDUCTED EMISSION TEST

5.1. Block Diagram of Test Setup

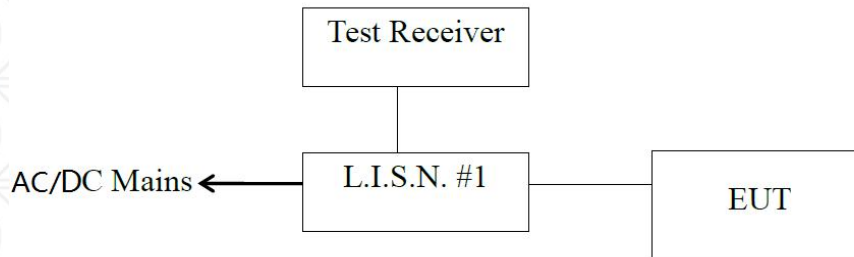

5.2. Test Standard

EN 55032:2015+A11:2020 Class B

5.3. Power Line Conducted Emission Limit

Frequency MHz	Limits dB(uV)	
	Quasi-peak Level	Average Level
0.15-0.50	66-56	56-46
0.50-5.0	56	46
5.0-30	60	50

Notes: 1.*Decreasing linearly with logarithm of frequency.

2.The lower limit shall apply at the transition frequencies.

5.4. EUT Configuration on Test

The following equipment are installed on conducted emission test to meet EN 55032 requirement and operating in a manner, which tends to maximize its emission characteristics in a normal application.

5.5. Operating Condition of EUT

5.5.1.Setup the EUT and simulators as shown in Section 5.1.

5.5.2.Turn on the power of all equipment.

5.5.3.Let the EUT work in test modes (ON) and test it.

5.6. Test Procedure

The EUT is put on the ground and connected to the AC/DC mains through a Artificial Mains Network (AMN). This provided 50ohm-coupling impedance for the tested equipment. Both sides of AC/DC line are checked to find out the maximum conducted emission levels according to the EN 55032 regulations during conducted emission test.

The bandwidth of the test receiver is set at 9kHz.

The frequency range from 150 kHz to 30 MHz is investigated. and all the scanning waveform is put in **Appendix I**.

5.7. Test Result

PASS.

6. RADIATED EMISSION TEST

6.1 Semi-Anechoic Chamber Setup Diagram

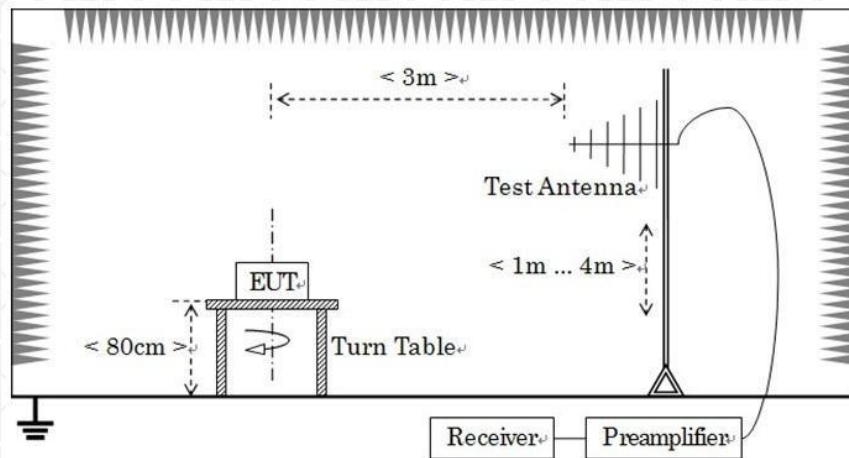

6.2 Test Standard

EN 55032:2015+A11:2020 Class B

6.3 Radiated Emission Limit

All emanations from a Class B computing devices or system, including any network of conductors and apparatus connected thereto, shall not exceed the level of field strengths specified below:

FREQUENCY (MHz)	DISTANCE (Meters)	FIELD STRENGTHS LIMITS (dBuV/m)
30-230	3	40
230-1000	3	47

- Note:(1) The tighter limit shall apply at the edge between two frequency bands.
 (2) Distance refers to the distance in meters between the measuring instruments antenna and the closed point of any part of the EUT.

6.4 EUT Configuration on Test

The EN 55032 Class B regulations test method must be used to find the maximum emission during radiated emission test.

6.5 Operating Condition of EUT

- 6.5.1. Setup the EUT as shown on Section 6.1.
- 6.5.2. Turn on the power of all equipment.
- 6.5.3. Let the EUT work in test mode (ON) and measure it.

6.6 Test Procedure

The EUT is placed on a turn table which is 0.8 meter above ground. The turn table can rotate 360 degrees to determine the position of the maximum emission level. The EUT is set 3 meters away from the receiving antenna which is mounted on a antenna tower. The antenna can move up and down between 1 to 4 meters to find out the maximum emission level. Broadband antenna (calibrated by dipole antenna) are used as a receiving antenna. Both horizontal and vertical polarization of the antenna are set on test. The bandwidth setting on the test receiver is 120 kHz. The EUT is tested in Semi-Anechoic Chamber. and all the scanning waveform is put in **Appendix I**.

6.7 Test Results

PASS.

7. HARMONIC CURRENT EMISSION TEST

7.1 Block Diagram of Test Setup

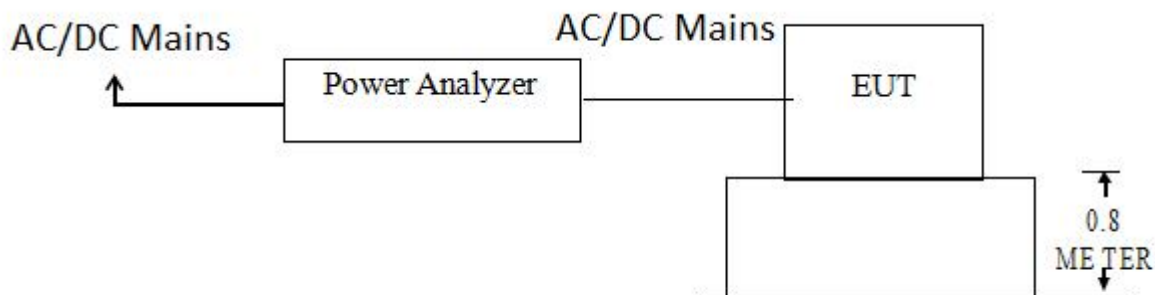

7.2 Test Standard

EN IEC 61000-3-2:2019+A1:2021

7.3 Operating Condition of EUT

- 7.3.1. Setup the EUT as shown in Section 7.1.
- 7.3.2. Turn on the power of all equipments.
- 7.3.3. Let the EUT work in test mode (ON) and test it.

7.4 Test Procedure

The power cord of the EUT is connected to the output of the test system. Turn on the Power of the EUT and use the test system to test the harmonic current level.

7.5 Test Results

PASS, Data see **Appendix III**.

8. VOLTAGE FLUCTUATIONS & FLICKER TEST

8.1 Block Diagram of Test Setup

Same as Section 7.1.

8.2 Test Standard

EN 61000-3-3:2013+A1:2019

8.3 Operating Condition of EUT

Same as Section 8.3. The power cord of the EUT is connected to the output of the test system. Turn on the power of the EUT and use the test system to test.

Flicker Test Limit

Test items	Limits
Pst	1.0
dc	3.3%
dmax	4.0%
dt	Not exceed 3.3% for 500ms

8.4 Test Data

Test Mode: 1		
Items	Reading	Limit
dmax	0.01	4.0%
dc	0.03	3.3%
dt	0.05	Not exceed 3.3% for 500ms
Pst	0.001	1.0

8.5 Test Results

PASS, Data see **Appendix IV**.

9. ELECTROSTATIC DISCHARGE TEST

9.1. Block Diagram of ESD Test Setup

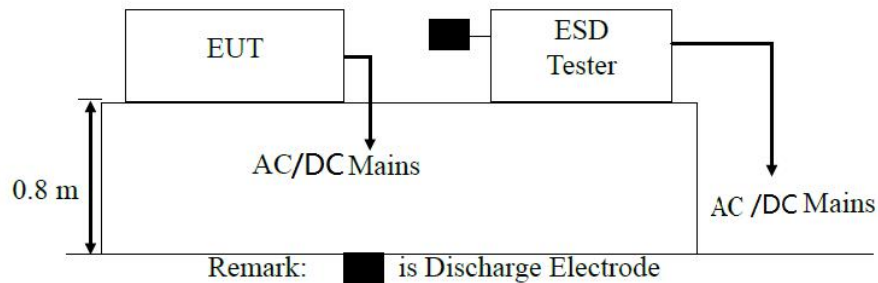

9.2. Test Standard

EN 55035:2017+A11:2020
 Severity Level 3 for Air Discharge at 8kV
 Severity Level 2 for Contact Discharge at 4kV

9.3. Severity Levels and Performance Criterion

9.3.1. Severity level

Level	Test Voltage	Test Voltage
	Contact Discharge (kV)	Air Discharge (kV)
1.	2	2
2.	4	4
3.	6	8
4.	8	15
X.	Special	Special

9.3.2. Performance criterion: B

9.4. EUT Configuration on Test

The configuration of EUT are listed in Section 3.2.

9.5. Operating Condition of EUT

- 9.5.1. Setup the EUT as shown in Section 9.1.
- 9.5.2. Turn on the power of all equipment.
- 9.5.3. Let the EUT work in test mode (On) and test it.

9.6. Test Procedure

9.6.1. Air Discharge:

This test is done on a non-conductive surfaces. The round discharge tip of the discharge electrode shall be approached as fast as possible to touch the EUT. After each discharge, the discharge electrode shall be removed from the EUT. The generator is then re-triggered for a new single discharge and repeated 10 times for each pre-selected test point. This procedure shall be repeated until all the air discharge completed.

9.6.2. Contact Discharge:

All the procedure shall be same as Section 9.6.1. except that the tip of the discharge electrode shall touch the EUT before the discharge switch is operated.

9.6.3. Indirect discharge for horizontal coupling plane

At least 20 single discharges shall be applied to the horizontal coupling plane, at points on each side of the EUT. The discharge electrode positions vertically at a distance of 0.1m from the EUT and with the discharge electrode touching the coupling plane.

9.6.4. Indirect discharge for vertical coupling plane

At least 20 single discharge shall be applied to the center of one vertical edge of the coupling plane. The coupling plane, of dimensions 0.5m X 0.5m, is placed parallel to, and positioned at a distance of 0.1m from the EUT. Discharges shall be applied to the coupling plane, with this plane in sufficient different positions that the four faces of the EUT are completely illuminated.

9.7. Test Results

Temperature	22°C	Humidity	50%
Air Discharge: ±8kV For each point positive 10 times and negative 10 times discharge. Contact Discharge: ±4kV			
Location	Kind A-Air Discharge C-Contact Discharge		Result
HCP	C		PASS
VCP	C		PASS
Product surface	A		PASS
Gap	A		PASS
Metal housing	C		PASS
Power cord	A		PASS
Type-C interface	C		PASS

Discharge should be considered on Contact and Air and Horizontal Coupling Plane (HCP) and Vertical Coupling Plane (VCP).

10. RF FIELD STRENGTH SUSCEPTIBILITY TEST

10.1. R/S Test Setup

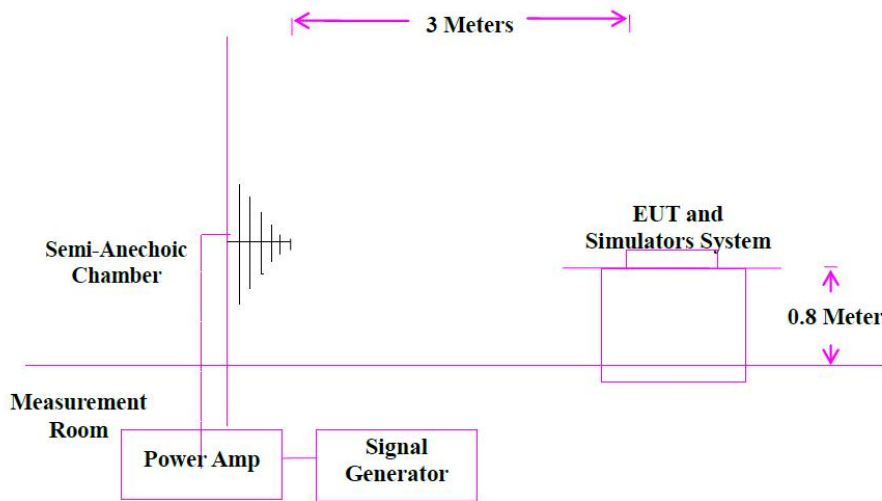

10.2. Test Standard

EN 55035:2017+A11:2020

10.3. Severity Levels and Performance Criterion

10.3.1. Severity level

Level	Field Strength V/m
1.	1
2.	3
3.	10
X.	Special

10.3.2. Performance criterion : A

10.4. EUT Configuration on Test

The configuration of EUT are listed in Section 3.2

10.5. Operating Condition of EUT

Setup the EUT as shown in Section 10.1. The operating condition of EUT are listed in section 3.3.

10.6. Test Procedure

The EUT and its simulators are placed on a turn table which is 0.8 meter above the ground. The EUT is set 3 meters away from the transmitting antenna which is mounted on an

antenna tower. Both horizontal and vertical polarization of the antenna are set on test. Each of the four sides of EUT must be faced this transmitting antenna and measured individually. In order to judge the EUT performance, a CCD camera is used to monitor the EUT. All the scanning conditions are as follows :

Condition of Test	Remarks
1. Fielded Strength	3 V/m (Severity Level 2)
2. Radiated Signal	Modulated
3. Scanning Frequency	80 - 1000 MHz, 1.4GHz-2.7GHz
4. Sweeping time of radiated	0.0015 decade/s
5. Dwell Time	1 Sec.

10.7. Test Results

Temperature	22°C	Humidity	50%
Modulation: <input checked="" type="checkbox"/> AM <input type="checkbox"/> Pulse <input type="checkbox"/> none <input checked="" type="checkbox"/> 1kHz 80%			
Criterion : A			
Frequency Range : 80 MHz to 1000 MHz, 1.4GHz-2.7GHz			
Steps: 1%			
	Horizontal	Vertical	
Front	PASS	PASS	
Right	PASS	PASS	
Rear	PASS	PASS	
Left	PASS	PASS	

11. ELECTRICAL FAST TRANSIENT/BURST TEST

11.1. EFT Test Setup

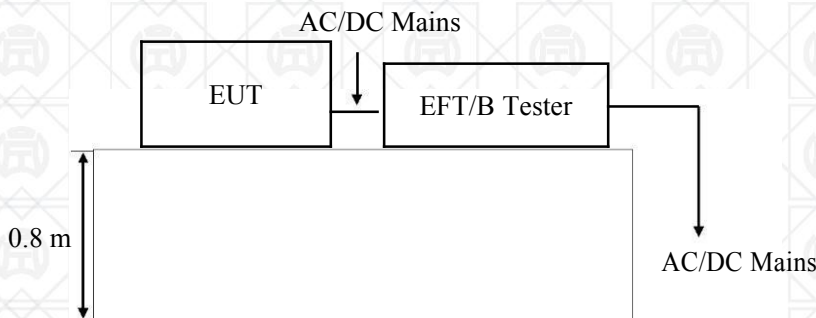

11.2. Test Standard

EN 55035:2017+A11:2020
Severity Level 2 at 1kV

11.3. Severity Levels and Performance Criterion

11.3.1. Severity level

Open Circuit Output Test Voltage $\pm 10\%$		
Level	On Power Supply Lines	On I/O (Input/Output) Signal data and control lines
1.	0.5 kV	0.25 kV
2.	1 kV	0.5 kV
3.	2 kV	1 kV
4.	4 kV	2 kV
X	Special	Special

11.3.2. Performance criterion : B

11.4. EUT Configuration on Test

The configuration of EUT are listed in Section 3.2.

11.5. Operating Condition of EUT

Setup the EUT as shown in Section 11.1. The operating condition of EUT are listed in section 3.3.

11.6. Test Procedure

The EUT is put on the table which is 0.8 meter high above the ground. This reference ground plane shall project beyond the EUT by at least 0.1m on all sides and the minimum distance between the EUT and all other conductive structure, except the ground plane beneath the EUT, shall be more than 0.5m.

11.6.1. For input and output AC power ports:

The EUT is connected to the power mains by using a coupling device which couples the EFT interference signal to AC power lines. Both polarities of the test voltage should be applied during compliance test and the duration of the test is 2 mins.

11.6.2. For signal lines and control lines ports: It's unnecessary to test.

11.6.3. For DC output line ports: It's unnecessary to test.

11.7. Test Results

Temperature	22℃				Humidity	50%			
Power Supply	AC 230V/50Hz				Test Mode	Normal operation			
Inject Place : AC Mains									
Inject Line	Voltage kV	Inject Time(s)	Inject Method	Results	Inject Line	Voltage kV	Inject Time(s)	Inject Method	Results
L	±1	120	Direct	PASS					
N	±1	120	Direct	PASS					
L+N	±1	120	Direct	PASS					
PE	±1	120	Direct	PASS					
L+N+PE	±1	120	Direct	PASS					
L+PE	±1	120	Direct	PASS					
N+PE	±1	120	Direct	PASS					

12. SURGE TEST

12.1. Surge Test Setup

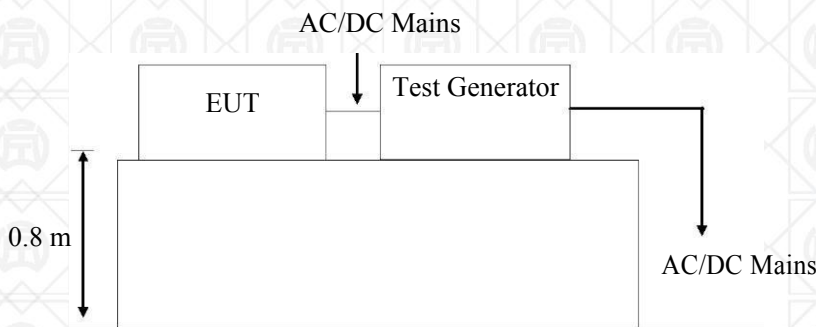

12.2. Test Standard

EN 55035:2017+A11:2020, IEC 61000-4-5:2005
 Severity Level 2 for Line and Linel at 1.0kV
 Severity Level 3 for Line to earth(ground) at 2.0kV

12.3. Severity Levels and Performance Criterion

12.3.1. Severity level

Severity Level	Open-Circuit Test Voltage
	kV
1	0.5
2	1.0
3	2.0
4	4.0
*	Special

Performance criterion : **B**

12.4.EUT Configuration on Test

The configuration of EUT are listed in Section 3.2.

12.5.Operating Condition of EUT

- 12.5.1.Setup the EUT as shown in Section 12.1.
- 12.5.2.Turn on the power of all equipment.
- 12.5.3.Let the EUT work in test mode (On) and test it.

12.6.Test Procedure

1. Setup the EUT and test generator as shown on Section 12.1.
2. For line to line coupling mode, provide a 1.0kV 1.2/50us voltage surge (at open-circuit condition) and 8/20us current surge to EUT selected points.
3. At least 5 positive and 5 negative (polarity) tests with a maximum 1/min repetition rate are conducted during test.
4. Different phase angles are done individually.
5. Record the EUT operating situation during compliance test and decide the EUT immunity criterion for above each test.

12.7.Test Results

Temperature	22°C		Humidity	50%	
Location	Polarity	Phase Angle	No of Pulse	Pulse Voltage (kV)	Result
L-N	+/-	90/270	5	1.0	PASS
L-PE	+/-	90/270	5	2.0	PASS
N-PE	+/-	90/270	5	2.0	PASS
L+N-PE	+/-	90/270	5	2.0	PASS

13.INJECTED CURRENTS SUSCEPTIBILITY TEST

13.1.Block Diagram of Test AC Mains Setup

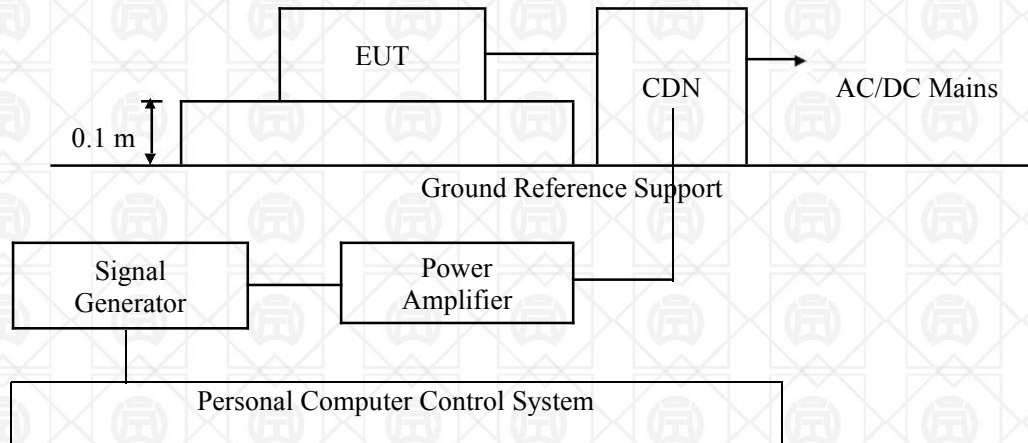

13.2.Test Standard

EN 55035:2017+A11:2020, IEC 61000-4-6:2008
 Severity Level 2 at 3 V (rms), 0.15MHz ~ 30MHz
 Severity Level 1 at 1V (rms), 30MHz ~ 80MHz

13.3.Severity Levels and Performance Criterion

13.3.1.Severity level

Level	Field Strength V/m
1.	1
2.	3
3.	10
X	Special

13.3.2.Performance criterion: A

13.4.EUT Configuration on Test

The configuration of EUT are listed in Section 3.2

13.5.Operating Condition of EUT

Setup the EUT as shown in Section 13.1. The operating condition of EUT are listed in section 3.3

13.6. Test Procedure

1. Set up the EUT, CDN and test generators as shown on Section 13.1.
2. Let the EUT work in test mode and test it.
3. The EUT are placed on an insulating support 0.8m high above a ground reference plane. CDN (coupling and decoupling device) is placed on the ground plane about 0.3m from EUT. Cables between CDN and EUT are as short as possible, and their height above the ground reference plane shall be between 30 and 50 mm (where possible).
4. The disturbance signal described below is injected to EUT through CDN.
5. The EUT operates within its operational mode(s) under intended climatic conditions after power on.
6. The frequency range is swept from 150kHz to 80MHz using 3V signal level, and with the disturbance signal 80% amplitude modulated with a 1kHz sine wave.
7. The rate of sweep shall not exceed 1.5×10^{-3} decades/s. Where the frequency is swept incrementally, the step size shall not exceed 1% of the start and thereafter 1% of the preceding frequency value.
8. Recording the EUT operating situation during compliance testing and decide the EUT immunity criterion.

13.7. Test Results

Temperature	22°C	Humidity	50%	
Frequency Range (MHz)	Injected Position	Strength	Criterion	Result
0.15 ~ 30	AC Line	3V(rms), Unmodulated	A	PASS
30 ~ 80	AC Line	1V(rms), Unmodulated	A	PASS

14. MAGNETIC FIELD IMMUNITY TEST

14.1 Block Diagram of Test Setup

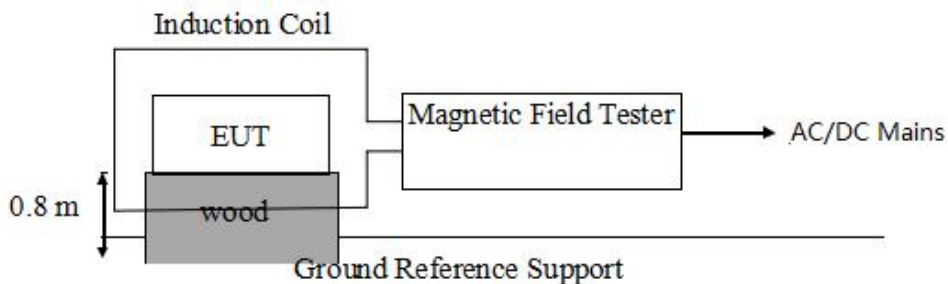

14.2 Test Standard

EN 55035:2017+A11:2020, IEC 61000-4-8:2009
Severity Level 1 at 1A/m

14.3 Severity Levels and Performance Criterion

14.3.1 Severity level

Level	Magnetic Field Strength A/m
1.	1
2.	3
3.	10
4.	30
5.	100
X.	Special

14.3.2 Performance criterion : A

14.4 EUT Configuration on Test

The configuration of EUT are listed in Section 3.2.

14.5 Operating Condition of EUT

14.5.1. Setup the EUT as shown in Section 14.1

14.5.2. Turn on the power of all equipments.

14.5.3. Let the EUT work in test mode (ON) and test it.

14.6 Test Procedure

The EUT shall be subjected to the test magnetic field by using the induction coil of standard dimensions (1m*1m) and shown in Section 14.1. The induction coil shall then be rotated by 90° in order to expose the EUT to the test field with different orientations.

14.7 Test Results

PASS.

15. VOLTAGE DIPS AND INTERRUPTIONS TEST

15.1. Voltage Dips and Interruptions Test Setup

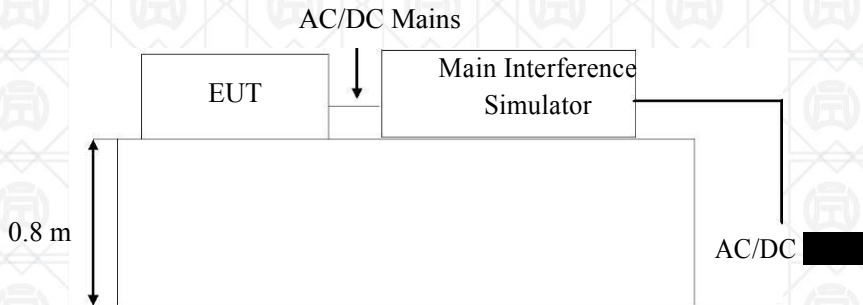

Remark: Combination wave generator and decoupling network are included in test generator.

15.2. Test Standard

EN 55035:2017+A11:2020, IEC 61000-4-11:2004

15.3. Severity Levels and Performance Criterion

15.3.1. Severity level

Test Level %UT	Voltage dip and short interruptions %UT	Duration (in period)	Duration Times
0	100	0.5p	10ms
70	30	25p	500ms
0	100	250p	5000ms

15.3.2. Performance criterion : C & B

15.4. EUT Configuration on Test

The configuration of EUT are listed in Section 3.2.

15.5. Operating Condition of EUT

15.5.1. Setup the EUT as shown in Section 15.1.

15.5.2. Turn on the power of all equipment.

15.5.3. Let the EUT work in test mode (On) and test it.

15.6. Test Procedure

1. Set up the EUT and test generator as shown on Section 15.1.
2. The interruptions is introduced at selected phase angles with specified duration.

3. Record any degradation of performance.

15.7. Test Result

Temperature	22°C		Humidity	50%	
Test Level % U _T	Voltage Dips & Short Interruptions % U _T	Duration (in period)	Phase Angle	Criterion	Result
0	100	0.5P	0°, 90°, 270°	B	PASS
30	70	25P	0°, 90°, 270°	C	PASS
0	100	250P	0°, 90°, 270°	C	PASS

APPENDIX I :Conducted Emission Test data

Operation Mode : Normal operation
 Phase : L (150kHz - 30MHz)

Test Graph

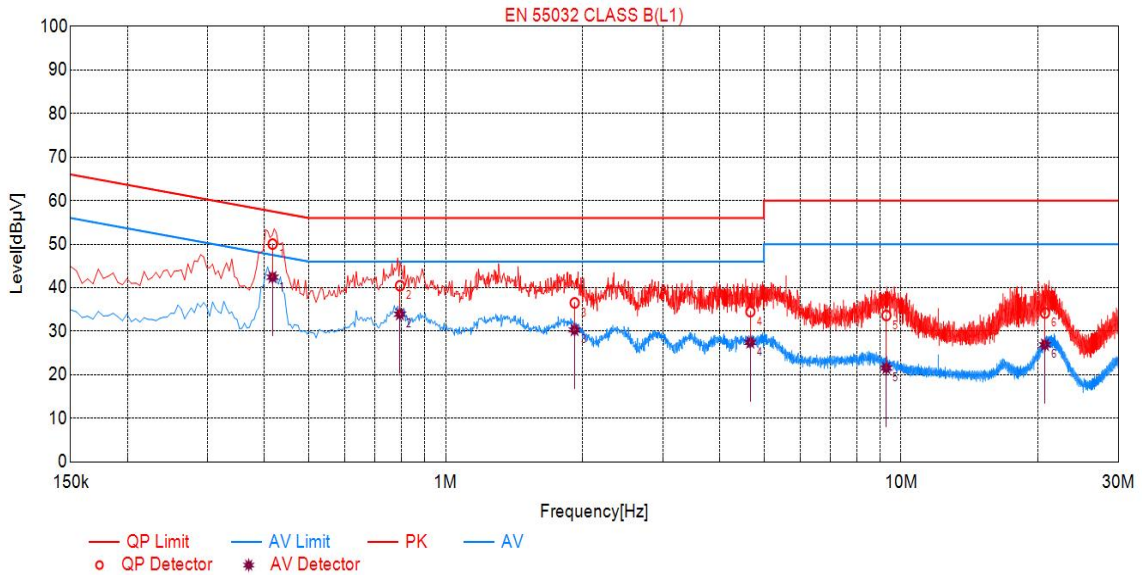

Final Data List								
NO.	Freq. [MHz]	QP Value [dBuV]	QP Limit [dBuV]	QP Margin [dB]	AV Value [dBuV]	AV Limit [dBuV]	AV Margin [dB]	Verdict
1	0.4165	50.02	57.52	7.50	42.41	47.52	5.11	PASS
2	0.7933	40.45	56.00	15.55	33.92	46.00	12.08	PASS
3	1.9195	36.52	56.00	19.48	30.29	46.00	15.71	PASS
4	4.6672	34.51	56.00	21.49	27.44	46.00	18.56	PASS
5	9.2846	33.62	60.00	26.38	21.54	50.00	28.46	PASS
6	20.7119	34.19	60.00	25.81	26.89	50.00	23.11	PASS

Operation Mode : Normal operation
 Phase : N (150kHz - 30MHz)

Test Graph

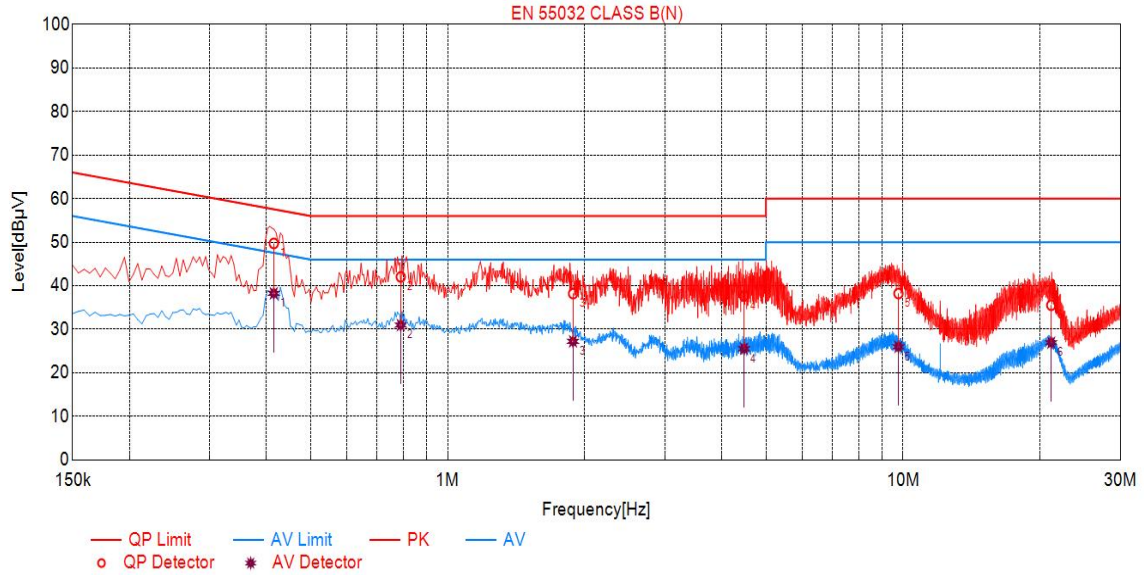

Final Data List								
NO.	Freq. [MHz]	QP Value [dBµV]	QP Limit [dBµV]	QP Margin [dB]	AV Value [dBµV]	AV Limit [dBµV]	AV Margin [dB]	Verdict
1	0.4149	49.72	57.55	7.83	38.24	47.55	9.31	PASS
2	0.7885	42.02	56.00	13.98	30.95	46.00	15.05	PASS
3	1.8846	38.19	56.00	17.81	27.22	46.00	18.78	PASS
4	4.4771	37.63	56.00	18.37	25.52	46.00	20.48	PASS
5	9.7717	38.21	60.00	21.79	25.96	50.00	24.04	PASS
6	21.1626	35.52	60.00	24.48	26.91	50.00	23.09	PASS

APPENDIX II: Radiated Emission Test data

Polarization : Horizontal
 Operation Mode : Normal operation

Test Graph
 74.3 dBuV/m

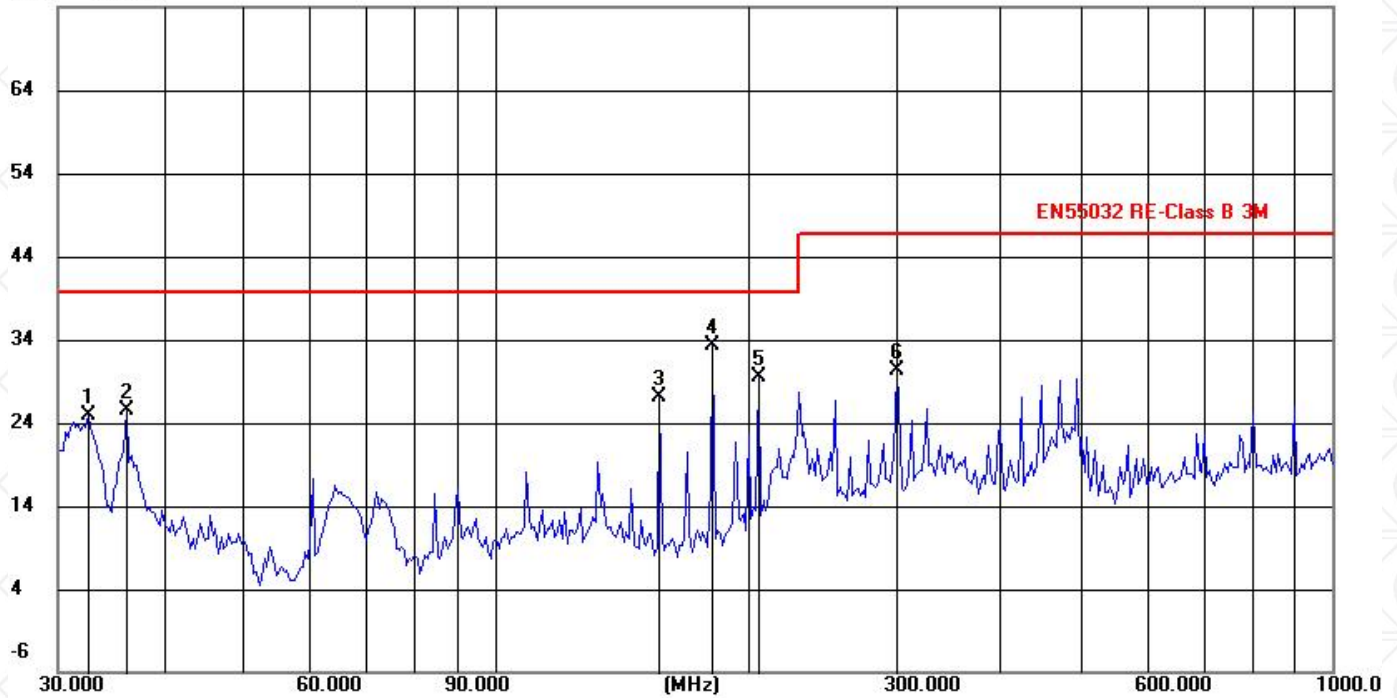

No.	Frequency (MHz)	Reading (dBuV)	Factor (dB/m)	Level (dBuV/m)	Limit (dBuV/m)	Margin (dB)	Det.	Height (cm)	Azimuth (deg)	Remark
1	32.6340	33.32	-8.06	25.26	40.00	-14.74	peak		180	
2	36.2541	35.86	-9.97	25.89	40.00	-14.11	peak		180	
3	157.0074	41.50	-14.11	27.39	40.00	-12.61	peak		180	
4 *	181.9202	48.74	-15.10	33.64	40.00	-6.36	peak		180	
5	206.3976	45.05	-15.18	29.87	40.00	-10.13	peak		180	
6	301.4224	42.44	-11.93	30.51	47.00	-16.49	peak		180	

Polarization : Vertical
 Operation Mode : Normal operation

Test Graph
 74.3 dBuV/m

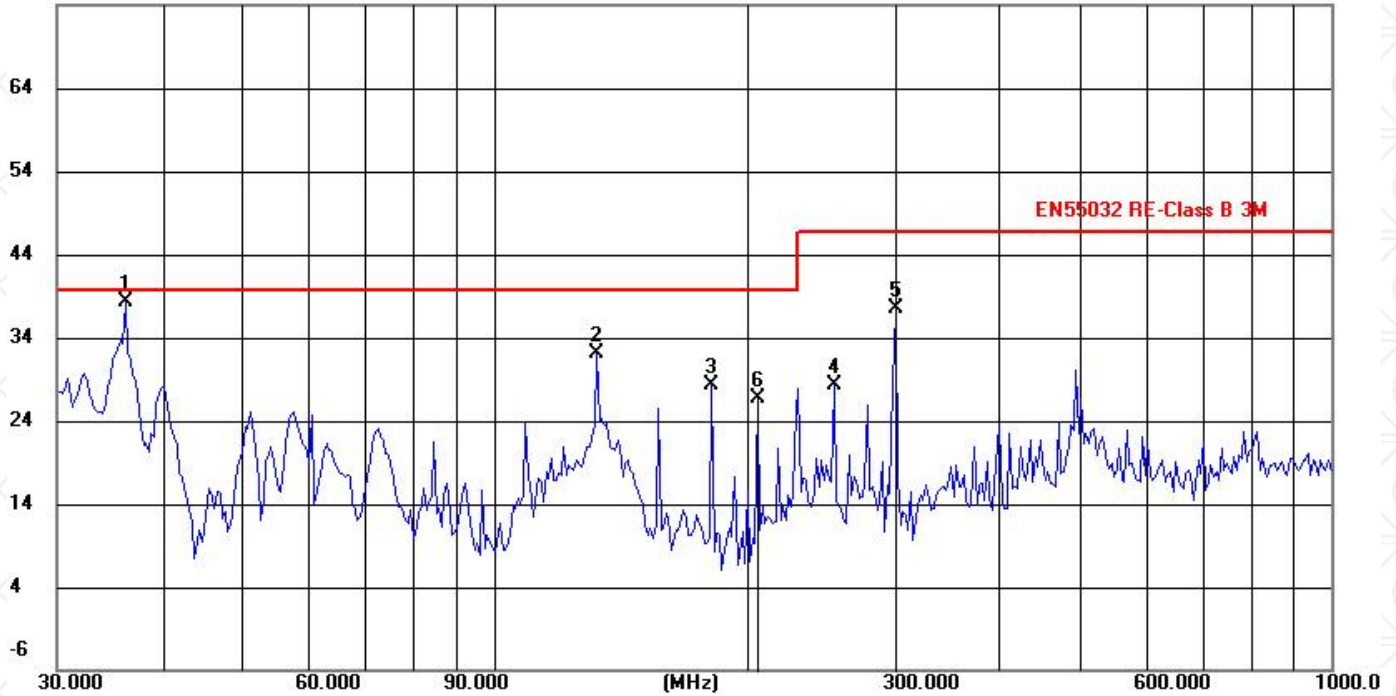

No.	Frequency (MHz)	Reading (dBuV)	Factor (dB/m)	Level (dBuV/m)	Limit (dBuV/m)	Margin (dB)	Det.	Height (cm)	Azimuth (deg)	Remark
1 *	36.2541	48.56	-9.97	38.59	40.00	-1.41	peak		180	
2	132.6850	45.29	-12.84	32.45	40.00	-7.55	peak		180	
3	181.9202	43.80	-15.10	28.70	40.00	-11.30	peak		180	
4	254.7284	41.23	-12.72	28.51	47.00	-18.49	peak		180	
5	301.4224	49.63	-11.93	37.70	47.00	-9.30	peak		180	
6	206.3976	42.22	-15.18	27.04	40.00	-12.96	peak		180	

APPENDIX III: Harmonic Emission Test data

Harmonics Test Report_IEC 61000-3-2 Ed. 5.1 (2020)

Tester	: Tom				
Tested Device:	Video Mixer	Product Type :	mini-pro	Work Mode :	Normal operation
Test Type	: Class A_IEC 61000-3-2 Ed. 5.1 (2020)			Pre-Heat Time :	900 s
Test Date	: 2023-08-29	Start Time :	10:55:00	End Time :	10:57:30
Temperature	: 25.0°C	Humidity :	57.0%	Test Volt. :	230.00V
Comments	:				
Customer	: RGBlink Science & Technology Co.,Ltd	Result	:	Pass	

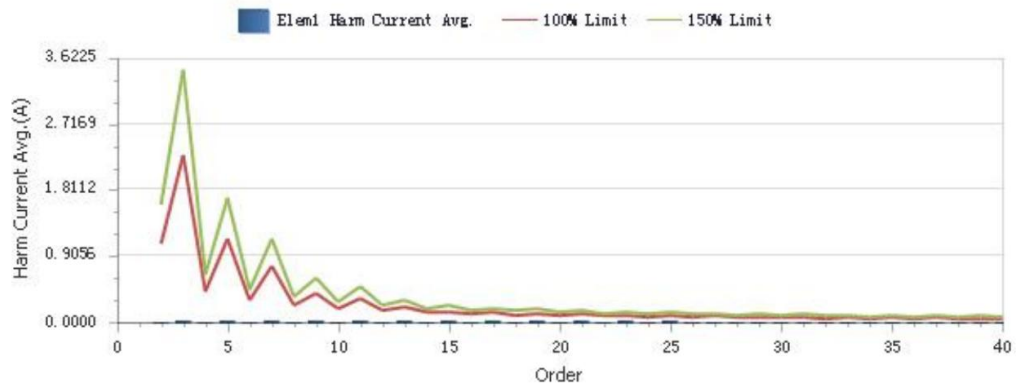
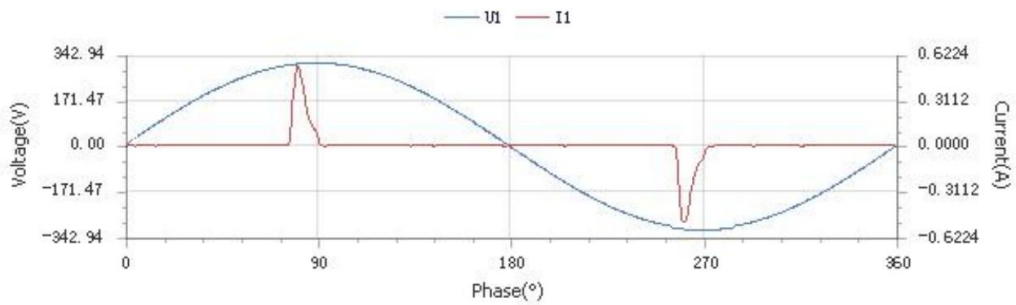

Current Test Record

Tester : Tom
 Tested Device: Video Mixer Product Type : mini-pro Work Mode : Normal operation
 Test Type : Class A_ IEC 61000-3-2 Ed. 5.1 (2020) Pre-Heat Time : 900 s
 Test Date : 2023-08-29 Start Time : 10:55:00 End Time : 10:57:30
 Temperature : 25.0°C Humidity : 57.0% Test Volt. : 230.00V
 Comments :
 Customer : RGBlink Science & Technology Co.,Ltd Result : Pass

Total Current Harmonics and Some Odd Harmonic Parameters

THC(A)	0.0822	THD(%)	274.05	POHC(A)	0.0338	POHC Limit(A)	0.2514
--------	--------	--------	--------	---------	--------	---------------	--------

Maximum Value of Relevant Parameter During Test Period

Urms(V)	220.29	Freq(Hz)	50.000
Irms(A)	0.0894	Ipeak(A)	0.5737
II(A)	0.0304	ICF	6.5049
P(W)	6.6152	λ	0.3376

Determination of Harmonics and Limits

Order(n)	Harmonics Current Avg.(A)	100% Limit(A)	Limit Percent(%)	Harmonics Current Max.(A)	150% Limit(A)	Limit Percent(%)	Result
2	0.0015	1.0800	N/A	0.0017	1.6200	N/A	Pass
3	0.0296	2.3000	1.29	0.0300	3.4500	0.87	Pass
4	0.0015	0.4300	N/A	0.0017	0.6450	N/A	Pass
5	0.0289	1.1400	2.54	0.0293	1.7100	1.71	Pass
6	0.0014	0.3000	N/A	0.0017	0.4500	N/A	Pass
7	0.0279	0.7700	3.62	0.0283	1.1550	2.45	Pass
8	0.0014	0.2300	N/A	0.0017	0.3450	N/A	Pass
9	0.0267	0.4000	6.68	0.0270	0.6000	4.50	Pass
10	0.0014	0.1840	N/A	0.0017	0.2760	N/A	Pass
11	0.0252	0.3300	7.64	0.0255	0.4950	5.15	Pass
12	0.0014	0.1533	N/A	0.0017	0.2300	N/A	Pass
13	0.0235	0.2100	11.19	0.0238	0.3150	7.56	Pass
14	0.0014	0.1314	N/A	0.0017	0.1971	N/A	Pass
15	0.0216	0.1500	14.40	0.0219	0.2250	9.73	Pass
16	0.0014	0.1150	N/A	0.0017	0.1725	N/A	Pass
17	0.0197	0.1324	14.88	0.0199	0.1985	10.03	Pass
18	0.0015	0.1022	N/A	0.0017	0.1533	N/A	Pass
19	0.0178	0.1184	15.03	0.0180	0.1776	10.14	Pass
20	0.0015	0.0920	N/A	0.0018	0.1380	N/A	Pass
21	0.0159	0.1071	14.85	0.0161	0.1607	10.02	Pass
22	0.0015	0.0836	N/A	0.0018	0.1255	N/A	Pass
23	0.0142	0.0978	14.52	0.0143	0.1467	9.75	Pass
24	0.0016	0.0767	N/A	0.0018	0.1150	N/A	Pass
25	0.0125	0.0900	13.89	0.0127	0.1350	9.41	Pass
26	0.0016	0.0708	N/A	0.0019	0.1062	N/A	Pass
27	0.0111	0.0833	13.33	0.0114	0.1250	9.12	Pass
28	0.0016	0.0657	N/A	0.0019	0.0986	N/A	Pass
29	0.0100	0.0776	12.89	0.0102	0.1164	8.76	Pass
30	0.0016	0.0613	N/A	0.0019	0.0920	N/A	Pass
31	0.0090	0.0726	12.40	0.0093	0.1089	8.54	Pass
32	0.0016	0.0575	N/A	0.0019	0.0863	N/A	Pass
33	0.0083	0.0682	12.17	0.0085	0.1023	8.31	Pass
34	0.0016	0.0541	N/A	0.0019	0.0812	N/A	Pass
35	0.0077	0.0643	11.98	0.0080	0.0964	8.30	Pass
36	0.0015	0.0511	N/A	0.0018	0.0767	N/A	Pass
37	0.0072	0.0608	11.84	0.0075	0.0912	8.22	Pass
38	0.0015	0.0484	N/A	0.0018	0.0726	N/A	Pass
39	0.0068	0.0577	11.79	0.0071	0.0865	8.21	Pass
40	0.0014	0.0460	N/A	0.0017	0.0690	N/A	Pass

Voltage Test Record

Tester : Tom
 Tested Device: Video Mixer Product Type : mini-pro Work Mode : Normal operation
 Test Type : Class A_ IEC 61000-3-2 Ed. 5.1 (2020) Pre-Heat Time : 900 s
 Test Date : 2023-08-29 Start Time : 10:55:00 End Time : 10:57:30
 Temperature : 25.0°C Humidity : 57.0% Test Volt. : 230.00V
 Comments :
 Customer : RGBlink Science & Technology Co.,Ltd Result : Pass

Determination of Voltage Relevant Parameter During Test Period

Item	Nominal Value	Tested Value	Error Value	Allowable Error Value	Result
Urms(V)	220.00	220.30	0.30	±2.0%	Pass
Frequency(Hz)	50.000	49.999	0.001	±0.5%	Pass
CFU	1.4100	1.4156	0.0056	±0.01	Pass
Peak-Volt Phase	90.00	90.79	0.79	±3	Pass

Determination of Voltage Harmonics and Limits

Order(n)	Uhdf	Limit(%)	Limit Percent(%)	Result
1	100%	---	---	---
2	0.01%	0.20	5.52%	Pass
3	0.01%	0.90	1.65%	Pass
4	0.00%	0.20	1.32%	Pass
5	0.00%	0.40	0.35%	Pass
6	0.00%	0.20	1.30%	Pass
7	0.00%	0.30	0.53%	Pass
8	0.00%	0.20	1.94%	Pass
9	0.00%	0.20	2.32%	Pass
10	0.01%	0.20	4.54%	Pass
11	0.00%	0.10	1.75%	Pass
12	0.01%	0.10	8.16%	Pass
13	0.00%	0.10	4.07%	Pass
14	0.00%	0.10	4.72%	Pass
15	0.00%	0.10	1.94%	Pass
16	0.00%	0.10	1.72%	Pass
17	0.00%	0.10	0.99%	Pass
18	0.00%	0.10	0.98%	Pass
19	0.00%	0.10	1.17%	Pass
20	0.00%	0.10	0.85%	Pass
21	0.00%	0.10	4.88%	Pass
22	0.00%	0.10	0.93%	Pass
23	0.00%	0.10	4.18%	Pass
24	0.00%	0.10	1.20%	Pass
25	0.00%	0.10	2.45%	Pass
26	0.00%	0.10	1.00%	Pass
27	0.00%	0.10	3.60%	Pass
28	0.00%	0.10	1.05%	Pass
29	0.00%	0.10	1.86%	Pass
30	0.00%	0.10	1.03%	Pass
31	0.00%	0.10	2.43%	Pass
32	0.00%	0.10	1.04%	Pass
33	0.00%	0.10	1.05%	Pass
34	0.00%	0.10	1.28%	Pass
35	0.00%	0.10	1.02%	Pass
36	0.00%	0.10	1.07%	Pass
37	0.00%	0.10	1.36%	Pass
38	0.00%	0.10	1.57%	Pass
39	0.00%	0.10	2.30%	Pass
40	0.00%	0.10	0.89%	Pass

APPENDIX IV: Flicker Test data

Flicker Test Report IEC 61000-3-3 Ed. 3.1 (2017)

Tester : Tom
 Tested Device: Video Mixer Product Type : mini-pro Work Mode : Normal operation
 Test Type : All Parameters
 Test Date : 2023-08-29 Start Time : 10:59:47 End Time : 11:09:47
 Temperature : 25.0°C Humidity : 57.0% Test Volt. : 230.00V
 Comments :
 Customer : RGBlink Science & Technology Co.,Ltd Result : PASS

Pst and Limit

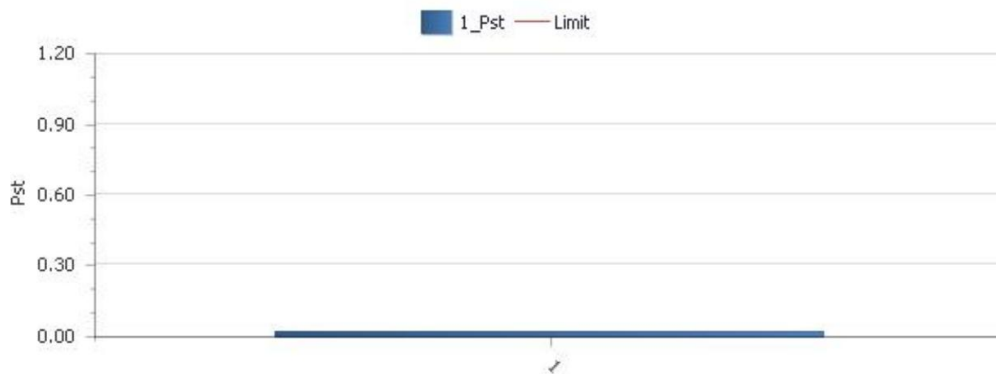

Plt and Limit

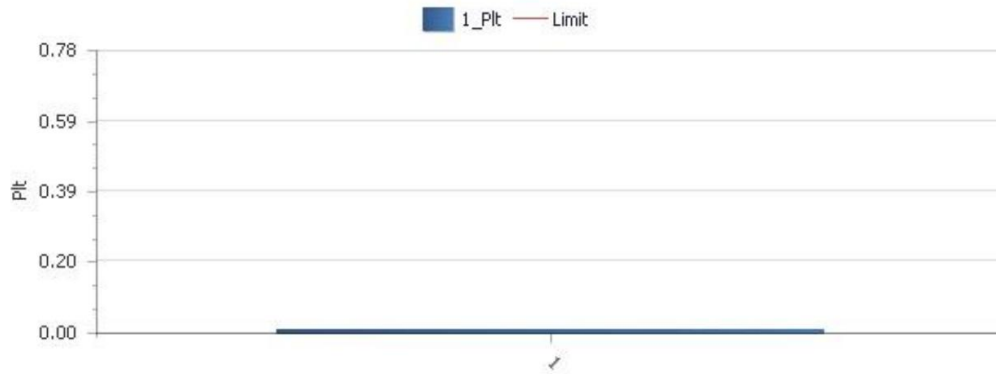

Relevant Parameter and Judgement During Test Period

Vrms at the end of test(V)	230.21			
Error Max(%)		Test Limit(%)		
T-max(ms)	0.00	Test Limit(ms)	500	Pass
dc(%)	0.00	Test Limit(%)	3.30	Pass
dmax(%)	0.00	Test Limit(%)	4.00	Pass
Pst	0.019	Test Limit	1.000	Pass
Plt	0.008	Test Limit	0.650	Pass

Elem1 Test Parameters

Num	dc(%)	dmax(%)	Tmax(ms)	Pst	Plt
1	0.00	0.00	0.00	0.019	0.008

APPENDIX V: EUT and Test Setup Photo



Figure 1: EUT Front-Side



Figure 2: Conducted Emission Test Setup

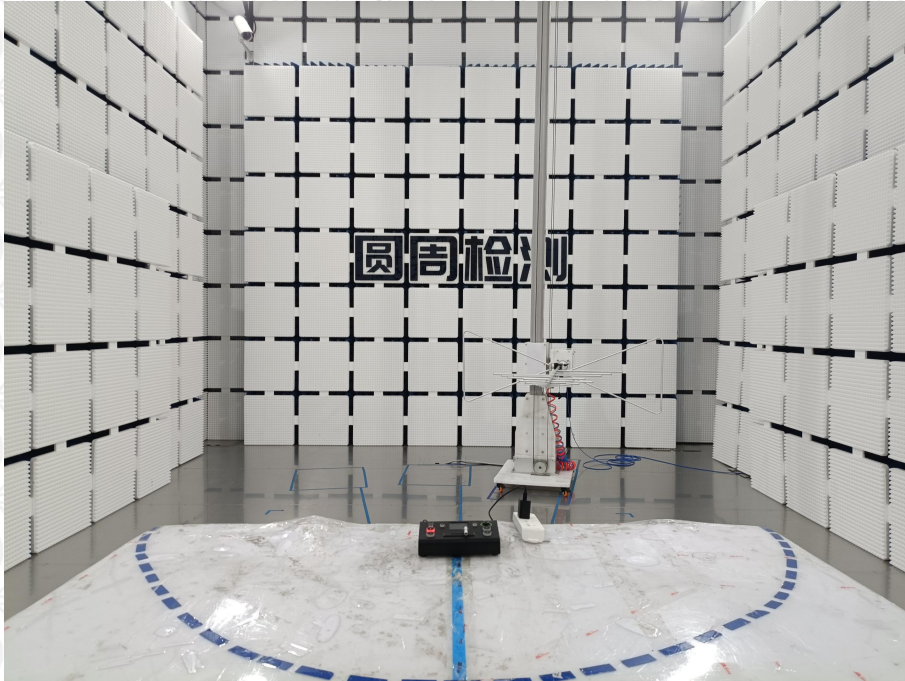

Figure 3: Radiated Emission Test Setup



Figure 4: Electrostatic Discharge Test Setup

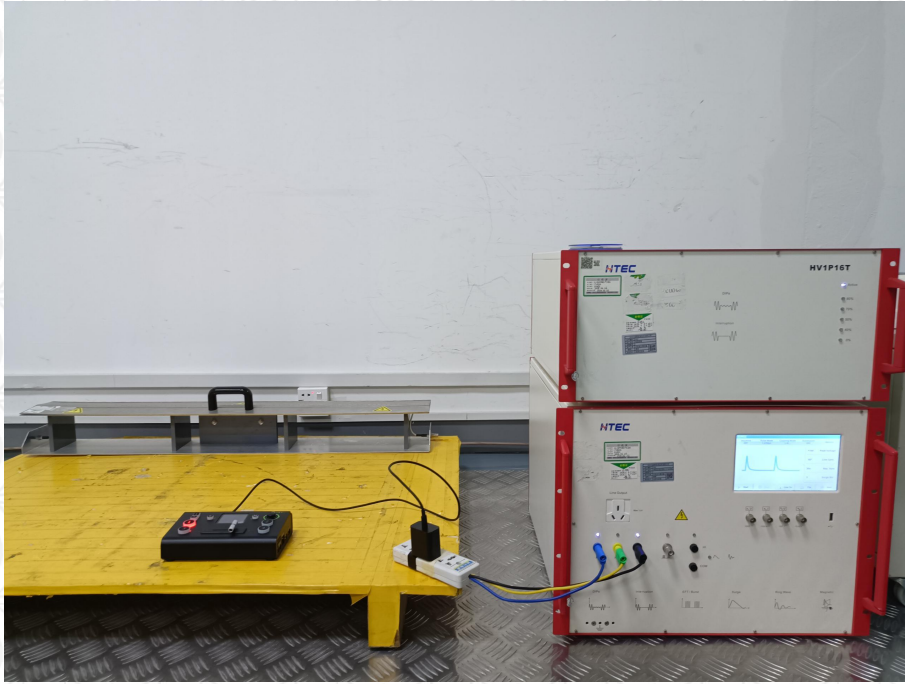

Figure 5: SURGE、DIP&EFT Test Setup

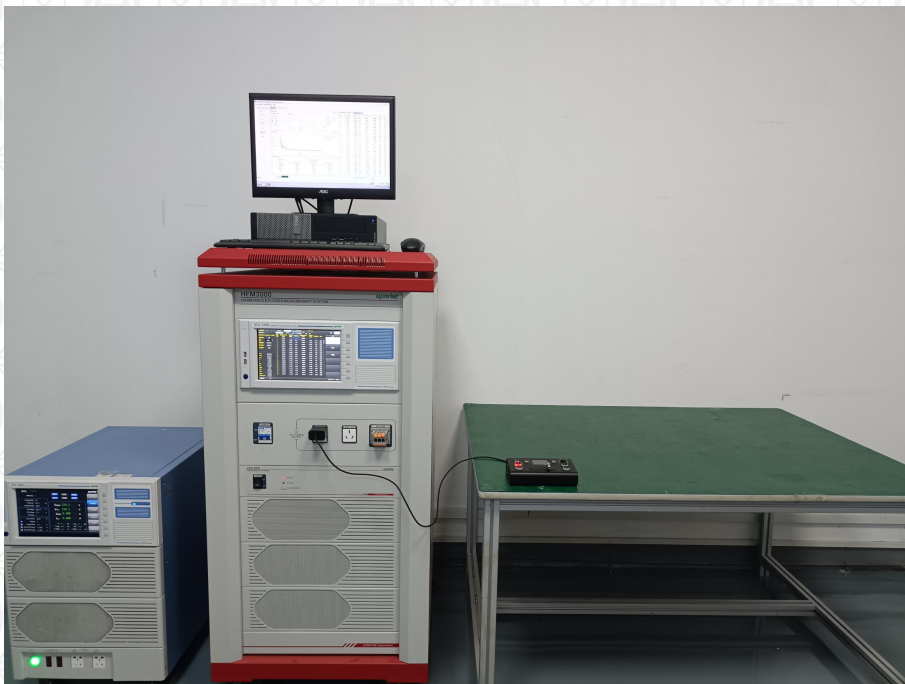

Figure 6: Harmonic & Flicker Test Setup

*** End of Report ***