

- ***2022 CATALOGUE*** 

## WHY RGBLINK

### LEADING INNOVATION

All Research & Development carried out in house.

Creative solutions to real-world problems

Standards based approach

Member of recognised industry groups

World leading high quality, high performance video processing.

### DESIGN & MANUFACTURE

Scalers

Seamless Switches

Matrixes

Video Wall Controllers

Vision Mixers

LED Display Controllers

Signal Converters

### MARKETS

Corporate

Broadcast

Live Events

House of Worship

Education

Government

Health Care

Retail & Themed Entertainment

### GLOBAL PRESENCE

Growing world-wide distribution network

See RGBlink at all major industry trade events.

Products are been widely adoption in mission critical applications around the world.





## STREAMING

**31** CLOUD / DECODER

**01** CAPTURE

**35** ASK Series  
collaboration solutions

**17** SWITCHER

**25** ENCODER

## PRO AV

**103** FLEX Series  
Mixed Signal Matrix

**45** D Series  
Presentation Processors

**119** Q Series  
FLEX multi-signal matrix

**59** X Series  
Universal Processors

**89** M Series  
Mixing & Scaling

**141** Subito Series  
LED Control Solutions

**149** UMS Series  
Media Solutions

**127** 1 Series  
Switcher/Scalers

**135** T Series  
Control Consoles

**173** Accessories

**179** Software

**155** RMS Series  
Monitoring Solutions

**159** MSP Series  
Video Tools / Extenders  
Signal Convertors  
Signal Distributors

**183** Reference

**199** Contact

# STREAMING



# CAPTURE



## PTZ Camera

RGB12X-PTZ-WH | RGB20X-PTZ-WH





PTZ camera offers perfect functions, superior performance and rich interfaces. The features include advanced ISP processing algorithms to provide vivid images with a strong sense of depth, high resolution and fantastic color rendition. It supports H.265/H.264 encoding which makes motion video fluent and clear even with less than ideal bandwidth conditions



## Professional PTZ Camera

Whether outputting to HDMI, SDI or IP, RGBlink PTZ cameras provide a host of onboard features and functions. Advanced ISP image processing and algorithms enhance image performance from the sensor.

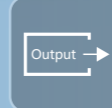
Full 340 degree horizontal and 120 degree vertical range along with up to wide 72.5 degree viewing angle are provided, making RGBlink cameras suitable for demanding applications whether short throw or long.

-   
 12X/20X Optical
-   
 Multi-protocol API/VISCA
-   
 pan-and-tilt rotation
-   
 HDMI/RS23 Audio/IP/3G-SDI
-   
 1080p60 Full HD
-   
 1-year Warranty 3-years of paid maintenance

## Precise Head Control

With built-in high precision motor drive control, the camera can be re-positioned in under a second by 60 degrees and a zoom speed of 0.1 degree. Whether large movement or small, multi-speed movement is not only smooth and accurate, but super quiet. Automatic focussing powered with advanced algorithms enhances overall performance aiding ease of operation.



## Multi-Scene Preset

Create and store up to 255 presets with position, zoom and focus via the web interface. Assign presets to buttons for instant recall.



Up to 255 preset positions

## 12X/20X Optical Zoom

With a choice of two models, RGBlink PTZ cameras offer embedded 2D & 3D noise reduction and ISP image processing technology. The result is clear, vivid and balance video regardless of zoom angle.



## Web Preview

Preview video and control camera via the web-browser based interface simply by connecting on a LAN. Use any video output for monitoring.

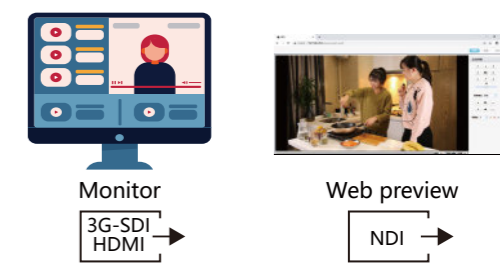

## Full Interface Multi-Protocol

RGBlink PTZ cameras offer wide compatibility and interconnectivity in support of the broad range of application possibilities. Video connections are provided for SDI and HDMI as well as for IP based protocols. Control protocols include RTSP, VISCA and PELCO.

### STREAMING

- CAPTURE
- SWITCHER
- ENCODER
- CLOUD/DECODER
- ASK Series Collaboration solutions

### PRO AV

- D Series Digital Processors
- X Series Universal Processors
- M Series Mixing & Scaling
- FLEX Series Mixed Signal Matrix
- Q Series FLEX multi-signal matrix
- 1 Series Switcher/Scalers
- T Series Control Consoles
- Subito Series LED Control Solutions
- UMS Series Media Solutions
- RMS Series Monitoring Solutions
- MSP Series Video Tools/Extenders Signal Convertors Signal Distributors
- Accessories
- Software
- Reference
- Contact



## **PTZ Camera with NDI** RGB12X-NDI-WH | RGB20X-NDI-WH

NDI camera offers perfect functions, superior performance and rich interfaces. The features include advanced ISP processing algorithms to provide vivid images with a strong sense of depth, high resolution and fantastic color rendition. It supports H.265/H.264 encoding which makes motion video fluent and clear even with less than ideal bandwidth conditions



## Professional NDI Camera

Whether outputting to HDMI, SDI or NDI, RGBlink PTZ cameras provide a host of onboard features and functions. Advanced ISP image processing and algorithms enhance image performance from the sensor, encoding for smooth and stabilised video regardless of bandwidth selected.

Full 340 degree horizontal and 120 degree vertical range along with up to wide 72.5 degree viewing angle are provided, making RGBlink cameras suitable for demanding applications whether short throw or long.

- 12X/20X Optical
- Multi-protocol API/VISCA
- pan-and-tilt rotation
- HDMI/RS23 Audio/IP/3G-SDI
- 1080p60 Full HD
- 1-year Warranty 3-years of paid maintenance

## Precise Head Control

With built-in high precision motor drive control, the camera can be re-positioned in under a second by 60 degrees and a zoom speed of 0.1 degree. Whether large movement or small, multi-speed movement is not only smooth and accurate, but super quiet. Automatic focussing powered with advanced algorithms enhances overall performance aiding ease of operation.



## NDI Video Output

Video over IP via NDI is built right into these cameras, enabling quick and ease integration with professional broadcast suites as well as popular NDI enabled platforms such as Zoom.



## 12X/20X Optical Zoom

With a choice of two models, RGBlink PTZ cameras offer embedded 2D & 3D noise reduction and ISP image processing technology. The result is clear, vivid and balance video regardless of zoom angle.



## Multi-Scene Preset

Create and store up to 255 presets with position, zoom and focus via the web interface. Assign presets to buttons for instant recall.



Up to 255 preset positions

## Web Preview

Preview video and control camera via the web-browser based interface simply by connecting on a LAN. Use any video output for monitoring.

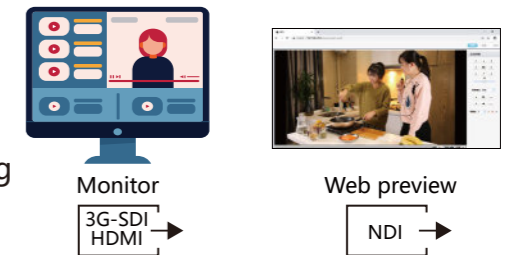

## High Sensitivity

Capture video even in low light – from as little as 0.5 Lux. The cameras sensor adapts and optimises across the full range of light and dark environments.

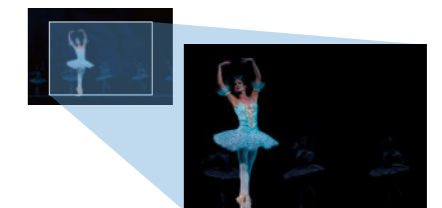

## Full Interface Multi-Protocol

RGBlink PTZ cameras offer wide compatibility and interconnectivity in support of the broad range of application possibilities. Video connections are provided for SDI and HDMI as well as for IP based protocols. Control protocols include RTSP, VISCA and PELCO.

### STREAMING

- CAPTURE
- SWITCHER
- ENCODER
- CLOUD/DECODER
- ASK Series Collaboration solutions

### PRO AV

- D Series Digital Processors
- X Series Universal Processors
- M Series Mixing & Scaling
- FLEX Series Mixed Signal Matrix
- Q Series FLEX multi-signal matrix
- 1 Series Switcher/Scalers
- T Series Control Consoles
- Subito Series LED Control Solutions
- UMS Series Media Solutions
- RMS Series Monitoring Solutions
- MSP Series Video Tools/Extenders Signal Convertors Signal Distributors
- Accessories
- Software
- Reference
- Contact



## PTZ Camera Controller RGBCTL-PTZ-BK

Four control modes: Two IP control modes (IP VISCA & ONVIF); Two analog control modes (RS422 & RS232) Three Control Protocols: VISCA, ONVIF and PELCO

## PTZ Controller

Enabling fast and accurate control of PTZ cameras, the RGBlink PTZ controller brings together control of multiple cameras into a single convenient console interface.

Control up to 255 PTZ cameras with both LAN port and serial port connectivity available. Joystick control along with intuitive one touch button controls deliver real-time control to cameras, complemented with by an on-board LCD display.



## 4-dimensional Joystick

Make precise adjustments to camera attributes including movement, zoom, focus and selection with the multi-function broadcast style joystick control.



## Fingertip Control

Buttons and rotary controls are arranged for quick access, arranged intuitively and conveniently. Set camera features such as speed, red and blue gain, focus, aperture, white balance, camera switching and other camera parameters along with accessing and setting presets, and more.

## LCD Display

See and monitor status and configuration from the on-board LCD display.



## Presets

Quickly capture settings as presets and views. Store up to 255 presets and recall simply via quick-touch keys.

## Control for Serial Cameras

The controller offers RS232/RS422 ports allowing connection of up to 7 cameras via serial supporting VISCA/Pelco-D/P protocols and control for those remote cameras up to 1200m.



## Power from the IP Network

Connect the PTZ controller anywhere on the IP network where power-over-ethernet (PoE) is available, to optionally power the console from the network without a separate power supply.



## Custom Operations

Configure customer functions including VISCA commands.

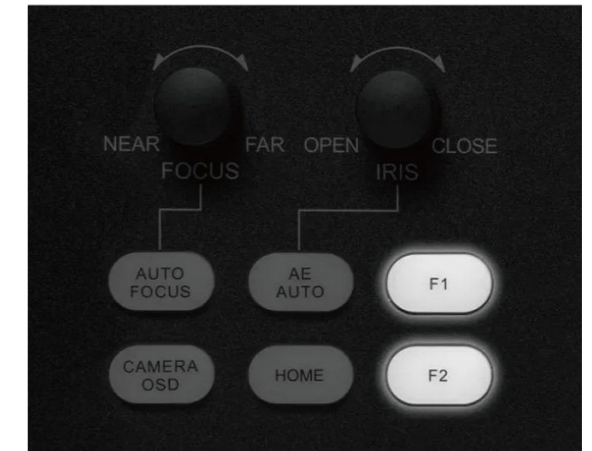

## Connect More PTZ Cameras

Supporting VISCA and ONVIF protocols, connect up to 255 IP cameras to the PTZ controller.

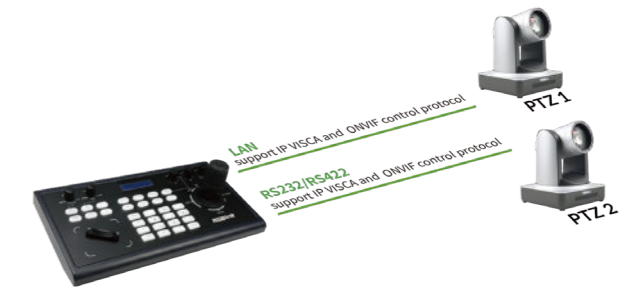

## STREAMING

- CAPTURE
- SWITCHER
- ENCODER
- CLOUD/DECODER
- ASK Series Collaboration solutions

## PRO AV

- D Series Digital Processors
- X Series Universal Processors
- M Series Mixing & Scaling
- FLEX Series Mixed Signal Matrix
- Q Series FLEX multi-signal matrix
- 1 Series Switcher/Scalers
- T Series Control Consoles
- Subito Series LED Control Solutions
- UMS Series Media Solutions
- RMS Series Monitoring Solutions
- MSP Series Video Tools/Extenders Signal Convertors Signal Distributors
- Accessories
- Software
- Reference
- Contact



## PTZ AI Tracking Camera



RGB12X-HAI-WH/RGB20X-HAI-WH



RGB12X-SAI-WH/RGB20X-SAI-WH



RGB20X-PAI-GY



RGB20X-NAI-GY

### Key Features

- Intelligent and smooth teaching tracking
- Low noise and high SNR
- Multiple video compression formats
- Multiple control/network protocols
- Dual-stream output
- Support PoE

## USB PTZ Camera



RGB10X-USB-BK USB PTZ Camera  
with 10X Optical Zoom



RGB20X-USB-WH USB 3.0  
PTZ Camera with 20X Optical Zoom

### Key Features

- 70 degree wide-angle lens
- Auto-focus technology
- Low noise and high SNR
- Up to 255 presets
- Pan and tilt control
- Wide application
- Low-power sleep function

## Ultra HD PTZ Camera 4K



RGB12X-UHD-WH 4K PTZ Camera

## Ultra HD NDI Camera 4K



RGB12X-UNDI-WH 4K NDI Camera

### Key Features

- 4K Ultra HD Image, with resolution up to 4K@60fps
- 12x optical zoom lens, with 80.4° FOV without distortion
- Fast, accurate and stable auto focus
- Low Noise and High SNR
- 4K output through LAN, HDMI and USB 3.0
- Multiple Audio/Video Compression Standard

- Multiple Control port and control protocol
- Multiple Network Protocol include RTMP,RTP,NDI,VISCA

## PTZ POE



RGB20X-POE-WH 20X  
PTZ Camera(PoE)

- Low-power Sleep Function



RGB20X-POE-WH 20X  
PTZ Camera(PoE)

- Support PoE(IEEE 802.3af 48V)

### Key Features

- High speed optical zoom
- High performance in low light scenarios with Wide Dynamic Range
- Full 1920×1080p HD Resolutions up to 60 frames per second
- H.265/H.264 Dual Stream Output Adapted to Different Network Environments
- Pan and Tilt Control
- Wide Application

## STREAMING

CAPTURE

SWITCHER

ENCODER

CLOUD/DECODER

ASK Series  
Collaboration solutions

## PRO AV

D Series  
Digital Processors

X Series  
Universal Processors

M Series  
Mixing & Scaling

FLEX Series  
Mixed Signal Matrix

Q Series  
FLEX multi-signal matrix

1 Series  
Switcher/Scalers

T Series  
Control Consoles

Subito Series  
LED Control Solutions

UMS Series  
Media Solutions

RMS Series  
Monitoring Solutions

MSP Series  
Video Tools/Extenders  
Signal Convertors  
Signal Distributors

Accessories

Software

Reference

Contact

## NDI(PoE) Camera



**RGB20X-PNDI-WH 20X  
NDI Camera**



**RGB30X-PNDI-WH 30X  
NDI Camera**

### Key Features

- High speed optical zoom
- High performance in low light scenarios with Wide Dynamic Range
- Full 1920×1080p HD Resolutions up to 60 frames per second
- 2D & 3D low noise CMOS
- PTZ control via serial, IP or NDI
- H.264, H.265 & MJPEG Streaming
- Stream simultaneously to up to three protocols
- Support PoE(IEEE 802.3af 48V)

## EPTZ Educational Tracking Camera



**RGB3X-EPTZ-BK  
Educational Tracking Camera**

### Key Features

- Intelligent teaching tracking,multiple tracking modes
- Wide dynamic exposure
- Strong anti-interference
- Wide angle without distortion
- Low noise and high SNR
- Multistream output
- Support PoE

## AV Conference Integrated Solution

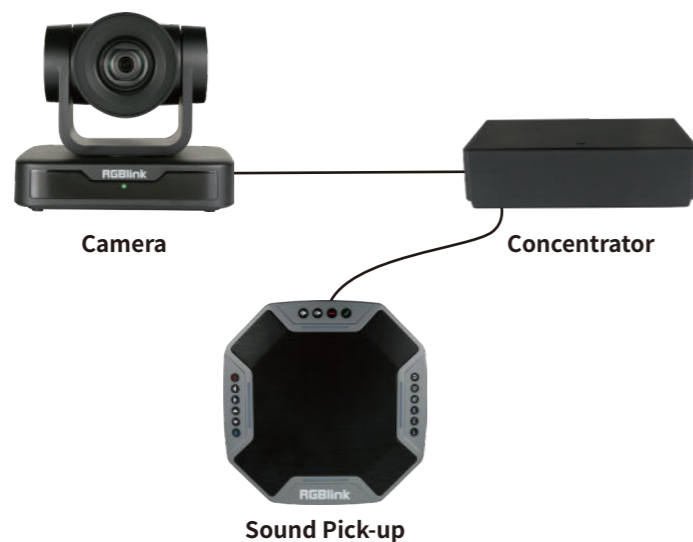

**RGB10X-MEET-BK AV Conference Integrated Solution**

### Key Features

- Superb High - definition image Camera,resolution is up to 1920x1080
- Low noise and high SNR
- Leading auto focus technology
- Support MJPG /H.265 /H.264 video compression
- Sound pick - up support bluetooth hands - free call
- 4 built - in microphone with a single directivity and a wide frequency range
- Built - in IR receiver
- Multiple function keys on front panel
- Encoder supports USB plug and play
- Support multiple web conference software

### STREAMING

CAPTURE

SWITCHER

ENCODER

CLOUD/DECODER

ASK Series  
Collaboration solutions

### PRO AV

D Series  
Digital Processors

X Series  
Universal Processors

M Series  
Mixing & Scaling

FLEX Series  
Mixed Signal Matrix

Q Series  
FLEX multi-signal matrix

1 Series  
Switcher/Scalers

T Series  
Control Consoles

Subito Series  
LED Control Solutions

UMS Series  
Media Solutions

RMS Series  
Monitoring Solutions

MSP Series  
Video Tools/Extenders  
Signal Convertors  
Signal Distributors

Accessories

Software

Reference

Contact

# SWITCHER



## streaming switcher

Mini makes the sophisticated simple. Seamlessly switch between any of up to four inputs and output to both HDMI and USB3.0.

Ideal for streaming applications whether personal or corporate, mini inputs allow different resolutions video sources to be scaled to a common output format.

On board features include PIP, transitions and audio controls. The only compact switcher with built in LCD video preview, mini is truly compact and easy to use.



- Seamless switching between inputs
- Create effect with transitions when switching between sources
- Insert audio via mini Jack or use HDMI embedded audio
- Switch between sources with T-bar or direct touch
- Remote control with Apps connected via LAN
- Add sophistication with Picture-in-Picture (PIP) presets
- Preview all video inputs simultaneous
- Stream direct to popular platforms via USB 3,0
- De-embed and extract audio via mini Jack
- On board TFT display with multi-View to preview all sources
- Advanced features for PTZ camera, audio control and more



### Scale Convert Present

Each HDMI input is resolution independent and is automatically cross converted – scaled – to the set output resolution providing seamless glitch free video switching for consistent presentation.

### Preview Built-in

The only streaming switcher in its class with an integrated LCD display and onboard video preview.

### Connect & Control

Switch between any connected video source simply by tapping on the source button in Fast mode or via the T-Bar directly from the front panel. Connect via LAN to one of the mini apps for remote functionality - CUT, set fade times or transitions from anywhere.



### Stream & Capture

Connect mini via USB3.0 to an internet connected laptop to be a video and audio streaming device to virtually any platform. Capture and more via OBS.

### Selectable Multi-View

Output either the program (PGM) or a Multiview – either being selectable on both HDMI and USB3.0 outputs for maximum flexibility.

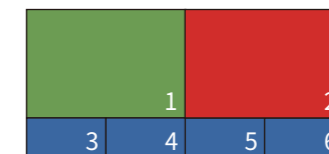

### Audio Controls

Select audio from an embedded or insert line source to be embedded with the video at output. Extract audio via the dedicated

### Transition Effects

Transition between PST & PGM with cut, fade or transition via the T-bar or single touch controls.

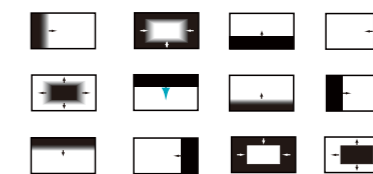

### PIP

Add a Picture-in-Picture video as an overlay in one of nine PIP and PBP preset positions. Whether for closeups or companion shots, PIP allows for two videos to be output at the same time.

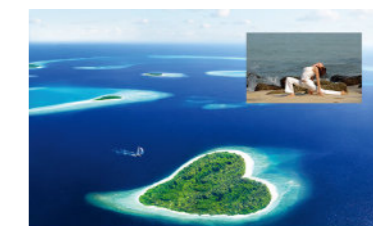

### Stream your feed

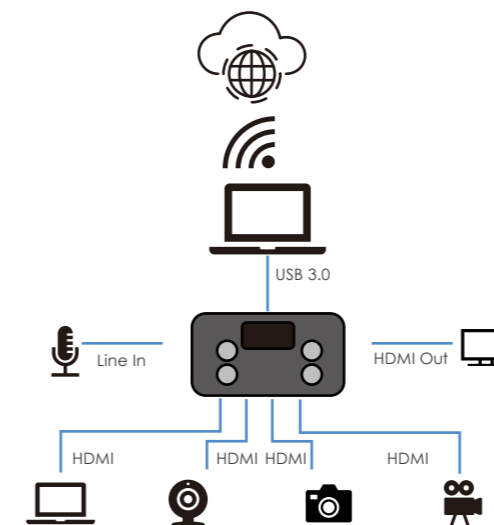

- STREAMING
- CAPTURE
- SWITCHER
- ENCODER
- CLOUD/DECODER
- ASK Series Collaboration solutions
- PRO AV
- D Series Digital Processors
- X Series Universal Processors
- M Series Mixing & Scaling
- FLEX Series Mixed Signal Matrix
- Q Series FLEX multi-signal matrix
- 1 Series Switcher/Scalers
- T Series Control Consoles
- Subito Series LED Control Solutions
- UMS Series Media Solutions
- RMS Series Monitoring Solutions
- MSP Series Video Tools/Extenders Signal Convertors Signal Distributors
- Accessories
- Software
- Reference
- Contact













### streaming switcher

Mini-pro continue to support Windows and MAC desktop operating systems and iOS and Android mobile platform.

In terms of user operations, mini-pro upgrade S key (shortcuts) user experience, by pressing the user scene setting, mini-pro can realize multi-user fast scene and mode switching. Synchronize multiple controls, Small and easy to use, Help you achieve more diversified scene display applications.

# mini pro

-  Mini Switchr, easy to carry
-  The five-way joystick more quickly to adjust the PTZ control, one channel for
-  HDMI 2.0 input and three channels for HDMI 1.3 input
-  Support PC and mobile phone APP
-  control HDMI output and USB3.0 streaming interface switching from optional 6 screen PVW and PGM
-  PIP,PBP and custom layout function supported
-  2-inch TFT touch screen for icon touch screen control and the input signal monitoring
- MIX**  T-Bar switching supports up to 14 kinds of switching special effects
-  USB3.0 direct streaming and mobile phone streaming platform supported
-  Chroma Key chroma matting supported
-  HDMI embedded audio and external audio mixing, audio delay adjustment supported



### Scale Convert Present

Each HDMI input is resolution independent and is automatically cross converted – scaled – to the set output resolution providing seamless glitch free video switching for consistent presentation.

### Preview Built-in

The only streaming switcher in its class with an integrated LCD display and onboard video preview.

### Connect & Control

Switch between any connected video source simply by tapping on the source button in Fast mode or via the T-Bar directly from the front panel. Connect via LAN to one of the mini apps for remote functionality - CUT, set fade times or transitions from anywhere.

### Live broadcast

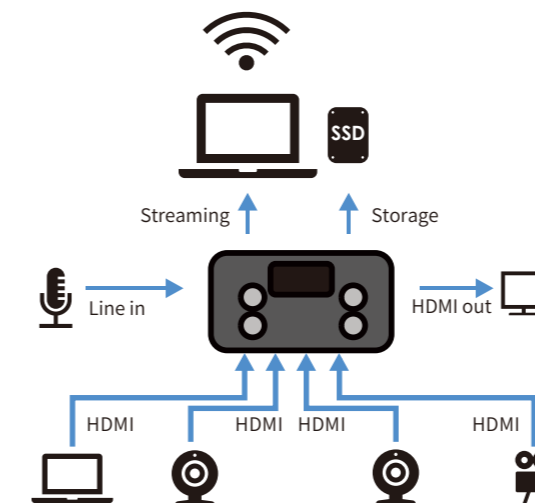

### Stream & Capture

Connect mini via USB3.0 to an internet connected laptop to be a video and audio streaming device to virtually any platform. Capture and more via OBS.

### Synchronise with Audio

Utilise embedded or external audio and extract to audio mixers or other devices for video and audio synchronisation.

### PIP

Add a Picture-in-Picture video as an overlay in one of nine PIP and PBP preset positions. Whether for closeups or companion shots, PIP allows for two videos to be output at the same time.

### PTZ Camera Controls

Connect VISCA/PELCO cameras to mini+ to control pan., tilt, zoom and focus. Store settings as Views directly on mini+ for on demand recall



### Five-way joystick PTZ control

The five-way joystick can control the PTZ camera very flexibly, and with the input switch, you can switch the fast control of 4 PTZ cameras

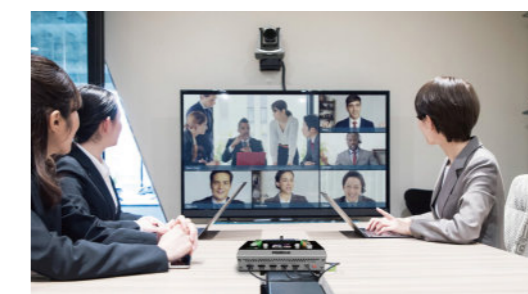

## STREAMING

- CAPTURE
- SWITCHER**
- ENCODER
- CLOUD/DECODER
- ASK Series Collaboration solutions

## PRO AV

- D Series Digital Processors
- X Series Universal Processors
- M Series Mixing & Scaling
- FLEX Series Mixed Signal Matrix
- Q Series FLEX multi-signal matrix
- 1 Series Switcher/Scalers
- T Series Control Consoles
- Subito Series LED Control Solutions
- UMS Series Media Solutions
- RMS Series Monitoring Solutions
- MSP Series Video Tools/Extenders Signal Convertors Signal Distributors

- Accessories
- Software
- Reference
- Contact

# ENCODER



TAO 1pro is a Broadcasting streaming decoder with a 5.5 inch FHD preview display, but also a 4 channels seamless video switcher for 2 USB 3.0 and 2 HDMI 1.3 inputs, and supports streaming directly by ethernet output which is ready to connect to external cloud based router and streaming from Anywhere to Everywhere.

TAO 1pro is compatible with standard USB 2.0 and USB 3.0 cameras by UVC protocol, and brings itself as a much affordable and user friendly streaming tools for anybody, the talents who is willing to be Anchor Online.

TAO 1pro is also with touch panel for finger configuration, and with optional 2 chargable battery extending its capacity for outdoor application.

# TAO 1 pro

Talent Anchor Online

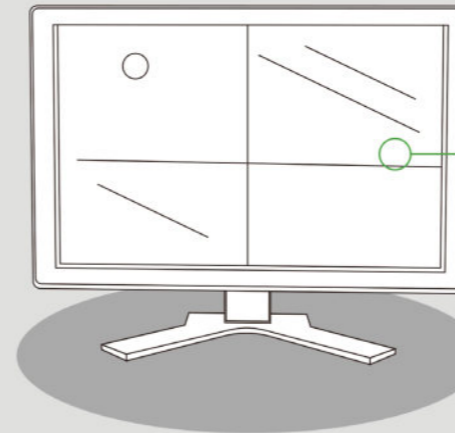

1 Multiple USB and HDMI sources supported, local preview and extended preview available

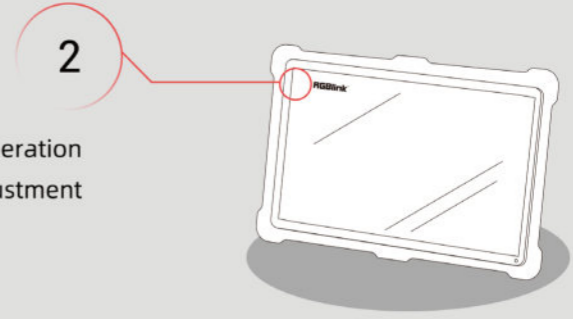

2 HD touch-screen operation easy image/color adjustment

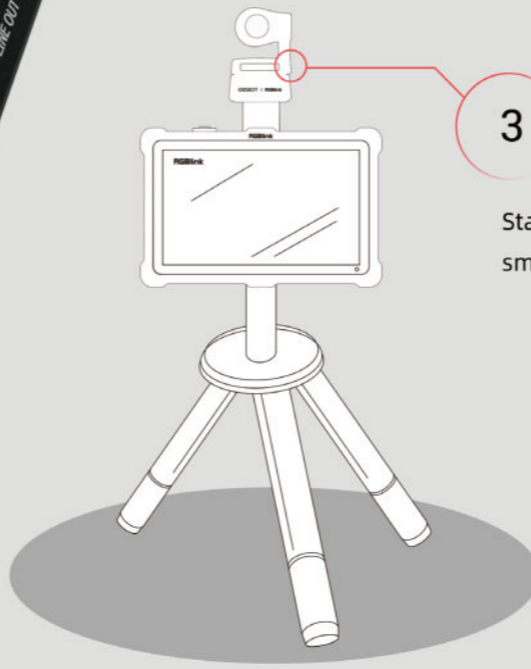



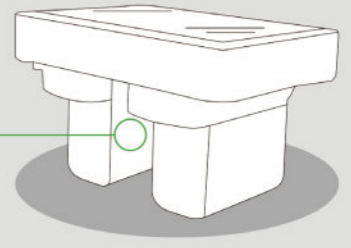







3 Standard USB2.0/3.0, HDMI1.3 devices such as cameras, smart phone, tablet supported, stream anytime you like



4 Dual batteries for backup Endurance power supply

## Key Features

-  · 5.5-inch touchscreen operation
-  · Fast image processing
-  · video monitoring
-  · Dual battery Options
-  · Recording via USB 2.0 port
-  · Multistream up to 4 Live Streaming platform Simultaneously
-  · USB and HDMI signal multicasting
-  · Bluetooth 5.0
-  · Extending Monitor
-  · NDI5.0 Encoder

- STREAMING**
- CAPTURE
- SWITCHER
- **ENCODER**
- CLOUD/DECODER
- ASK Series Collaboration solutions
- PRO AV**
- D Series Digital Processors
- X Series Universal Processors
- M Series Mixing & Scaling
- FLEX Series Mixed Signal Matrix
- Q Series FLEX multi-signal matrix
- 1 Series Switcher/Scalers
- T Series Control Consoles
- Subito Series LED Control Solutions
- UMS Series Media Solutions
- RMS Series Monitoring Solutions
- MSP Series Video Tools/Extenders Signal Convertors Signal Distributors
- Accessories
- Software
- Reference
- Contact

### Scene 1: Seamless switching between USB and HDMI inputs



### Scene 2: Seamless switching between different USB inputs



### Scene 4: Input preview and extending monitor (90° supported)



### Scene 3: Ready for Bluetooth remote control



### Scene 5: Outdoor wireless streaming



- STREAMING**
- CAPTURE
- SWITCHER
- **ENCODER**
- CLOUD/DECODER
- ASK Series Collaboration solutions
- PRO AV**
- D Series Digital Processors
- X Series Universal Processors
- M Series Mixing & Scaling
- FLEX Series Mixed Signal Matrix
- Q Series FLEX multi-signal matrix
- 1 Series Switcher/Scalers
- T Series Control Consoles
- Subito Series LED Control Solutions
- UMS Series Media Solutions
- RMS Series Monitoring Solutions
- MSP Series Video Tools/Extenders Signal Converters Signal Distributors
- Accessories
- Software
- Reference
- Contact



## UVC-HDMI capture converter

TAO 1tiny is the essential accessory for compact webcam and ePTZ camera users, enabling those cameras to become HDMI native devices connectable almost anywhere. This tiny inline convertor- measuring at just 9x5x3cm, provides HDMI connectivity for cameras and similar USB-C UVC capture devices, supporting popular VESA standard resolutions up to 4K Video transcoded to HDMI is uncompressed with full fidelity maintained for superior visual performance.

## The ideal companion for USB cameras

Support for 4K USB-C video devices  
 Connect high quality USB Cameras  
 Output to any HDMI 2.0 display up to 4K@60  
 Lossless high definition video adapter



## Empowering push streaming switchers

Empowering push streaming switchers  
 Transform streaming switchers into live presentation mixers, taking USB 3.0 streams to HDMI screens, projectors and displays.

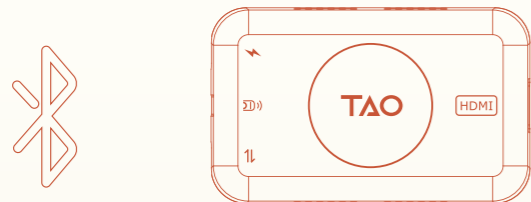

## Enabling remote camera controls

TAO 1tiny supports connection of USB control devices such as Bluetooth Receivers, allowing a connected webcam to be controlled without the need for web or pc software.

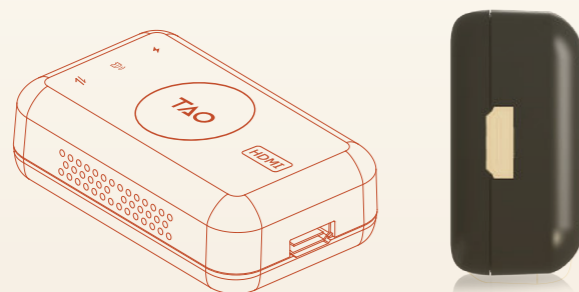

## Efficient low-power by design

Power TAO 1tiny and UVC webcam conveniently with common USB-C hubs and power banks.

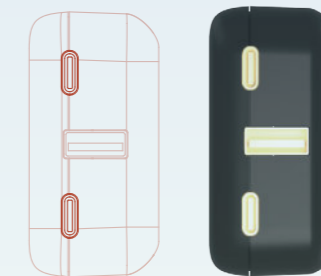

## Key Features

- Bonding Network Router
- 5\*USB port for TD-LTE standard Dongle
- Bonding up to 5 Dongle and 1 LAN together
- WAN external broadband bonding
- 2.4GHz+5.8GHz dual-band wifi
- wifi hotspot sharing
- Real-time status on LCD screen
- Optional built-in lithium battery with higher capacity
- 1/4 screw hole for rack mounting

### STREAMING

- CAPTURE
- SWITCHER
- ENCODER
- CLOUD/DECODER
- ASK Series Collaboration solutions

### PRO AV

- D Series Digital Processors
- X Series Universal Processors
- M Series Mixing & Scaling
- FLEX Series Mixed Signal Matrix
- Q Series FLEX multi-signal matrix

- 1 Series Switcher/Scalers

- T Series Control Consoles

- Subito Series LED Control Solutions

- UMS Series Media Solutions

- RMS Series Monitoring Solutions

- MSP Series Video Tools/Extenders Signal Converters Signal Distributors

- Accessories

- Software

- Reference

- Contact

# ASK Series



## ASK Collaboration System

Advanced Sharing and (K)ollaboration.

Transform any large display to in a collaboration device simply by connecting an ASK mini RX receiver.

Developed for performance and convenience, the RGBlink ASK™ collaboration system takes screen sharing to a new level for laptops, tablets and mobile devices.

Simply connect a compact ASK me TX transmitter to a Windows or macOS computer for fast, driver free connection to an ASK Receiver display with low latency, high frame rate and full colour gamut video without any compression or image loss. Other devices, simply connect with MiraCast or AirPlay to see video as it should be.

Display up to four devices on the display connected to an ASK Receiver and collaborate even further with the built-in Whiteboard features – ideal for large touch enabled displays. Connect multiple ASK Receivers to extend collaboration to multiple large screen displays, making ASK ideal across meetings and conferences, education and integration with live streaming events.



ASK mini TX



ASK mini RX



Compact, yet powerful and easy to use, ASK systems enable screen sharing and presentation applications for everyone. With no-lag full fidelity video up to 4K, presentations are immediate and engaging.



Connect and share from any device



Connect 4K display of up to 4096x2160@60Hz



Latency as low as 100ms



Up to 128 connected users



Share up to four screens simultaneously



Zero Config Auto-Pairing between Receiver and Transmitters



Simple Sharing Touch Control



Host Mode Control Features



Stable 802.11ac 212R Wi-Fi MIMO Connectivity



HDMI 2.0 & HDCP 2.2 Compliant



Encrypted Signal Protection

### Hi-Performance Automatically

The ASK system adapts automatically to the input video resolution, transmitting automatically with full YUV color gamut and 4:4:4 color space via the integral hardware video processing engine, providing maximum video performance and quality.

### Just ASK Connect

ASK Transmitters pair automatically with the Receiver with no user intervention required. Making use of Wi-Fi MIMO technology the ASK Receiver ensure a quality stable connection. Mobile and other devices simply connect the to ASK and use device standard MiraCast or AirPlay screen sharing.

### Touch to Share

Enabling screen sharing is as simply as touching the surface of an ASK transmitter, with a variety of operation states possible.

### TAKE Control

Hosts or key presenters are able to control sharing controls, set focus and mode, as well as take advantage of Whiteboard features.

## STREAMING

- CAPTURE
- SWITCHER
- ENCODER
- CLOUD/DECODER
- ASK Series Collaboration solutions

## PRO AV

- D Series Digital Processors
- X Series Universal Processors
- M Series Mixing & Scaling
- FLEX Series Mixed Signal Matrix
- Q Series FLEX multi-signal matrix

- 1 Series Switcher/Scalers

- T Series Control Consoles

- Subito Series LED Control Solutions

- UMS Series Media Solutions

- RMS Series Monitoring Solutions

- MSP Series Video Tools/Extenders Signal Convertors Signal Distributors

- Accessories

- Software

- Reference

- Contact



### **ASK Collaboration System**

RGBlink ASK nano puts the power of collaboration in your pocket with HDMI sticks and dongles that make screen sharing for laptops, tablets and mobile devices more convenient than ever.

Simply connect a compact ASK nano TX transmitter to a Windows or macOS computer for fast, driver free connection to an ASK nano RX receiver display – no lag, high frame rate, full rich colour video without compression.

ASK nano goes anywhere with no fuss wireless video sharing on demand everywhere.





Compact, yet powerful and easy to use, ASK nano systems enable screen sharing and presentation applications for everyone. With no-lag full fidelity video up to 4K, presentations are immediate and engaging.

 Strong device compatibility, support iOS/Android/Windows system applications

 Video transmission is less than 129 milliseconds delay

 Based on 802.11 AC 2T2R WIFI MIMO, stable connection

 1920x1080@60HZ Ultra HD

 Transmitter and receiver are automatically paired

 High reverse thrust protocol, transmission distance is more than 40 meters, signal can through the walls

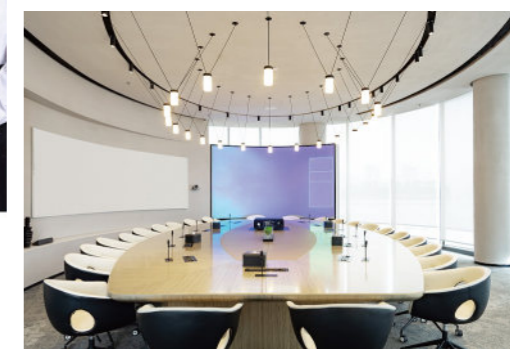

#### Plug and play

The transmitter can access or search for WIFI connection directly, do not need to install any drivers or applications.

#### Full color gamut

ASK nano supports video resolution adaptive and automatic transmission conversion, supports RGB color gamut hardware processing, suitable for maximum visual performance.

#### Wireless function

Based on 802.11 AC 2T2R WIFI MIMO wireless automatic pairing technology, ASK Nano also supports WIFI hot spot function connection, convenient to connect to mobile phone and Wireless PC terminal.

#### High sensitivity, low latency

Both transmitter and receiver adopt HDMI input interface. The signal transmission speed is much faster compare to the USB interface of the standard product in the market, and the transmitted signal source is higher sensitivity.

#### Simple and compact

The device is small in size and can be easily connected to the display screen and projector.

### STREAMING

- CAPTURE
- SWITCHER
- ENCODER
- CLOUD/DECODER

ASK Series  
Collaboration solutions

### PRO AV

- D Series  
Digital Processors
- X Series  
Universal Processors
- M Series  
Mixing & Scaling
- FLEX Series  
Mixed Signal Matrix
- Q Series  
FLEX multi-signal matrix

1 Series  
Switcher/Scalers

T Series  
Control Consoles

Subito Series  
LED Control Solutions

UMS Series  
Media Solutions

RMS Series  
Monitoring Solutions

MSP Series  
Video Tools/Extenders  
Signal Convertors  
Signal Distributors

Accessories

Software

Reference

Contact

# SCALE SWITCH ROUTE





I gave up everything for you

I gave up everything for you

# D Series

Presentation Processors



# D6

## For high performance 4K video end-to-end, D6 delivers

Modern presentations demand 4K at refresh rates supporting digital media. D6 builds on the tradition of its broadcast quality predecessors and RGBlink innovations while adding new and enhanced features.

RGBlink modular slots are utilised throughout for the ultimate in flexibility and configurability, with each slot supporting 4K 60fps and signal options including HDMI, DisplayPort and 12G SDI as well as conventional 2K signal options.

D6 features a large integrated touch screen display, not only for feature and configuration but also providing for video previews directly on board.

# D6

## Modular Design

D6 has four input and four output slots with each slot supporting up to 4K@60. A wide range of options are available including a digital input module with HDMI 2.0 and DisplayPort 1.2, a 12G-SDI module that supports multiple 3G-SDI inputs too.

## HDR Support

Signals with High Dynamic Range are supported for processing via the processor with D6 having a high bandwidth 60Gbps backplane and wide gamut 12bit grey level processing.

## Multi Layers Switching & Scaling

At the heart of presentation switching is true seamless switching of mixed signal types and resolutions. D6 scales and synchronises all video sources for output, and for switching operations seamless switches between preset and program. RGBlink pixel-to-pixel scaling engine presents pixel perfect video to non-native or creative displays as well as providing the multi-PIP/layer/window capabilities.

## Multi-Mode Operations

Select the operation mode suitable for the application from conventional Preview mode with seamless alpha cross fades, to Presentation Modes for the maximum layers and seamlessly fade-in-fade-out mixing, and videowall splicing modes. A range of presets allow quick and easy configuration to requirement.

## Full Color Space

Video scaling and conversion takes advantage of the RGBlink full 4:4:4 in hardware processing engine for the maximum visual performance.

## Image Enhancement

A full range of image enhancement controls are available on board including Noise Reduction, Gamma control, Hue, Tone, Color Temperature and more.

## Low Latency

Full hardware based video processing offers industry leading low cost latency across the processor.



## Dedicated Multi-View Preview

A built in preview feature allows review and configuration of video presets before TAKE to program. The multi-view is automatically configured for operation mode. Preview may be monitored from the front panel or viewed externally via the 2K preview output port independent of program output resolutions.

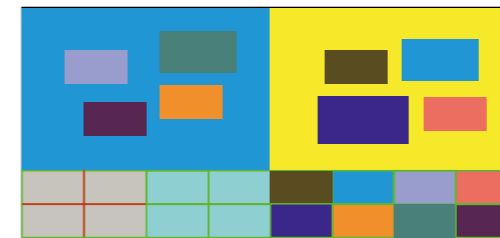

## Background Video

Select a source to be a background for the program output. Background is converted and scaled automatically to the full output resolution. Background video is ideal for Presentation Mode where many layers are utilised offering a canvas for fade-out-fade-in to occur against for maximum effect.

## Genlock

For synchronisation with other video devices, Genlock Y In is provided along with loop out.

## Chroma Key/DSK

Apply a key from presets or specify to requirement for foreground keying against the background layer.



## Connect and Control

Remotely configure and control D6 from XPOSE on Windows or macOS and via LAN or USB. RGBlink T Series control consoles may also be used for remote control, and for integrators RGBlink OpenAPI offers even further possibilities

## Control Local and Remote

The D6 front panel features large tactile and individually illuminated buttons as well as integral display. Uniquely the D6 front panel can be removed either for security or located and connected remotely increasing operational flexibility.



\* D6 shown with



optional modules fitted as example

## STREAMING

- CAPTURE
- SWITCHER
- ENCODER
- CLOUD/DECODER
- ASK Series Collaboration solutions

## PRO AV

- D Series Digital Processors
- X Series Universal Processors
- M Series Mixing & Scaling
- FLEX Series Mixed Signal Matrix
- Q Series FLEX multi-signal matrix

- 1 Series Switcher/Scalers
- T Series Control Consoles
- Subito Series LED Control Solutions

- UMS Series Media Solutions
- RMS Series Monitoring Solutions
- MSP Series Video Tools/Extenders Signal Convertors Signal Distributors

- Accessories
- Software
- Reference
- Contact

# D4

## The standard in multi-format 4K presentation switching

Designed for 4K video switching for professional applications, D4 is a very flexible switching and scaling solution dual configurable 4K output channel. On board is a comprehensive set of features to process the video requirements of modern 4K signals including those supporting HDR.

Truly multi-signal, D4 may be fitted with a wide range of input signals including HDMI 2.0, DisplayPort 1.2 and 12G-SDI, along with conventional 2K signals.

Fully modular, outputs can be duplicated too via the option slot.

Full 4:4:4 YUV and 12 bit on board processing engine, D4 meets the highest performance standards. Whether scan conversion, scaling, seamless presentation switching, or stitching D4 is ideal for performance and broadcast workloads.



# D4

### Multi-Signal 4K Switching

Highly modular, D4 allows varying 4K signal sources to be synchronised and presented for output and switched seamlessly on demand. Input options include HDMI 2.0, DisplayPort 1,2 & 12G-SDI.

### Format

D4 accepts all common 2K & 4K input formats, with EDID management built in. Output to any 2K or 4K format with custom resolutions able to be specified to down stream requirements.

### HDR

Signals with High Dynamic Range are supported for processing via the processor with high bandwidth and wide gamut 12bit grey level processing.



### Full Colour Gamut

The D4 advanced video engine offers 12bit YUV4:4:4 processing delivering rich vibrant colours avoiding pre-output compression for superior image performance.

### Pixel to Pixel Scaling

Scale outputs to any size in the set output resolution.

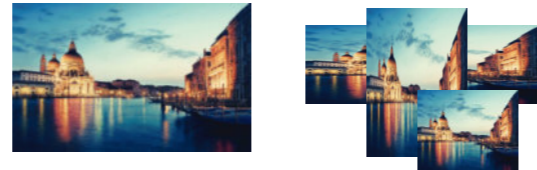

### Output Splicing

Split output across the dual output channels providing an 8K x 2K display canvas and seamless pixel to pixel hard edge blend.

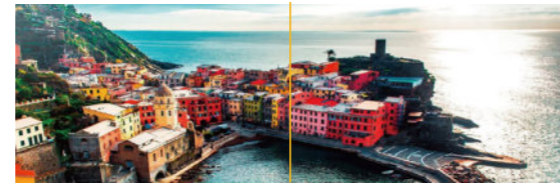

### Multi-Layer 4K Video

Make use of multiple video sources with operation modes for PIP over background presentation mode.



### Dual 4K Output Channels

D4 is standard with two 4K / HDMI 2.0 outputs configurable in resolution and operation mode. Outputs may be duplicated to optional secondary outputs as HDMI, DisplayPort or SDI.

### Mirror/Flip

Horizontally or vertically mirror or flip output up to 8K2K. D4 is ideal for projection applications with large format projectors.



### Crop & Position

Select X and Y offsets along with width and height to select any image part for output.



### Visual Enhancements

Apply a range of visual effects and enhancements with fine grain controls.

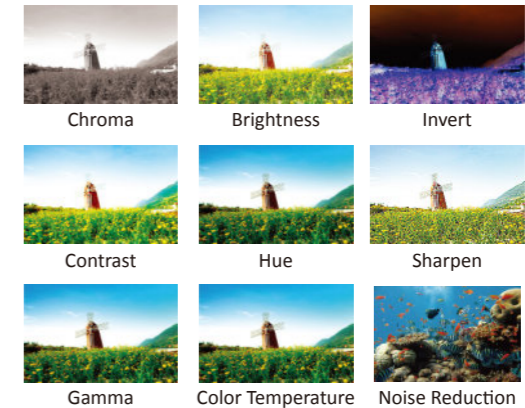

### Genlock

Sync and frame lock with Genlock Y at up to 4K with selectable resolution. A loop through is provided allowing D4 to sync inline.

### Intuitive Controls

Configure and control D4 conveniently from the front panel, remotely over a LAN with RGBlink XPOSE or any controller via the RGBlink OpenAPI.



## STREAMING

- CAPTURE
- SWITCHER
- ENCODER
- CLOUD/DECODER
- ASK Series Collaboration solutions

## PRO AV

- D Series Digital Processors
- X Series Universal Processors
- M Series Mixing & Scaling
- FLEX Series Mixed Signal Matrix
- Q Series FLEX multi-signal matrix

## 1 Series Switcher/Scalers

## T Series Control Consoles

## Subito Series LED Control Solutions

## UMS Series Media Solutions

## RMS Series Monitoring Solutions

## MSP Series Video Tools/Extenders Signal Convertors Signal Distributors

## Accessories

## Software

## Reference

## Contact

# VSP 628PRO

## Standard in 2K presentation switching

With unrivalled features and performance, VSP628pro is sophisticated yet easy to use. Flexible in operation, with multiple operation modes, the processor is capable of supporting a wide range of usage scenarios across scaling, presentation switching, cross conversion and more.

True two channel design supports the up to eight inputs covering all common signal types including 3G-SDI, HDMI, DisplayPort and more.

VSP628pro offers best-in-class visual performance from the RGBlink video processing engine, and coupled with features such flip, rotate and Chroma Key, along with EDID management and Genlock the processor is a comprehensive solution platform for professional applications.



# VSP 628PRO

## Format

VSP628pro supports all common formats up to 2560x1600 @ 60Hz. Additionally VSP628pro allows users to specify any custom output resolution within this range.

## Position, Scale, Crop & Zoom

The foreground layers (or PIP's) can be positioned, scaled pixel-by-pixel, cropped and zoomed freely.

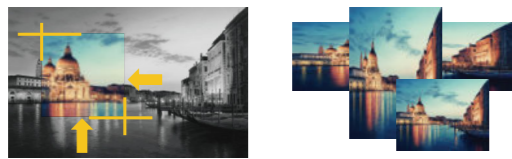

## Flip, Mirror, Rotate

Make use of powerful controls to deliver video content to displays in portrait as well as rear projection application. VSP628pro has built-in functionality for mirror, flip and 90 deg increment rotations.

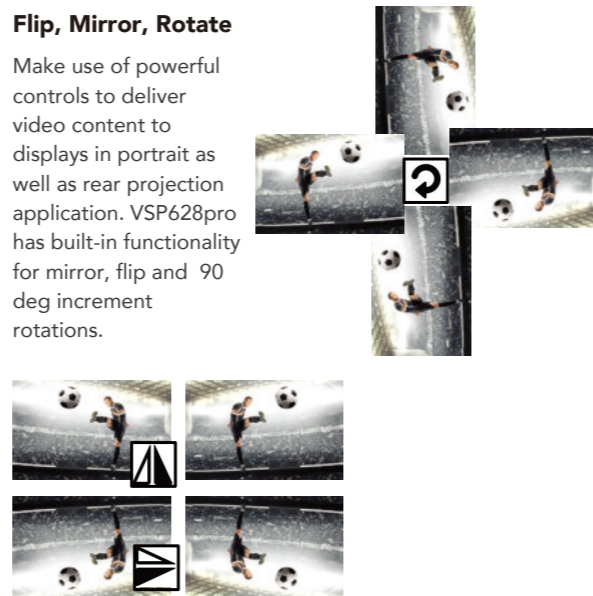

## DSK/Chroma Key

On PIP, DSK or a Chroma Key can be applied, ideal for logos, overlays or masking.



## Expand Inputs

VSP628pro has an input slot, with a wide range of options available including SDI, HDMI, DVI, VGA, CVBS, USB media as well as 4K for DisplayPort/HDMI.

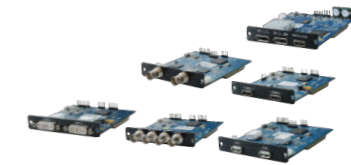

## Visual Effects

Apply a range of built-in visual effects and enhancements. Including Chroma, Brightness, Contrast, Hue, Gamma, Colour Temperature, Inversion, Sharpness and Noise Reduction.



## Output Expansion

The output slot supports either a standard LED Sender Card (which can then be controlled directly from on board VSP628pro) or an output option – either the two channel SDI module or single channel SDI/Fiber/HDBaseT module.



## Flexible Processor Operations

VSP628pro operation modes provide a high level of configurability allowing an extremely wide range of usage application, making the device ideal for demanding events and broadcast applications alike.

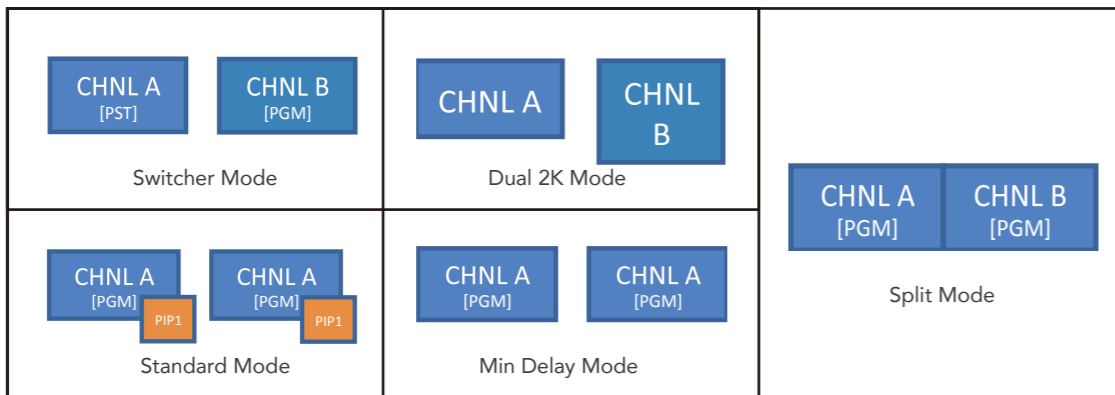

## EDID Management

Each compatible input can be individually configured for EDID with read and save operations.

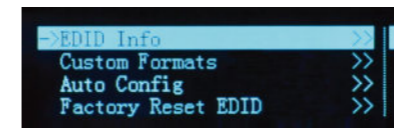

## Connect and Control

Remotely configure and control VSP628pro from XPOSE on Windows or macOS via LAN or USB. Install the app for iOS or Android to for even more convenient portable control.

## Genlock

Genlock Y in is included enabling synchronised operations across connected video devices



## STREAMING

- CAPTURE
- SWITCHER
- ENCODER
- CLOUD/DECODER
- ASK Series Collaboration solutions

## PRO AV

- D Series Digital Processors
- X Series Universal Processors
- M Series Mixing & Scaling
- FLEX Series Mixed Signal Matrix
- Q Series FLEX multi-signal matrix
- 1 Series Switcher/Scalers
- T Series Control Consoles

## Subito Series LED Control Solutions

## UMS Series Media Solutions

## RMS Series Monitoring Solutions

## MSP Series Video Tools/Extenders Signal Convertors Signal Distributors

## Accessories

## Software

## Reference

## Contact



新华通讯社  
CNC  
A New Perspective  
XINHUA  
NEWS AGENCY



NOVO TEL

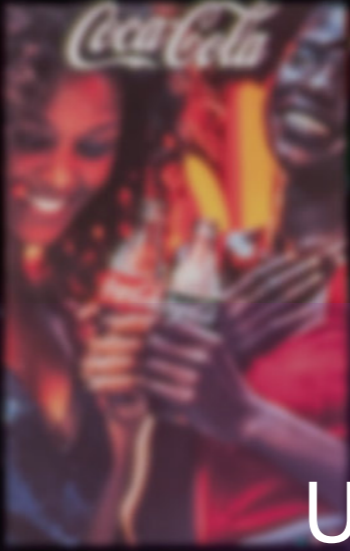

**X Series**  
Universal Processors

IONIQ



## UNIVERSAL VIDEO PROCESSOR

For large scale video applications, X20 takes hardware-based processing to a whole new level. Ideal for complex applications with diverse signals and resolutions, X20 brings together up to 160 video sources for display across up to a massive 144 outputs in a single robust and modular frame.



### 4K Native

X20 includes support for common 4K signal types including Dual Link DVI, HDMI and DisplayPort. High resolution signals may be combined with other resolutions to create windows/layers out output display areas.



### Multi-Layer / Multi-Window

With up to eight layers per output slot, windows may be created for any scale, crop, or position. Windows may overlap others as well extend across outputs while tear-free and maintaining completely in sync.

### 300 Mega Pixel Canvas

For even the largest displays and display systems, X20 has the capacity to create and deliver on the most ambitious possibilities. Power multiple displays of 8K, 16K and more.

### Remote Control & Configuration

All features of X20 may be accessed from the acclaimed RGBlink XPOSE 2.0 software application that features a rich graphical UI. Additionally, X20 may also be integrated in BMS or other control systems using UDP, via the RGBlink OpenAPI.

### Hi-Availability Operations

Modularity extends to high performance server-grade power supplies included with X20. For fully power redundant operations, X20 offers slots for secondary power supplies too.

### Real Time Data Protection

All current settings are stored in static memory for immediately resumption in the event of recovery from a power loss.

### Display Container Management

Create and manage independent output display areas (containers) across multiple outputs, each display area as a virtual pixel space is able to make use of any source and be managed independently from other containers.

### Preview Remotely

Configure X20 interactively with source video previews to RGBlink XPOSE control software from dedicated outputs injecting IP video.

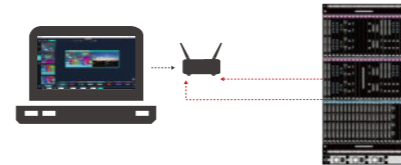

### Modular by Design

Combine multiple signal types by fitting input and output modules, select from a wide range of signal types.

### OSD

Apply text, messaging and subtitles using On-Screen-Display of text as overlays as banners or text only. OSD text is stored on board X20 for recall on demand.

### High-Capacity System

X20 card-frame style SmartSlots™ provide for up to 40 input and 36 output modules. The system architecture supports hot-swap of modules with auto-detection of inserted module type.



## STREAMING

- CAPTURE
- SWITCHER
- ENCODER
- CLOUD/DECODER
- ASK Series Collaboration solutions

## PRO AV

- D Series Digital Processors
- X Series Universal Processors
- M Series Mixing & Scaling
- FLEX Series Mixed Signal Matrix
- Q Series FLEX multi-signal matrix
- 1 Series Switcher/Scalers
- T Series Control Consoles
- Subito Series LED Control Solutions
- UMS Series Media Solutions
- RMS Series Monitoring Solutions
- MSP Series Video Tools/Extenders Signal Convertors Signal Distributors

- Accessories
- Software
- Reference
- Contact



## 160 Mega Pixel Video Display System

For entire video display systems, X14 brings a new level of efficiency, capability and control. Supporting up to massive 52 inputs and up to 40 outputs, X14 truly brings together large video systems for system-in-box approaches to video presentation and integration.

Modular throughout RGBlink technologies support user fit input and output signals with each slot configurable up to 4K/UHD resolutions at full frame rates. With so many inputs, windowing and layering capabilities are dramatically enhanced with an output canvas of up to 160 mega pixel layer processing.

Dedicated preview functionality is available both remotely via XPOSE and on the inbuilt LCD display with XPOSE embedded directly into the processor for monitoring control capabilities.



### Multi Role, Multi Application

Select the operation mode suitable for the application from continuous video wall mode to presentation mode and routing modes. There is also processing capabilities for 3D and mixed device application.

### Modular Design

X14 has 52 input slots which may be configured with universal quad modules. Similarly for output universal quad modules maybe fitted to any of the ten slots for 40 2K output, 10 4K outputs or a combinations of both. A wide range of signal options are available including digital input and output modules, SDI up to 12G and conventional signal types.

### Full Color Space

Video scaling and conversion takes advantage of the RGBlink full 4:4:4 in hardware processing engine for the maximum visual performance.



### HDR Support

Process and scale High Dynamic Range signals with selected modules retaining full gamut.



### Preview on Board

The integrated LCD display allows live source and output video monitoring as well as signal status

### Local Controls

Use the built-in in touch screen to not only monitor an X14, but also control selected features and operations directly from the device.

### Streaming Preview

Manage, operate and monitor with live source previews streamed directly into RGBlink XPOSE

### 4K / UHD Support

Select from digital input and output options including HDMI and DisplayPort.



### Video Over IP

X14 includes options for video over ethernet standards including HDBaseT modules allowing direct connection to displays without conversion.

### Rotate & Flip

Rotate outputs in 90deg increments, flip, invert. X14 also supports RGBlink ARO™ modules for advanced 1 degree rotation and edge



### Chroma Key/DSK

Apply a key from presets or specify to requirement for foreground keying against the background layer.



### Connect & Control

Unleash powerful onboard capabilities with remote configuration and control via RGBlink XPOSE or BMS controllers with RGBlink OpenAPI

### Video Display as a System

X14 is unique adaptable to multi-role systems with the capacity for both a large number of inputs and outputs. The range of user-fit modules allows X14 to be customised on demand and brings together usually diverse display solutions as a signal system reducing complexity, reducing the need for ancillary equipment and enhancing overall system performance. Multiple operation modes allow X14 to be deployed in a wide range of applications.

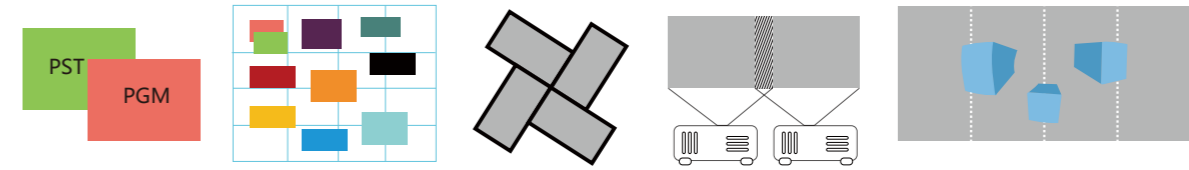

### Stich & Splice Video Walls

Seamlessly, in complete sync, display video across a display canvas of multiple outputs

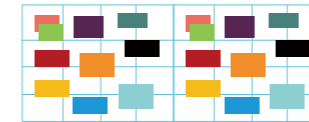

### Presentations with Confidence

Make use of system modes with full active PST and PGM operations

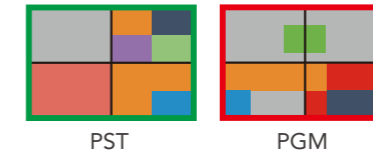

### Deliver in 3D

Process 3D signals for display across large pixel spaces over multiple outputs

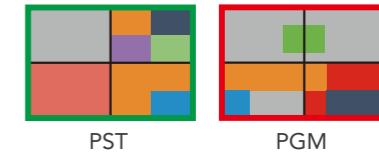

### 160 Mega Pixel Display Area

Arrange outputs on a virtual canvas to create very large display surfaces with 2K and/or 4K components or build multi-display systems synchronised or as independent display containers.

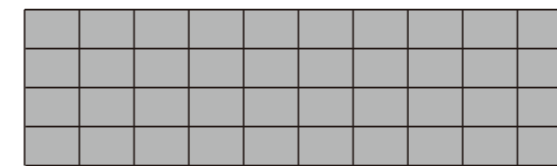

### Windowing & Video Layers

Display up to 160 video layers from any combinations of signals or sources. All video presented to output is fully synchronised and converted for output across the output channels.

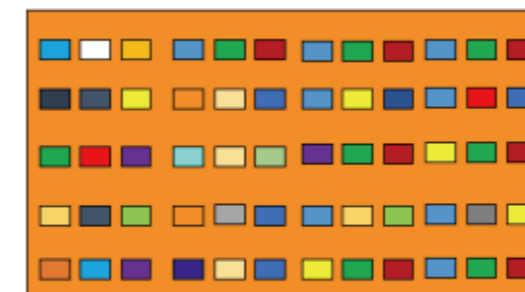

### STREAMING

- CAPTURE
- SWITCHER
- ENCODER
- CLOUD/DECODER
- ASK Series Collaboration solutions

### PRO AV

- D Series Digital Processors
- X Series Universal Processors
- M Series Mixing & Scaling
- FLEX Series Mixed Signal Matrix
- Q Series FLEX multi-signal matrix

- 1 Series Switcher/Scalers

- T Series Control Consoles

- Subito Series LED Control Solutions

- UMS Series Media Solutions

- RMS Series Monitoring Solutions

- MSP Series Video Tools/Extenders Signal Convertors Signal Distributors

- Accessories

- Software

- Reference

- Contact



# X<sub>8</sub>

## **Redefining 8K Video Processing**

Industry leading X series video processing platform takes a massive step into the 8K future with X8. Designed and built for demanding high performance where 4K is the norm, X8 provides unparalleled multi-signal compositing, sync and switching with low latency while maintaining and enhancing visual fidelity.



### Up to 48 4K Layers

Take advantage of powerful multiple 4K layers – output up to 48 scaled layers/windows on a fully configured system across 12 4K outputs, with up to eight 4K layers on any output port.

### 8K Source Management

Splice 4K inputs and outputs for 8K operations fully in sync and glitch free, retaining the rich visual content even when scaled.

### Seamless 4K & 8K Switching

Open, switch and transition video layers seamlessly with full sync even across multiple outputs. Transition between multi-signal, multi-scene presets, and PIP over background layers, bringing together 4K and spliced 8K sources on demand.

### Full Color Space

Process high resolution video without compression or loss. X8 is 4:4:4 native with wide bandwidth in device to process high quality video without compromise. Up-sampling of 4:2:0 and 4:2:2 content to 4:4:4 is also supported

## Live Virtual Control

RGBlink XPOSE 2.0 provides an industry, intuitive to use configuration and control platform for advanced RGBlink processors including X8.

Signals can be previewed live, multiple display system containers built, presets created and managed. Playback facilities include live and broadcast style as well as scheduled timeline-based options and more.

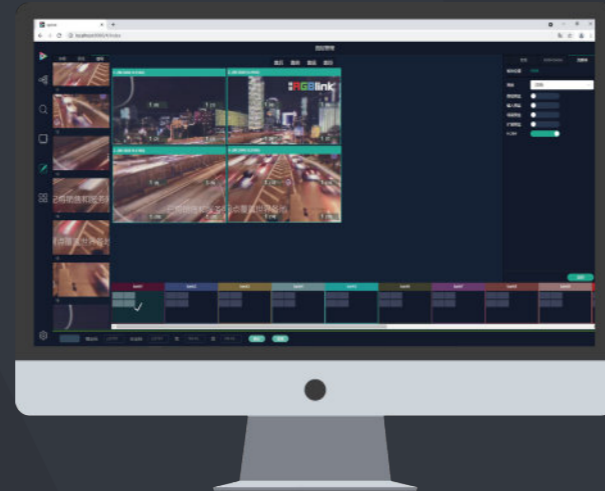

### Seamless Synchronization

RGBlink technologies ensure high performance very low latency hardware-based video processing. Synchronisation and delivery of signals of any resolution across multiple outputs is tear-free and scaled pixel-to-pixel.

### Build for Integration

Leverage RGBlink OpenAPI to connect from almost any platform, allowing integration capabilities that go way beyond simply triggering presets or scenes.

### Powerful Display Systems Controls

Unlock unique and extensive device capabilities with the RGBlink XPOSE 2.0 control platform built right into X8 and accessible via a web browser. Create entire display systems comprised of not only multiple resolution displays but also displays of any format or type.

### Native IP Streaming

Stream H.264 video sources via the LAN port providing live previews in browser connected XPOSE 2.0 configurations, presets and playlists.



### Lower TCO

Fit modules and components to the X8 system without unneeded overhead or bloat. Hot swap and exchange input and output modules without powering down the overall system. The modular design enables higher up times, ease of maintenance, and operational efficiencies.

### World Leading Development

RGBlink designs, develops and manufactures in house, with unique capabilities and draws from the extensive RGBlink IP pipeline and experience in creating the advanced capabilities in the X8 processing platform.

#### STREAMING

- CAPTURE
- SWITCHER
- ENCODER
- CLOUD/DECODER
- ASK Series Collaboration solutions

#### PRO AV

- D Series Digital Processors
- X Series Universal Processors
- M Series Mixing & Scaling
- FLEX Series Mixed Signal Matrix
- Q Series FLEX multi-signal matrix
- 1 Series Switcher/Scalers
- T Series Control Consoles
- Subito Series LED Control Solutions
- UMS Series Media Solutions
- RMS Series Monitoring Solutions
- MSP Series Video Tools/Extenders Signal Converters Signal Distributors

#### Accessories

#### Software

#### Reference

#### Contact





### · High Performance Backplane

Maintaining full 4K60 4:4:4 for all signals, the X8 backplane and cross-point offers extreme bandwidth to ensure pixel perfect delivery at every resolution and format.

### · Genlock Sync

Synchronise and Genlock to other devices in a video system, with X8 accepting BlackBurst in.

### · Configurable Preview

The dedicated HDMI is configurable for up to 64 windows for the ultimate in local monitoring capability.

### · Extreme Resolutions

X8 supports 8K multi-cable ultra-high resolution sources in conventional and panoramic configurations, as well as standard 4K and 2K signal formats. For display, configure ultra large displays across multiple 4K outputs using multiple video layers

### · Seamless Video Switching

All switching is seamless with no black frames and is glitch/tear free across multiple outputs. Switch between presets with fades and cuts, as well as using transition effects.

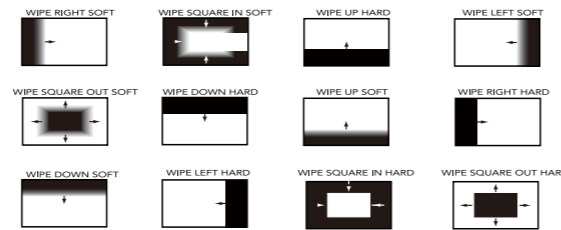

### · Audio Support

Select embedded audio from any source for re-embedded to any display output.

### · Low Latency Cross Conversion

With the best up-down processing engine in the industry, RGBlink offers the widest signal support capabilities and supports unique custom configured resolutions allowing even more video to be controlled, synchronised and delivered to any display.

## Quality without Compromise

Maintain the highest fidelity of source signals without compression or loss with 4:4:4: YUV/RGB colour space.

Manage video chroma sub-sampling and up-sampling of 4:2:0 and 4:2:2 sources for maximum flexibility.



RGBlink X8

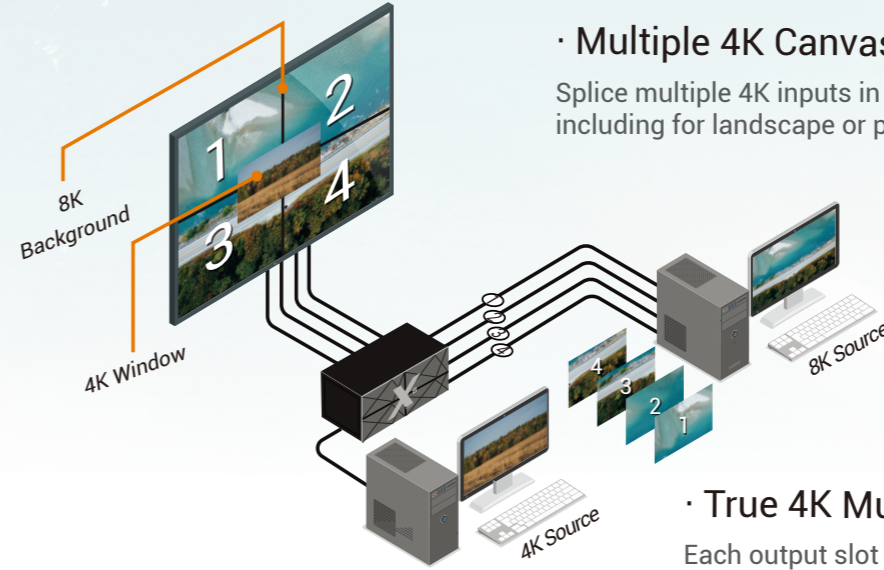

### · 8K Workflow Support

Manage multiple 8K sources and output displays combining with other content as needed.

### · Multiple 4K Canvas

Splice multiple 4K inputs in any configuration including for landscape or panoramic arrangements.

### · True 4K Multi-Layer Windowing

Each output slot in X8 supports eight 4K60 layers which maybe assigned freely across outputs, including as eight 4K layers on single 4K output.

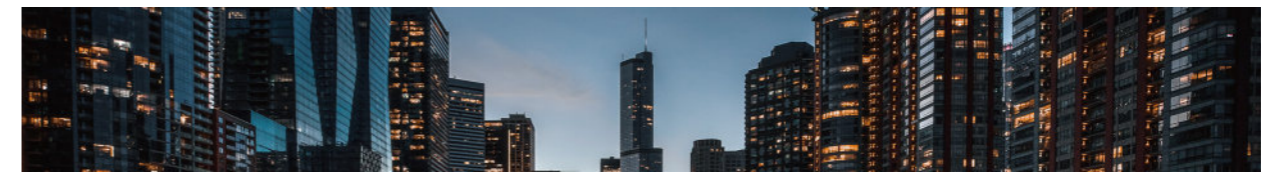

#### STREAMING

- CAPTURE
- SWITCHER
- ENCODER
- CLOUD/DECODER
- ASK Series Collaboration solutions

#### PRO AV

- D Series Digital Processors
- X Series Universal Processors
- M Series Mixing & Scaling
- FLEX Series Mixed Signal Matrix
- Q Series FLEX multi-signal matrix
- 1 Series Switcher/Scalers
- T Series Control Consoles
- Subito Series LED Control Solutions
- UMS Series Media Solutions
- RMS Series Monitoring Solutions
- MSP Series Video Tools/Extenders Signal Convertors Signal Distributors
- Accessories
- Software
- Reference
- Contact



## Flexible Canvas Assignment

The ultimate in flexibility, create layouts in pixel space canvas, mapping sources as layers across positioned displays.

Save and recall layouts and presets on demand for visually engaging experiences powered at the edge with RGBlink X8.

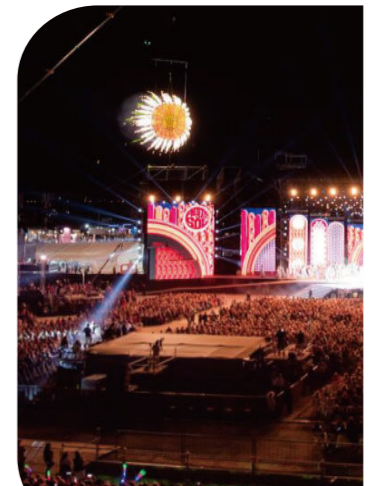

### STREAMING

- CAPTURE
- SWITCHER
- ENCODER
- CLOUD/DECODER
- ASK Series Collaboration solutions

### PRO AV

- D Series Digital Processors
- X Series Universal Processors
- M Series Mixing & Scaling
- FLEX Series Mixed Signal Matrix
- Q Series FLEX multi-signal matrix
- 1 Series Switcher/Scalers
- T Series Control Consoles
- Subito Series LED Control Solutions
- UMS Series Media Solutions
- RMS Series Monitoring Solutions
- MSP Series Video Tools/Extenders Signal Convertors Signal Distributors

- Accessories
- Software
- Reference
- Contact



# X<sub>7</sub>

## Large scale video wall processing

Bring together entire video display systems with X7. With up to 32 outputs and a 64 mega pixel capacity, X7 is equally at home delivering fully synchronised video to large video walls or multiple video walls and creative displays of all types.

X7 is a true multi-window / multi-layer video wall solution. Connect and configure input sources just once while routing, scaling positioning and presenting across multiple outputs or display areas.

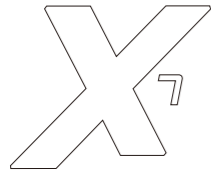

### Multi-Mode Operations

X7 outputs can be configured in one or multiple modes, with pixel space allocated to each mode as a virtual container. Operation modes include Matrix, Video Wall, Presentation, 3D, Rotation and Blending.

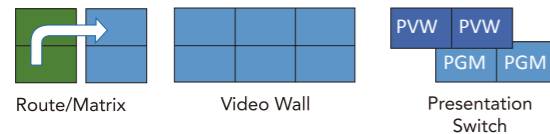

### Configure Outputs

Set the output resolution and scale to multiple display sizes, take advantage of outputs arranged in multiple container/display areas for flexible multi-display use.

### Modular by Design

All X7 inputs and outputs are modular and hot swappable. Arranged in slots, each slot supporting a 4K signal or four 2K signals. A wide range of signal options available allowing native connections.

### LOGO/Frame Capture

Capture a frame and store on board for recall on demand, including for use as fallback.

### Remote Control

Control X7 from RGBlink XPOSE, XPOSE mobile or T Series consoles. For integrators, control via RGBlink OpenAPI is also available.

The XPOSE control platform provides intuitive rich controls unlocking and enabling powerful video control scenarios on the X7 hardware processing platform.

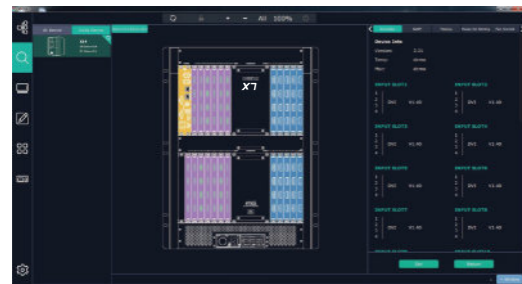

### UHD 4K 60Hz Signal Support

RGBlink 4K input and output modules may be used with X7. 4K@60 Digital inputs include HDMI 2.0 and DisplayPort 1.2, and 12G SDI is also available. 4K @60 outputs include HDMI 2.0 and 12G SDI. X7 supports HDCP 2.2.



### Full Color Space

Internal high bandwidth processing maximises quality and with 4:4:4 color space support.

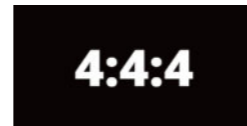

### H.264 video stream

Stream video input sources via dedicated H.264 ports. Display source previews in XPOSE or video players. Customise port configurations to suit the application.



### Rotate with Precision

Fit ARO™ Advanced Rotation Output modules to orient video in support of physically rotated and creativity arranged displays. ARO outputs may be rotated in 1-degree increments and positioned in pixel space. Use zoom to support display of differing density.

### Synchronise

X7 includes both Genlock and HDMI Digital Reference inputs, allowing a variety of synchronisation scenarios.

### Preview Sources

Install up to four PVW source preview modules in any of the X7's output slots to stream video sources to XPOSE or third-party clients. Connect the display via DVI for local multi-view source monitoring.

### Presentation Switching

Preview presets (PST) and TAKE to PGM in broadcast style with controller of choice.

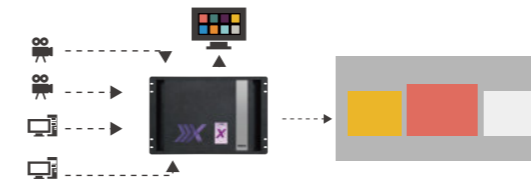

### Creative Displays

With RGBlink ARO modules fitted, map video across displays arranged physically on a virtual canvas or pixel space

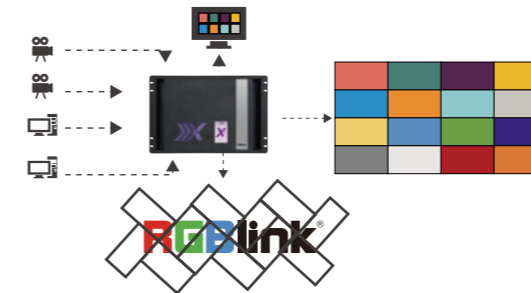

### 128 Mega Pixel Splicing

Fit up to 32 2k or 16 4k outputs to create continuous video walls in any arrangement with all video fully synchronised to the outputs, pixel-to-pixel. Use with displays including LED, LCD and projection.

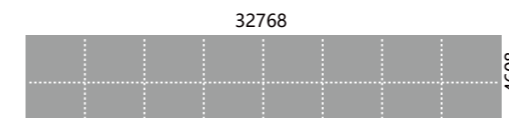

### Multi-Layer | Multi-Window

Output video layers or windows scaled and positioned across one or more outputs. A fully configured X7 can support up to 64 layers (or 256 layers if all outputs are H.264 modules).

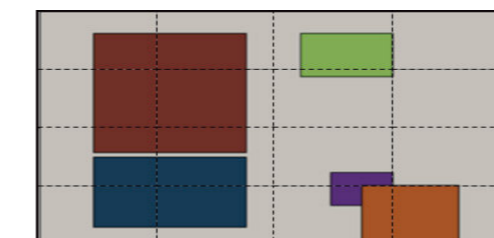

### Video Wall Display & Control

Create and display a seamless stitched video wall with continuous or dynamic content.

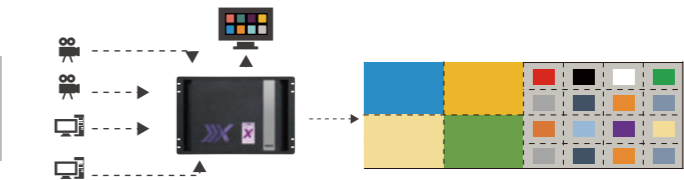

### Large Scale Projection

Blend video from the X7 with RGBlink ARO to projection displays arranged in almost any configuration.

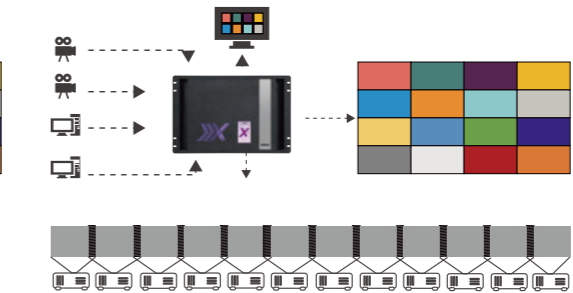

### Host & Manage Display Systems

Bring together displays with a single video processor controller with coordinated or independent control and efficient single source processing.

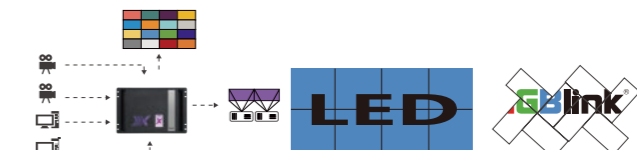

## STREAMING

- CAPTURE
- SWITCHER
- ENCODER
- CLOUD/DECODER
- ASK Series Collaboration solutions

## PRO AV

- D Series Digital Processors
- X Series Universal Processors
- M Series Mixing & Scaling
- FLEX Series Mixed Signal Matrix
- Q Series FLEX multi-signal matrix

- 1 Series Switcher/Scalers

- T Series Control Consoles

- Subito Series LED Control Solutions

- UMS Series Media Solutions

- RMS Series Monitoring Solutions

- MSP Series Video Tools/Extenders Signal Convertors Signal Distributors

- Accessories

- Software

- Reference

- Contact



### High performance video wall processing

X3 universal processors are 16x8 scalable videowall control solutions that are dynamically configurable to meet the demands of high-resolution modern displays. The high performance 12bit 4:4:4 processing engine delivers video scaled pixel-to-pixel to multiple outputs that are seamlessly spliced and fully synchronised. A dedicated, high-speed video/graphic bus maintains real-time performance even regardless of the signal load or type.



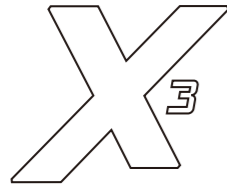

### Multi-Layer | Multi-Window

Output video from multiple sources as layers or windows scaled and positioned across the output pixel space.

### Multi-Mode Operations

X3 outputs can be configured for a range of operation modes including Matrix, Video Wall, Presentation, 3D, Rotation and Blending.

### Preview Sources

Fit up to two PVW source preview modules to the dedicated slot on an X3p to stream video sources to XPOSE or 3rd party clients. Connect a display via DVI for a local multi-view source monitoring.

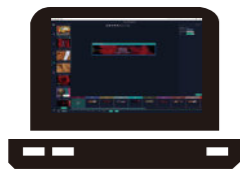

### Remote Control

Control from RGBlink XPOSE, XPOSE mobile or T Series consoles. RGBlink OpenAPI allows X3 to be integrated and controlled from almost any system.



### UHD 4K 60Hz Signal Support

Select input and output modules for 4K60 signals – options include HDMI 2.0, DisplayPort 1,2 and 12G-SDI



### Configure Outputs

Set the output resolution and scale to present video pixel-to-pixel on displays of all sizes.

### Modular by Design

All inputs and outputs on the X3 & X3p are modular and hot swappable. Arranged in slots, each slot supporting a 4K signal or four 2K signals. A wide range of signal options available allowing native connections.

### LOGO/Frame Capture

Capture a frame and store on board for recall on demand, including for use as fallback.

### OSD

Overlay text in almost any font and style, with or without key. On Screen Display text is stored on board.

### DSK / Chroma Key

Remove a background from a foreground layer using a preset or manually select color values.



### Video Wall Display & Control

Create and display a seamless stitched video wall with continuous or dynamic content.

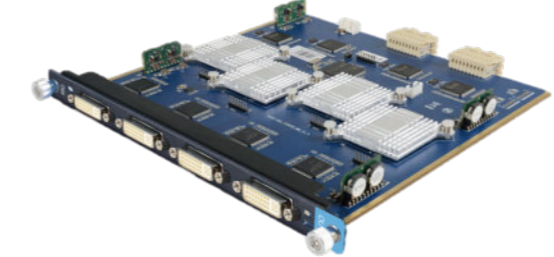
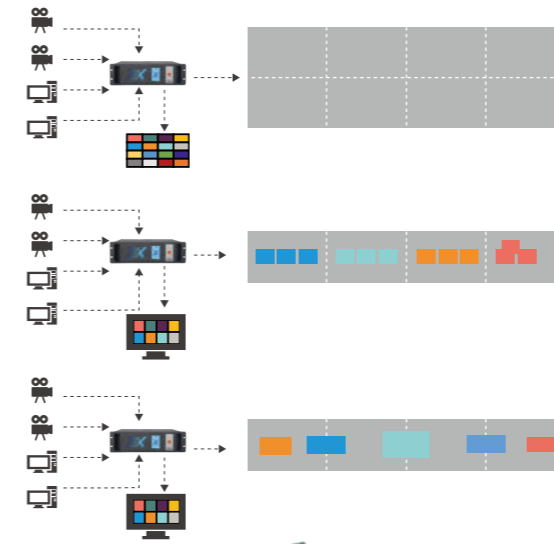

### Rotate with Precision

In addition to 90-degree rotation and Fit ARO™ Advanced Rotation Output modules to orient video in support of physically rotated and creativity arranged displays. ARO outputs may be rotated in 1-degree increments and positioned in pixel space. Use zoom to support display of differing density.

### Synchronise

Genlock and HDMI digital reference inputs are provided, allowing synchronisation with other devices in the system



### Presentation Switching

Preview presets (PST) and TAKE to PGM in broadcast style with controller of choice

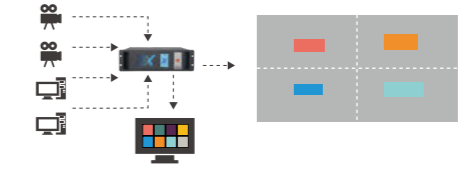

### Creative Displays

With RGBlink ARO modules fitted, map video across displays arranged physically on a virtual canvas or pixel space

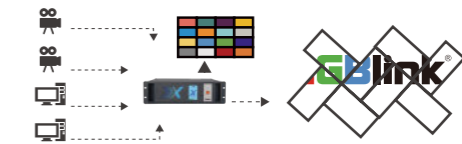

### Large Scale Projection

Blend video from the X7 with RGBlink ARO to projection displays arranged in almost any configuration.

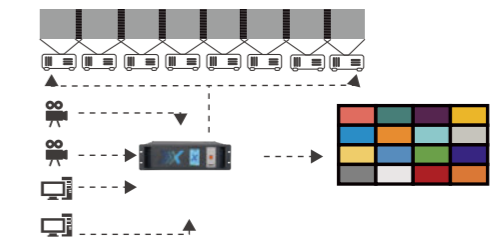

## STREAMING

- CAPTURE
- SWITCHER
- ENCODER
- CLOUD/DECODER
- ASK Series Collaboration solutions

## PRO AV

- D Series Digital Processors
- X Series Universal Processors
- M Series Mixing & Scaling
- FLEX Series Mixed Signal Matrix
- Q Series FLEX multi-signal matrix

- 1 Series Switcher/Scalers
- T Series Control Consoles
- Subito Series LED Control Solutions

- UMS Series Media Solutions

- RMS Series Monitoring Solutions
- MSP Series Video Tools/Extenders Signal Convertors Signal Distributors

- Accessories
- Software
- Reference
- Contact



# X<sub>2</sub>

## Modular Video Wall Control

Beautifully designed and compact, X2 is ideal for fixed pro AV and integration applications. Universal routing and scaling built on innovative RGBlink technologies, X2 has a fully modular input and output structure supporting up to 16x16 inputs and outputs, allowing the processor to be configured to specific applications with low overhead.

Control and configuration is achieved via a ethernet interface in conjunction with XPOSE®, XPOSE mobile or RGBlink OpenAPI. Configure X2 for routing and matrix operations or for video wall applications, including spliced displays with bezel offset support.



### Smart Scaling & Routing

Bring together a diverse range of signal types and resolutions for presentation to outputs whether for continuous displays or routing applications

### Splicing

Arrange video layers across multiple outputs with fully synchronised spliced outputs pixel-for-pixel.

### Modular by Design

Designed with the integrator in mind, all X2 inputs and outputs are modular and hot swappable. Arranged in slots, each slot supports up to four 2K inputs, with a wide range of signal options available allowing native connections minimising the need for converters or adapters.

### H.264 video stream

Stream video input sources via dedicated H.264 ports. Display source previews in XPOSE or video players. Customise port configurations to suit the application.

### Configure, Control, Integrate

Use RGBlink XPOSE to fully configure X2 while maintaining all settings and presets on board the X2 hardware-based processing platform. Control and integrate using XPOSE or RGBlink OpenAPI.



### Configurable Outputs

Set the output resolution and scale to multiple display sizes, whether for LCD, projection or LED.



### LOGO/Image Capture

Capture a frame and store on board for recall on demand, including for use as fallback.

### Rotate

Rotate outputs in 90 degree increments in support of displays installed in non-standard orientations.

### Store Settings

All settings including presets are stored on board, these configuration files may also be download and stored of line.



### Video Walls

Preview presets (PST) and TAKE to PGM in broadcast style with controller of choice

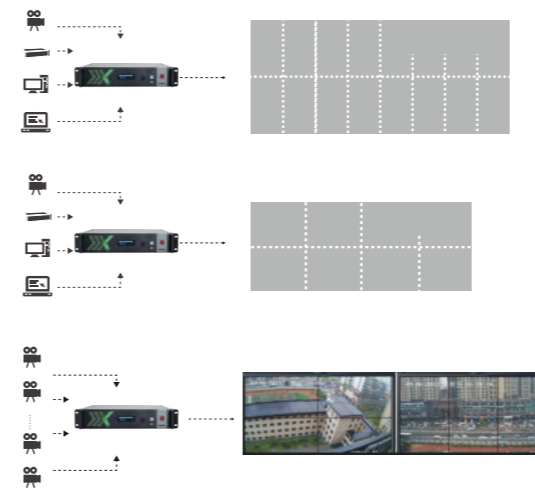

### Cost Effective High Availability Platform

X2 is ideal for applications including commercial and retail digital signage, as well as for control rooms and monitoring, with support for dual power supplies and redundant operations. The wide range of module options insures not only bespoke configuration with no overhead, but also ease maintenance and support.

### Presentation Switching

Preview presets (PST) and TAKE to PGM in broadcast style with controller of choice

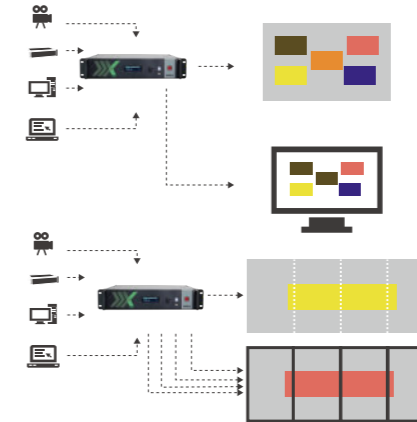

### Matrix Routing

Route signals to any output, including HDBaseT and H.264 destinations.

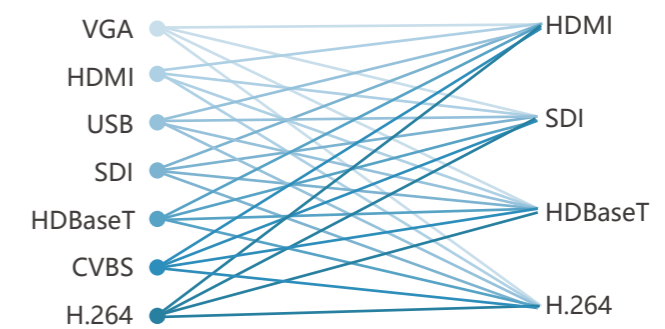

## STREAMING

- CAPTURE
- SWITCHER
- ENCODER
- CLOUD/DECODER
- ASK Series Collaboration solutions

## PRO AV

- D Series Digital Processors
- X Series Universal Processors
- M Series Mixing & Scaling
- FLEX Series Mixed Signal Matrix
- Q Series FLEX multi-signal matrix
- 1 Series Switcher/Scalers

- T Series Control Consoles

- Subito Series LED Control Solutions

- UMS Series Media Solutions

- RMS Series Monitoring Solutions

- MSP Series Video Tools/Extenders Signal Convertors Signal Distributors

- Accessories

- Software

- Reference

- Contact



# M Series

Mixing & Scaling



# M3

## Video Control on Demand

Bringing together sophisticated presentation switching with advanced mixing capabilities into a single device, this vision mixer console includes broadcast style features for quick usage and access for any event or presentation. Integral dual eight-inch LCD displays provide monitoring of video sources, full preview, and program outputs. At the rear of the M3, the unique RGBlink modular platform becomes apparent, with a host of signal options and features.

Along with the on-board LCD monitoring, signature large tactile illuminated buttons feature with T-Bar mixing controls. Up to six outputs may be fitted to M3 for presentation solutions that go beyond just vision mixing, and with powerful scaling features, M3 is a fully integrated video system suitable for professional environments across entertainment to integration.

M3 is available in two variants with the M3e model having additional features for AUX outputs when fitted, including PIP capabilities and more.

# M3

Integrated vision mixer & scaler

12 mega pixel capacity

PST to PGM presentation switching

Dedicated background Inserts

Dual LCD displays built in

Genlock Y In

Support for Tally

## Genlock

Genlock Y in is included enabling synchronised operations of M3 across devices connected to a Genlock generator/source.

## Scale

Set output resolution independently from input resolutions, and scale the output pixel-to-pixel, ideal for direct connection to non-native displays such as LED. Arrange scaled layers is in any position.

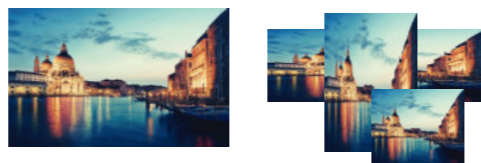

## Dual 2K Outputs

M3 is standard with two HDMI outputs. These outputs may be configured in a variety of ways – modes – included standard duplicated output, dual 2K (4Kx1K) or where AUX is fitted as spliced and extended.

## Auxiliary Outputs

With the optional AUX output module fitted, four 2K outputs are added to M3 (bringing the total to six 2K outputs). The AUX outputs are ideal for use a relay monitors, for distributed signals or spliced displays. With the M3s model, AUX outputs add PIP support.

## Multiview Preview

M3 features a dedicated multi-view preview display available both from the on board LCD and via a dedicated HDMI output. This configurable PVW can display up to eight input sources.

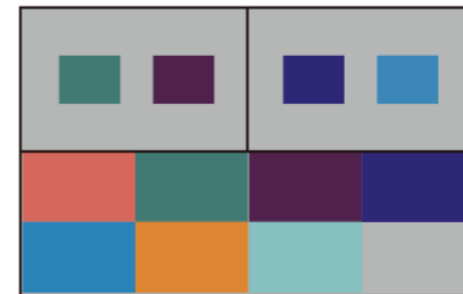

## PST/PGM Monitoring

An onboard LCD display is dedicated to providing monitoring of PST and may also be switched to show PGM. For external duplication of this monitoring, a dedicated HDMI output port is also provided.

## Modular Inputs

A wide range of input options are available with up to twelve inputs able to be user fitted. Input options include HDMI, DVI, SDI, DisplayPort, CVBS and USB 2.0 media.

## Presentation Mixing

Display and preview multiple video sources duplicated across outputs allowing main and relay display possibilities



## M3e Spliced 4K Presentation

With an AUX module fitted to an Me3 and an HDMI Loop, connect up to four displays to form a 4K display with PIPs and PST/PGM configuration



## Digital Effects

A video mask may be applied to a foreground PIP video layer. There are wide range of included masks, and in additional users may load custom masks for even more creative control. Other effects available include DSK/Chroma Key, blend edge softening effect and frames/borders including drop-shadow.

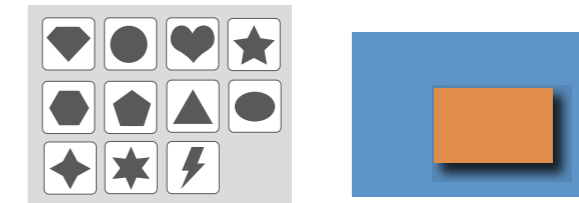

## Crop & Position

Select X and Y offsets along with width and height to select any image part for output.



## OSD

Import On Screen Display text messaging overlays in virtually any font or style, and either moving static. M3 provides a dedicated TAKE facility for OSD independently of the video TAKE.

## LOGO & STILL

Import and apply a STILL (watermark) or LOGO (channel transitions with TAKE), these layers are additional overlays regardless of video layers in use.

## Video Wall Presentations

Present to large video wall displays utilising up to 4K1K with multiple video layers with PST/PGM switching



## M3e Spliced Displays

With an AUX module fitted to an Me3, connect up to six displays to form a video wall of up to 8K1K



## STREAMING

- CAPTURE
- SWITCHER
- ENCODER
- CLOUD/DECODER
- ASK Series Collaboration solutions

## PRO AV

- D Series Digital Processors
- X Series Universal Processors
- M Series Mixing & Scaling
- FLEX Series Mixed Signal Matrix
- Q Series FLEX multi-signal matrix

## 1 Series

## T Series

## Subito Series

## UMS Series

## RMS Series

## MSP Series

## Accessories

## Software

## Reference

## Contact



# M2







## **Multi-layer video mixing and integrated solution**

Ideal for meeting and conference rooms, houses of worship and any events spaces where hands on video control is needed for one or more displays, M2 is a complete integrated video processing and control solution.

M2 is packed with advanced features across multiple operation modes that offer a high level of flexibility for live presentation applications.

Choose from two models – M2 with four HDMI outputs or M2s with additional duplicated two channel output via SDI and HDMI ideal for connecting downstream devices such as recording and streaming.

# M2

-  Integrated vision mixer & scaler
-  Four configurable 2K outputs
-  Up to modular inputs
-  Dedicated preview output
-  Genlock Y In
-  Tally Support
-  Choice of two models

## Group Mode

Both output channels are duplicated offering the same output as program and monitor. PIP's are available in this mode with PIP/layer count dependent on output resolution and layer arrangement.



## Output Splicing Modes

Split output across dual output channels for 4K x 1K split with PST, or across all four outputs for a videowall output of up to 8K x 1K.



## Digital Effects

A video mask may be applied to a foreground video layer. There are wide range of included masks, and in additional users may load custom masks for even more creative control. Other effects available include DSK/Chromakey and blend edge softening effect.



## Multiview Preview

M2 features a dedicated preview output via HDMI. This output presents a Multiview including preview of up to eight input sources.

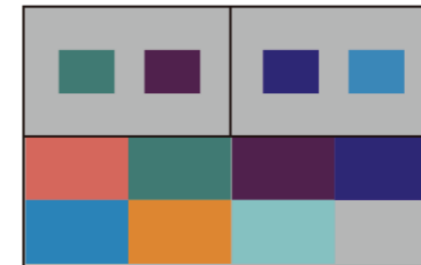

## Presentation Mixing

Display and preview multiple video sources with PIP fade-in fade-out over background layer.

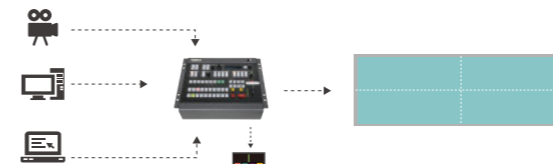

## Spliced 4K Presentation

Use all four outputs to form a 4K display fully synchronised and tear free.

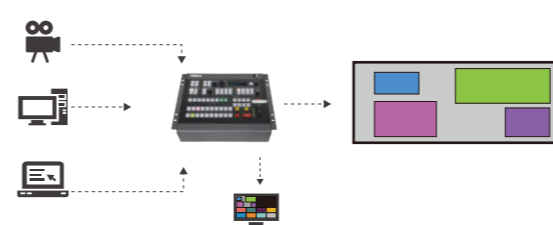

## Scale

Set output resolution independently from input resolutions, and scale the output pixel-to-pixel, ideal for direct connection to non-native displays such as LED. Arrange scaled layers in any position.

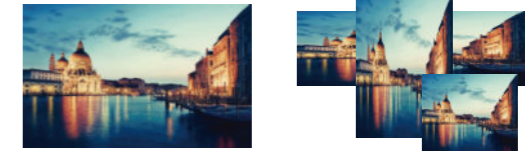

## Crop & Position

Select X and Y offsets along with width and height to select any image part for output.



## OSD

Import On Screen Display text messaging overlays in virtually any font or style, and either moving static. M2 provides a dedicated TAKE facility for OSD independently of the video TAKE.

## LOGO & STILL

Import and apply a STILL (watermark) or LOGO (channel transitions with TAKE), these layers are additional overlays regardless of video layers in use.

## Video Wall Presentations

Present to large video wall displays utilising up to 4K1K with multiple video layers with PST/PGM switching

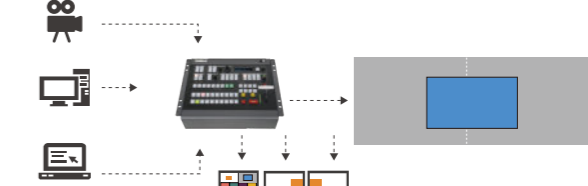

## Presentation Switching with Effects

Add a standard or custom mask to a PIP layer to enhance the presentation.

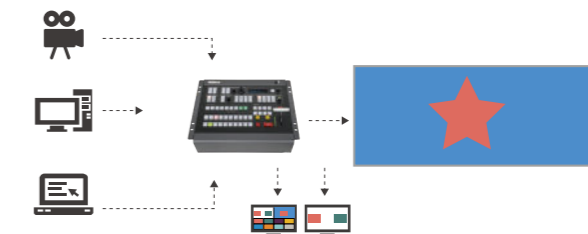

M2s

## STREAMING

- CAPTURE
- SWITCHER
- ENCODER
- CLOUD/DECODER
- ASK Series Collaboration solutions

## PRO AV

- D Series Digital Processors
- X Series Universal Processors
- M Series Mixing & Scaling
- FLEX Series Mixed Signal Matrix
- Q Series FLEX multi-signal matrix

## 1 Series

## T Series

## Subito Series

## UMS Series

## RMS Series

## MSP Series

## Accessories

## Software

## Reference

## Contact



# M1







## **Fully integrated video scaling and mixing for everyday**

A complete solution, simply connect M1 to any display and start presenting. Front panel console style controls together touch screen display make M1 intuitive and natural in use, even for the new operator.

More than just a video mixer, M1 allows full scaled output to modern displays without to additional equipment. For stage/conference presentations on board features including PIP (picture-in-picture) add powerful capabilities to make use of additional video sources including cameras.

While compact in size, M1 brings together essential features for small presentation environments, including audio mix features allowing connection to audio mixers or powered speakers.



-  Intuitive touch screen controls
-  Integrated vision mixer & scaler
-  Output options including HDMI & SDI
-  Dedicated preview output option
-  Genlock Y In
-  Tally Support
-  Wide range of input signal options

### Picture-in-Picture

Add a PIP as a foreground layer in any position, including with scale and crop.



### Digital Effects

The PIP may have an effect applied – options include masks (with a range built in as well as support for custom masks), DSK/Chroma Key to remove a background colour and variable edge blend, as soften effect to allowing the PIP to merged with the main image.



### Dedicated Preview

A dedicated HDMI output with multi-view is provided from which both PGM and PST can be monitored, along with input sources and audio levels.

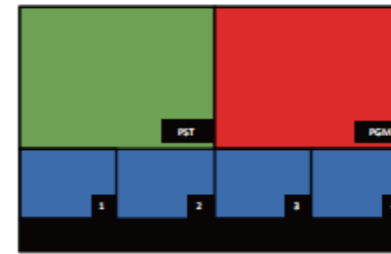

### Visual Enhancements

Apply a range of visual effects and enhancements with fine grain controls may be utilised for each input. Controls include brightness, contrast, saturation, sharpness and color temperature.



### Touch Screen Control

Access all the features of M1 easily and conveniently.

### Source Selection Keys

See the status of sources and select sources for PST from dedicated keys.

### Mixed Audio

Both embedded and insert audio are supported with separate left/right audio level controls available on the front panel. Audio may be selected independently from the video source. PPM monitoring maybe shown on the PVW as visual confirmation of source and output.

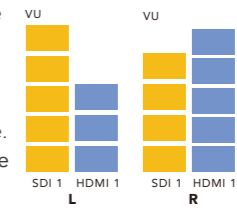

### Modular by Design

Each input is individual and are user fit – choose from a wide range of modular signal options. Modules are highly standardised across the RGBlink range for even greater flexibility.

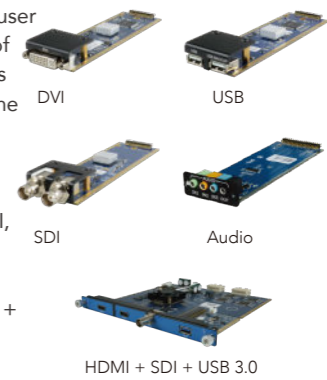

Input options include HDMI, DVI, SDI, CVBS, USB and more.

Output options are HDMI + SDI + USB 3.0

### Transition Effects

Transition between PST & PGM with cut, fade or transition via the T-bar or single touch controls.

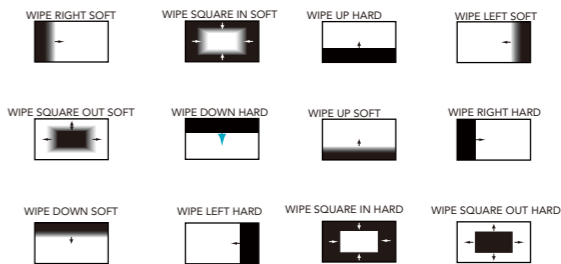

### Preset Banks

Store settings and recall presets with a single key press.

### Standard & Broadcast Models

Available in two model variants, the M1b model having audio bars on the Multiview and the preset buttons transformed as audio controls.



## STREAMING

- CAPTURE
- SWITCHER
- ENCODER
- CLOUD/DECODER
- ASK Series Collaboration solutions

## PRO AV

- D Series Digital Processors
- X Series Universal Processors
- M Series Mixing & Scaling
- FLEX Series Mixed Signal Matrix
- Q Series FLEX multi-signal matrix

- 1 Series Switcher/Scalers

- T Series Control Consoles

- Subito Series LED Control Solutions

- UMS Series Media Solutions

- RMS Series Monitoring Solutions

- MSP Series Video Tools/Extenders Signal Convertors Signal Distributors

- Accessories

- Software

- Reference

- Contact



**FLEX Series**  
Mixed Signal Matrix

# FLEXpro<sup>8</sup>

## Next generation flexible solution for sophisticated video applications

FLEXpro8 is an all new video processing solution for modern large scale display applications. With support for over 18 mega pixels across eight outputs, FLEXpro8 is designed for professional applications. Fit up to 16 independent inputs integrating a range of video sources and signals utilised in commercial display systems.

The innovative RGBlink modular signal system provides native on support for HDBaseT, Fiber and LED Control signals as well as conventional signals, embracing flexibility while being an efficient self-contained system.

Whether for integration or proAV FLEXpro8 has the multi-signal, multi-layer technology for virtually any display application.



### Modular Design

FLEXpro8 has 4 input slots which may be configured with up to 16 universal single modules or 8 dual height modules. Input support includes 4K@60 (HDMI2.0) as well as SDI, DVI, HDBaseT and USB2.0 Media. Modular outputs across 2 slots provides for 8 outputs, standard as DVI with options for SDI, HDMI, DVI, DisplayPort, HDBaseT and importantly native Subtío Quatro signals.

### HDR Support

Signals with High Dynamic Range are supported for processing via the processor with high bandwidth and wide gamut 12bit grey level processing.



### 18 Mega Pixel Capacity

Arrange outputs on a virtual canvas to create display surfaces up to 8192x2304px at high 60Hz digital refresh.

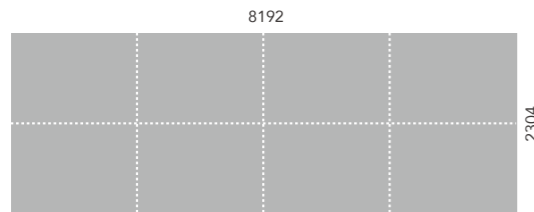

### Multi-Mode Operations

Select the operation mode suitable for the application from continuous video wall mode to presentation mode and routing modes.

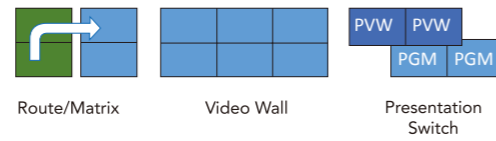

### Full Color Space

Video scaling and conversion takes advantage of the RGBlink full 4:4:4 in hardware processing engine for the maximum visual performance.

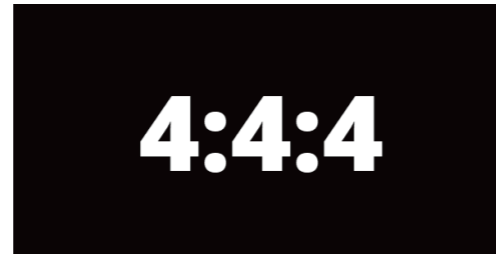

### Video Over IP

FLEXpro8 includes options for video over ethernet standards including HDBaseT modules allowing direct connection to displays without conversion.

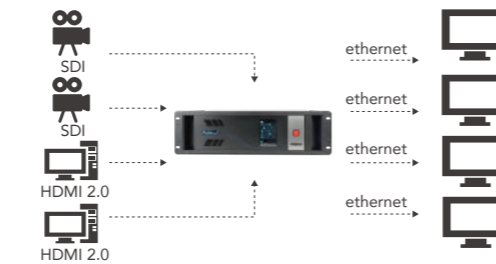

### 4K / UHD Support

Select from digital input and output options including HDMI.



### Genlock

For synchronisation with other video devices, Genlock Y In is provided along with loop out.



### Presentation Switch

Set FLEXpro8 in presentation mode to configure the outputs as for full preview (PST) and program (PST) operations with multiple layers across outputs. Seamlessly switch between presets.

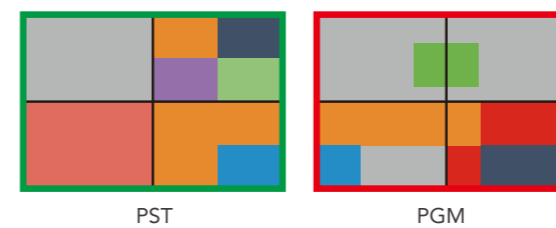

### 32 Video Layers

Display up to 32 video layers from across any of up to 16 input sources. A signal output supports up to eight layers allowing extensive multi-windowing opportunities

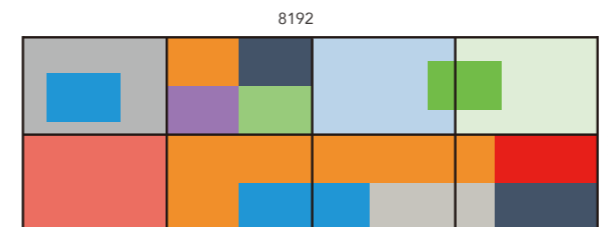

### Dedicated Multi-View Preview

A built in preview feature allows local and remote preview video sources. Connect display to HDMI PVW for a 4x4 Multiview. Connect the H.264 to XPOSE or a third party application to view multiple sources remotely. When connected to XPOSE, video can be seen in presets during configuration and operations.

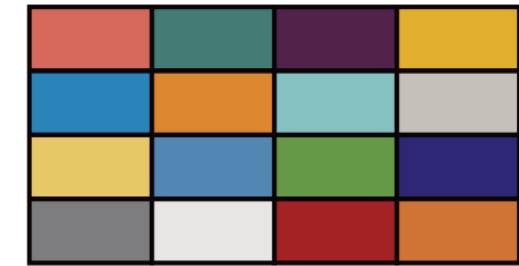

### Connect and Control

Remotely configure and control FLEXpro8 from XPOSE on Windows or macOS via LAN. Integrators may take advantage of RGBlink OpenAPI controlling FLEXpro8 from third party devices or applications over UDP.

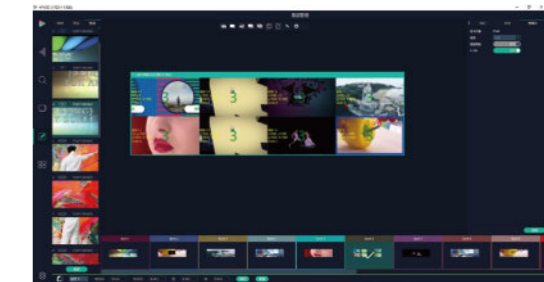

### Modular Power Supply

Fully self contained power supply is user exchangeable without tools. Power Supply is designed for high availability 24/7 server applications.



### Front LCD Monitoring

The integral LCD provides local monitoring and status of FLEXpro8.



### STREAMING

- CAPTURE
- SWITCHER
- ENCODER
- CLOUD/DECODER
- ASK Series Collaboration solutions

### PRO AV

- D Series Digital Processors
- X Series Universal Processors
- M Series Mixing & Scaling
- FLEX Series Mixed Signal Matrix
- Q Series FLEX multi-signal matrix

- 1 Series Switcher/Scalers
- T Series Control Consoles
- Subtío Series LED Control Solutions
- UMS Series Media Solutions
- RMS Series Monitoring Solutions
- MSP Series Video Tools/Extenders Signal Converters Signal Distributors

- Accessories
- Software
- Reference
- Contact

## LED Control System

With RGBlink Subito built directly in to FLEXpro 8, installing Subito Quatro provides deep and rich no-gap integration for LED displays natively into the video processing solution, enhancing efficiency and productivity with a single common interface while reducing potential points of failure and saving valuable rack space.

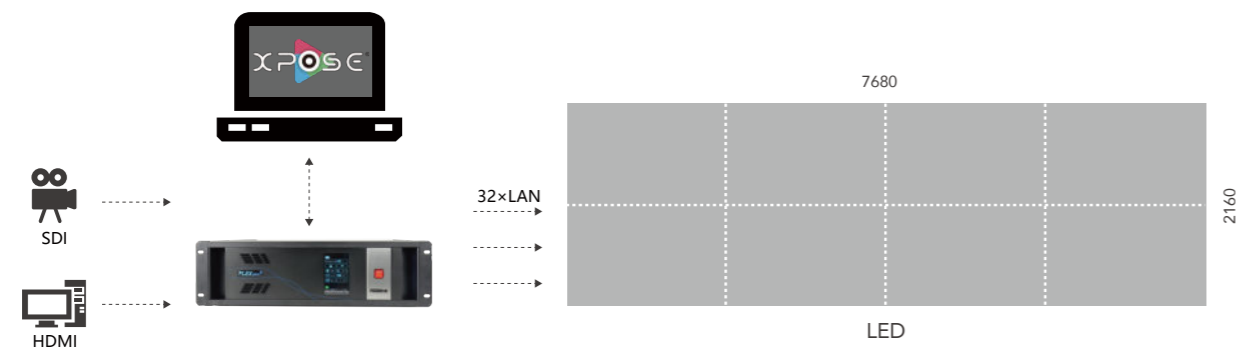

## Display System Management

Multi-display and multi-mode operations are available on FLEXpro 8, enabling the processor to provide a complete systems based solution across a combination of display types and operation requirements with centralised control.

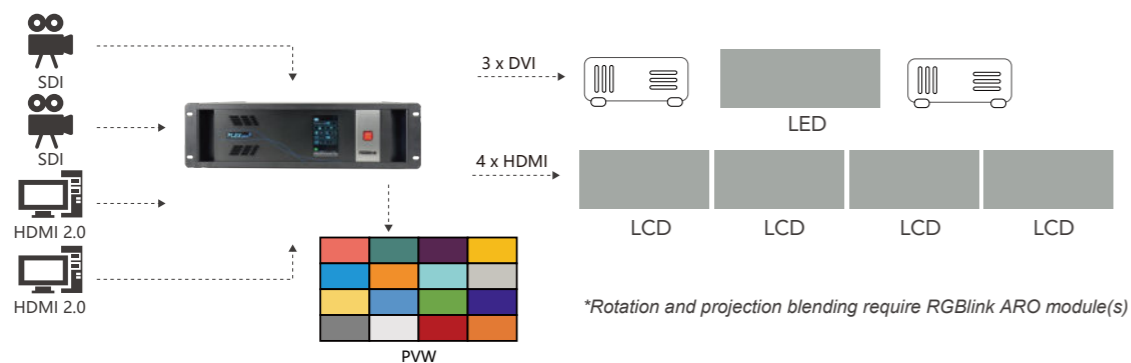

## Video Wall Processor

Configure FLEXpro8 as video wall splicing processor with up to 32 layers presented. Outputs may be arranged in pixel space as one of more displays with video mapped across the pixel space. Switch between presets seamlessly.

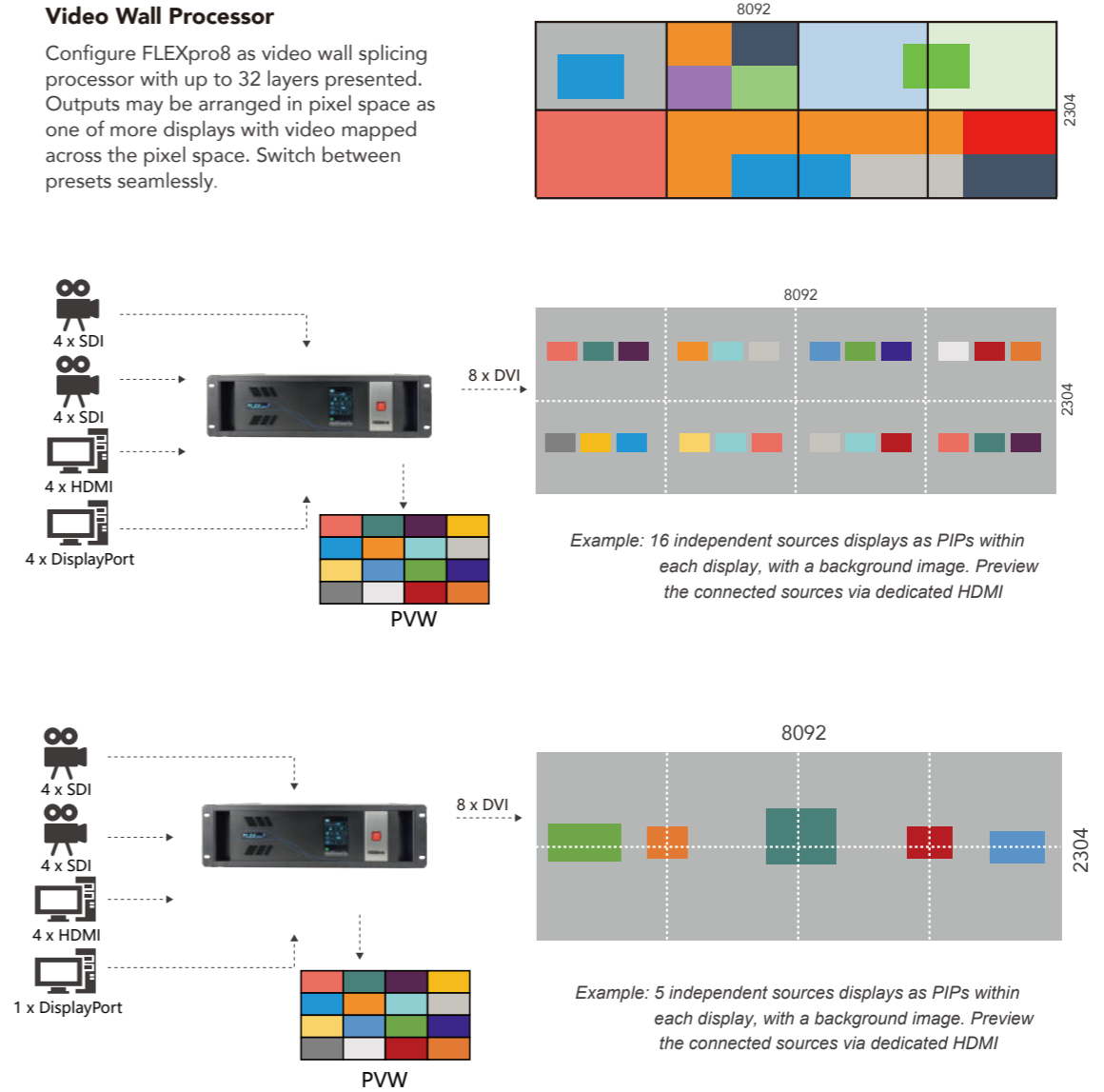

## Remote control

Control FLEXpro 8 via XPOSE, T1 Series consoles, or integrate via RGBlink OpenAPI with XPOSE and OpenAPI unlocking the powerful video control possibilities.

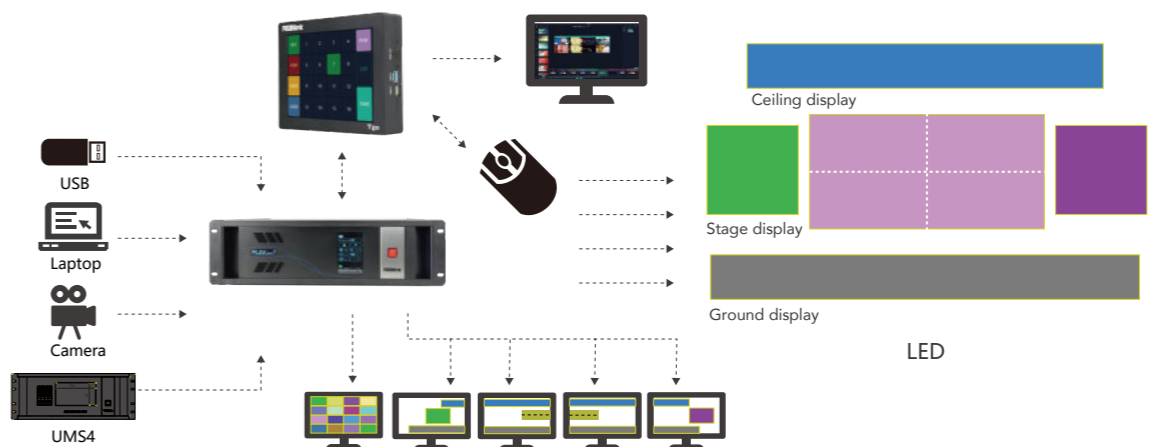

## STREAMING

- CAPTURE
- SWITCHER
- ENCODER
- CLOUD/DECODER
- ASK Series Collaboration solutions

## PRO AV

- D Series Digital Processors
- X Series Universal Processors

- M Series Mixing & Scaling

- FLEX Series Mixed Signal Matrix

- Q Series FLEX multi-signal matrix

- 1 Series Switcher/Scalers

- T Series Control Consoles

- Subito Series LED Control Solutions

- UMS Series Media Solutions

- RMS Series Monitoring Solutions

- MSP Series Video Tools/Extenders Signal Converters Signal Distributors

- Accessories

- Software

- Reference

- Contact

# FLEX RS1

## Creative Power - Advanced Rotation and Blending Processing.

For creative video display applications anywhere, RGBlink FLEX RS1 extends the possible. FLEX RS1 adds new levels of flexibility to hardware based video solutions. With multiple operation modes, the four FLEX RS1 outputs may be utilised for advanced rotation, blending and splicing from a choice of 4K inputs.

Each output is resolution independent. In rotation applications, each output can individually be rotated in single degree increments, positioned on a virtual canvas or pixel space with support for variable pixel densities.

As a blending processor for projection, variable edge blending is configurable to produce panoramic displays or arrays in any configuration.

For splicing applications – ideal for LED displays – FLEX RS1 is an easy to use compact processor for up to 8K x 1K.



### 4K Digital Input

FLEX RS1 features the RGBlink 4K60 digital input module for high resolution digital media sources to be connected via DisplayPort or HDMI. For rotation and blending applications, the 4K input provides for high quality visual signals to be used with minimum need for upscaling.



### RGBlink ARO™

Advanced Rotation and blending Output module features four DVI outputs with wide processing capability enabling sophisticated real time video display independent of source video.

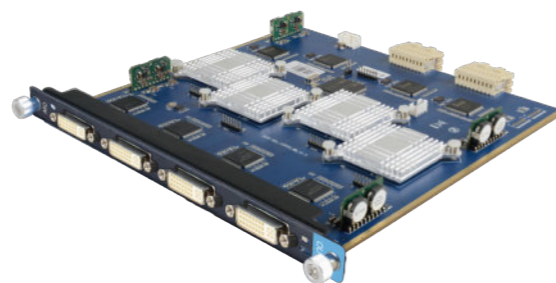

### Multi-Mode Operations

Suitable for a wide range of usage applications from installation to events, for creative rotation to blending and splicing, FLEX RS1 is a self-contained solution that simplifies advanced operations with a single device providing high level commonality across diverse applications.

### Independent Output Resolution

Each of the four outputs is resolution independent.

### Flip/Mirror

Outputs may be flipped in support of rear-projection applications or similar.

### Scale Crop & Position

Position displays on virtual canvas, select area of interest to set density and relative display size.

### ArtNet for Performance

FLEX RS1 has ArtNet built in, with an extensive DM512 control profile, RS1 may be dynamically controlled from DMX show controllers allowing for real-time animation applications.



### Integrate with OpenAPI

Control FLEX RS1 remotely from third party devices and applications with RGBlink OpenAPI UDP command set.

### Familiar XPOSE Configuration

FLEX RS1 may be connected via Ethernet to a computer running XPOSE for control and configuration within the RGBlink universal application platform. The intuitive visual interface templates and interacts with FLEX RS1 for full control and configuration.

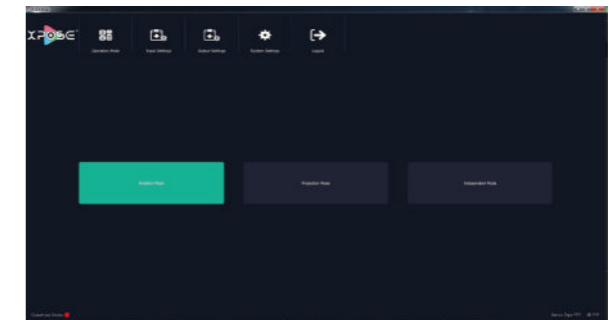
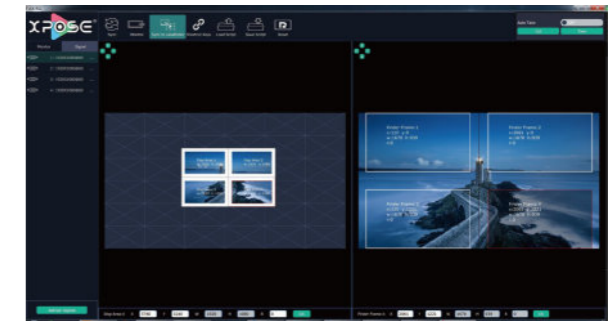
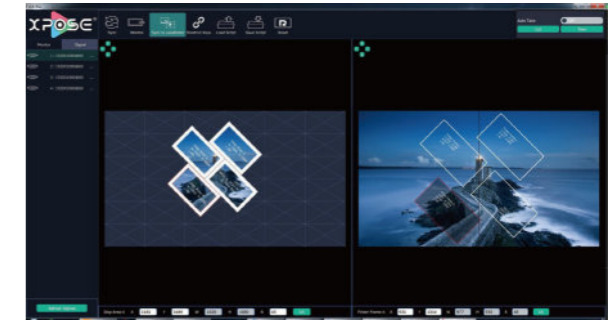
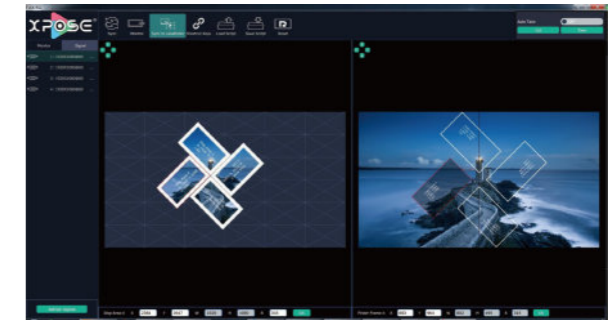

### STREAMING

CAPTURE

SWITCHER

ENCODER

CLOUD/DECODER

ASK Series  
Collaboration solutions

### PRO AV

D Series  
Digital Processors

X Series  
Universal Processors

M Series  
Mixing & Scaling

FLEX Series  
Mixed Signal Matrix

Q Series  
FLEX multi-signal matrix

1 Series  
Switcher/Scalers

T Series  
Control Consoles

Subito Series  
LED Control Solutions

UMS Series  
Media Solutions

RMS Series  
Monitoring Solutions

MSP Series  
Video Tools/Extenders  
Signal Converters  
Signal Distributors

Accessories

Software

Reference

Contact

### Variable Edge Blending

As an edge blending processor, FLEX RS1 may be configured to output video enabling up to four projectors to be arranged combined to form a single display surface. Area of interest is also selectable allowing variable projection distances and non-linear overlaps.

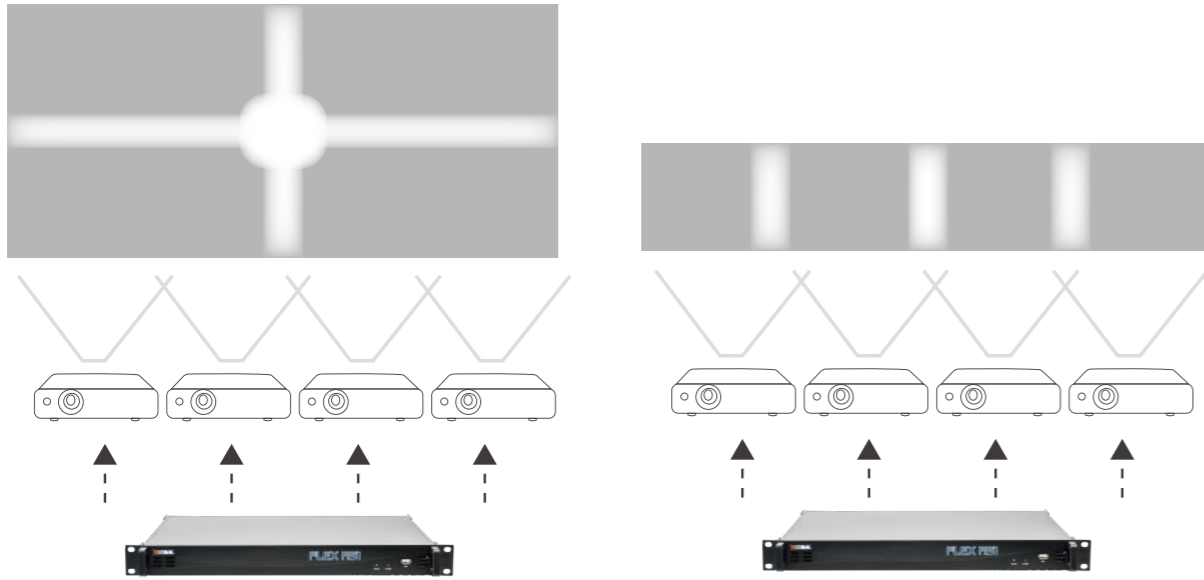

### 4K Video Wall Splicing

Adding to the versatility of FLEX RS1 is the facility to use the processor as a 4K video wall controller with outputs able to be configured independently for a range of display possibilities.

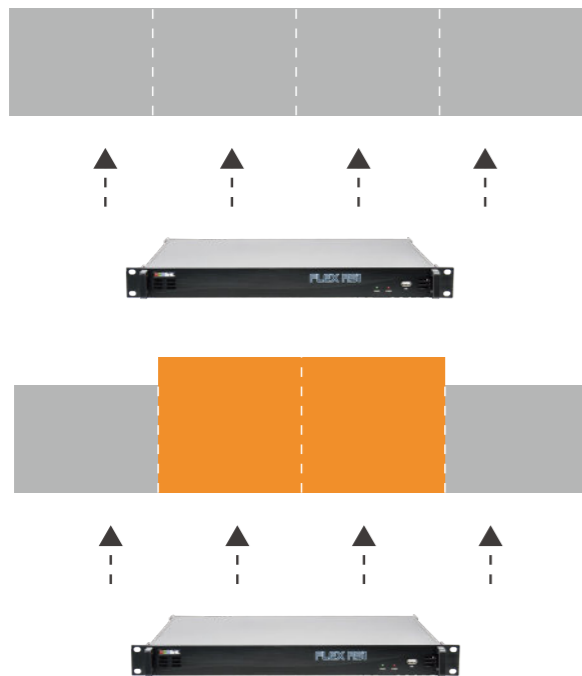

### Matrix Routing

Take advantage of all four inputs, routing scaling/converting to each of the four DVI outputs. Each output has independent resolution.

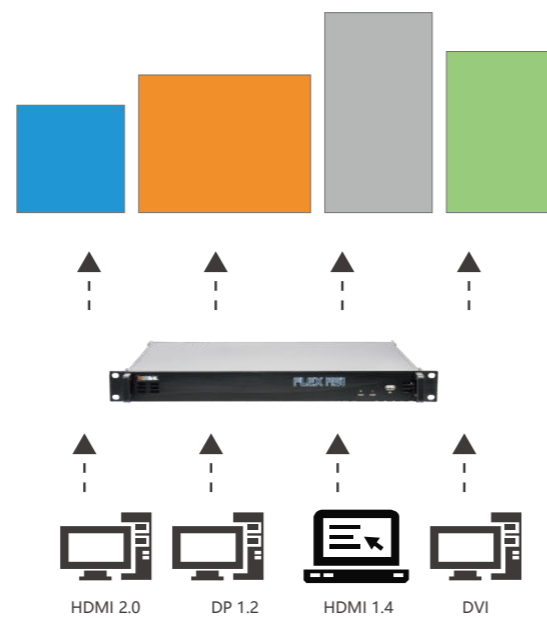

### Advanced Rotation

FLEX RS1 enables displays to be physically positioned and rotated in fine single degree increments, with the processor mapping and delivering video content to the display surface based on position in pixel space. Variable density allows displays of varying sizes to be combined to form creative video display solutions.

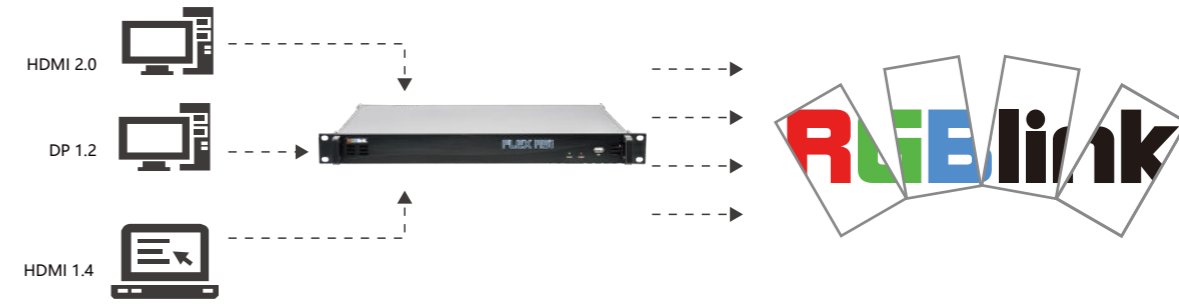

Each of the four outputs may be configured individually with rotation in 1 degree positioning. Video layered and mapped across the output displays.

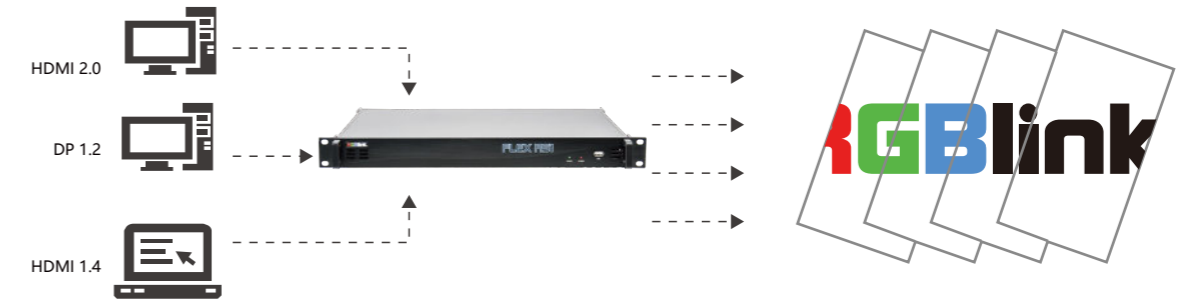

Overlapping displays are supported in any arrangement, opening up a wide range of application possibilities.

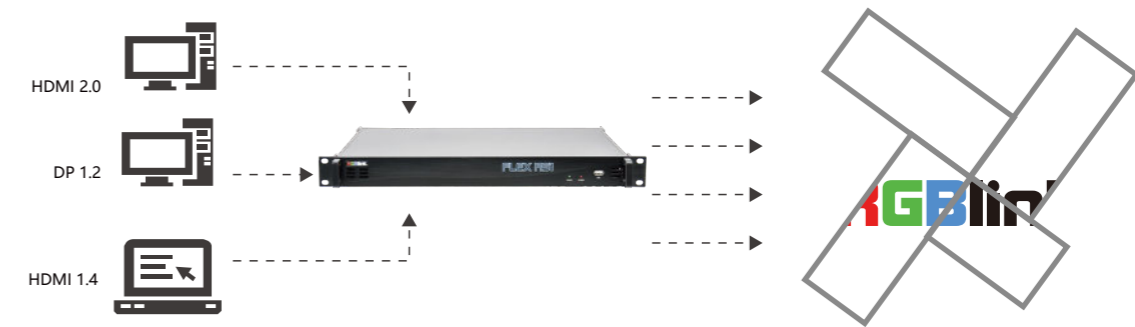

Each output can be configured independently allowing displays of multiple sizes and pixel densities to be supported.



### STREAMING

- CAPTURE
- SWITCHER
- ENCODER
- CLOUD/DECODER
- ASK Series Collaboration solutions

### PRO AV

- D Series Digital Processors
- X Series Universal Processors
- M Series Mixing & Scaling
- FLEX Series Mixed Signal Matrix
- Q Series FLEX multi-signal matrix

### 1 Series Switcher/Scalers

### T Series Control Consoles

### Subito Series LED Control Solutions

### UMS Series Media Solutions

### RMS Series Monitoring Solutions

### MSP Series Video Tools/Extenders Signal Convertors Signal Distributors

### Accessories

### Software

### Reference

### Contact

# FLEX 4ML

## 4K videowall splicing solution

With up to eight inputs including a 4K@60 module fitted as standard, FLEX4ml offers a wide range of input source options which can be switched on demand to the output displays either as the main program output or as PIP's. Four independent 2K outputs are provided along with optionally duplicated outputs for each. Ideal for commercial display applications, FLEX4ml is much more than video splicing for video walls, with multi-layer technology providing a resource up to eight video layers all with all sources, synchronised for output.



### 4K as Standard

Fitted standard with a 4K input module, FLEX4ml features signal support for HDMI 2.0, DisplayPort 1.2 and Dual Link DVI.

### Expandable Input Support

FLEX4ml has a modular design allowing the additional of up to another four input signals selectable from the wide range of native signal options for increased flexibility and resilience.

### 4K 2K Splicing

Seamlessly splice 4K@60 signals to multiple 2K outputs fully synchronised and pixel perfect.

### Dynamic Multi-Layer Splicing

Arrange layers across outputs, select from built-in presets or customise as needed.

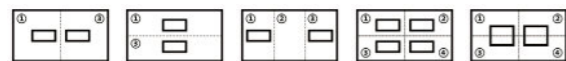

### Duplicated Outputs

Each of the four DVI outputs maybe optionally supported with a duplicated redundant output which may be used for loop back, backup or area of interest configurations.



### Flexible Operations

FLEX4ml provides multiple operation modes including 4K2K, 8K1K and 4K1K Splicing, Presentation and Switch modes. Devices may be deployed in a variety of ways allowing a high level of hardware and operational consistency.

### Switch Seamlessly

Recall and switch between presets on demand or on a schedule with jitter free seamless switching regardless of sources selected.

### Powerful Configuration & Control

Configure and control FLEX 4ml from XPOSE® - the rich UI desktop platform for Windows and macOS. Control FLEX 4ml over Ethernet with either XPOSE or RGBlink OpenAPI which provides extensive integration opportunities with virtually any 3rd party control.

### Genlock Y

Genlock Y (Blackburst) input and loop facilities are provided allowing FLEX4ml to be synchronised with other video devices in conjunction with a Genlock Generator.

### Videowall Splicing

Use FLEX4ml splicing mode operations to configure continuous videowall displays in a variety of ways with single or multiple video sources.

### 4K2K Splicing

Input a 4K source via DisplayPort or HDMI with output split and spliced to the four outputs pixel-topixel and with bezel offset support. Overlay windows or PIPs can be applied with up to 8 layers total across the displays including the main source.

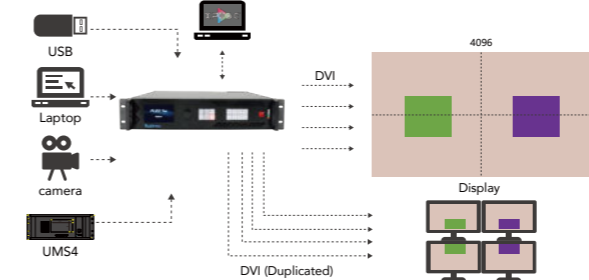

### 8K1K splicing

Input a 4K1K source via DisplayPort, HDMI or DVI with output scaled, split and spliced to the four outputs to create a 8K wide display. Use up to four PIP layers.

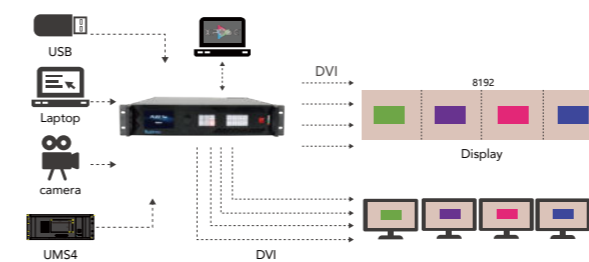

### Dual 4K1K Splicing

Input a 4K1K source via DisplayPort, HDMI or DVI with output split and spliced to each pair of two with up a PIP layer available for each output.

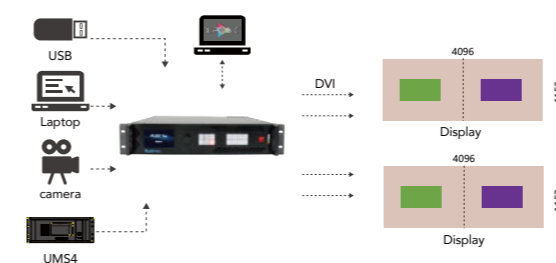

### Presentation Switching

Use multiple video layers on a 2K output and background with fade-in-fade out of windows/PIPs.



Product shown with optional modules fitted. Refer Specifications and Guides for more information.

### 2K Presentation

Up to in total of 8 layers may be used on a single 2K DVI output display. With a dedicated background layer from one of the input (One 4K input or 2 separately 2K inputs to be used for this live input), or saved background picture, the operator can add up to 7 layers on the top of the background, in different presets.

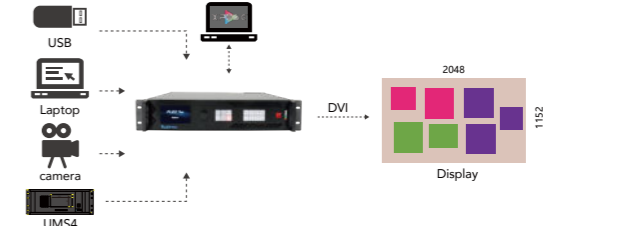

### 4K1K Presentation

Up to in total of 8 layers may be used on two 2K DVI outputs display. With a dedicated background layer from one of the input (One 4K input or 2 separately 2K inputs to be used for this live input), or saved background picture, the operator can add up to 3 layers on the top of each 2K output, in different presets.

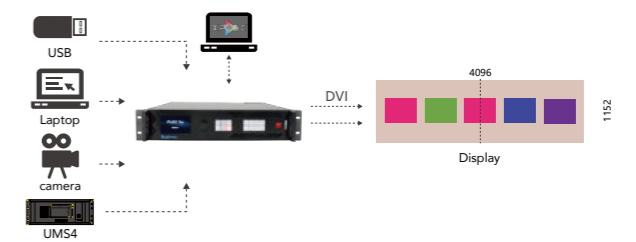

### 12K Presentation

Up to in total of 8 layers may be used on three 2K DVI outputs display. With a dedicated background layer from one of the input (One 4K input or 2 separately 2K inputs to be used for this live input), or saved background picture, the operator can add up max 2 layers on the top of each 2K output, in different presets.

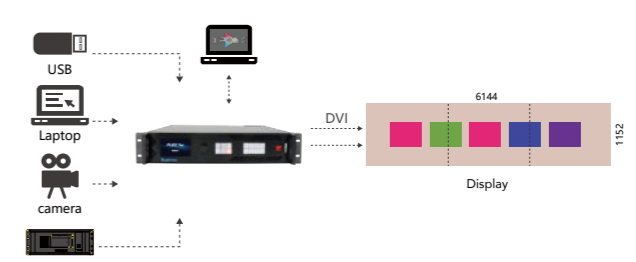

### 16K Presentation

Up to in total of 8 layers may be used on three 2K DVI outputs display. With a dedicated background layer from one of the input (One 4K input or 2 separately 2K inputs to be used for this live input), or saved background picture, the operator can add 1 layers on the top of each 2K output, in different presets.

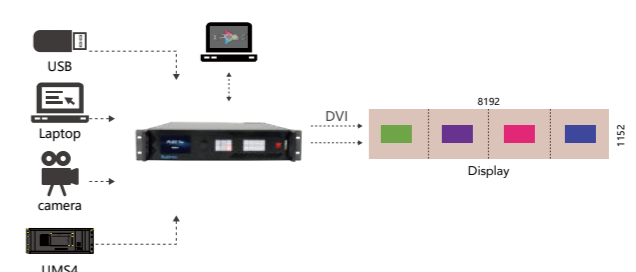

## STREAMING

- CAPTURE
- SWITCHER
- ENCODER
- CLOUD/DECODER
- ASK Series Collaboration solutions

## PRO AV

- D Series Digital Processors
- X Series Universal Processors
- M Series Mixing & Scaling
- FLEX Series Mixed Signal Matrix

## Q Series

- FLEX multi-signal matrix

## 1 Series

- Switcher/Scalers

## T Series

- Control Consoles

## Subito Series

- LED Control Solutions

## UMS Series

- Media Solutions

## RMS Series

- Monitoring Solutions

## MSP Series

- Video Tools/Extenders
- Signal Convertors
- Signal Distributors

## Accessories

## Software

## Reference

## Contact

# FLEX

## FLEX 16



### 16x16 Mixed Signal Matrix & Videowall Processor

Just 2U, FLEX16 supported up to 16 inputs and outputs which may be selected from a wide range of signal options. Install the Splicing EXT slot interface in place of a Matrix EXT slot interface to achieve spliced videowall output. FLEX 16 is standard with removable front panel keyboard and OLED display for local matrix operations, there is an optional a blank panel for splicing or unattended applications.

### 32x32 Mixed Signal Matrix & Videowall Processor

Install up to 32 inputs and outputs. With no requirement to fill all slots FLEX32 can be configured precisely for specific applications from the wide range of signal options available. Installing one of more Splicing EXT slot interfaces in place of a Matrix EXT slot interfaces to achieve spliced videowall output in combination with matrix operations for a compact and efficient video distribution and display system. FLEX 32 is standard with front panel keyboard and OLED display for local matrix operations, with a blank panel able to be installed for matrix and applications using remote control.

#### Matrix

One-to-one or one-to-many with signal cross conversion



#### Videowall

Input signal spliced across output videowall display

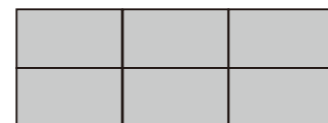

### Fully Modular Design

Input and output modules across the FLEX series are common and include a wide range of signal options that can be mixed-and-matched to requirement, reducing the need for external convertors, reducing points of failure and reducing complexity, saving space and enhancing performance.

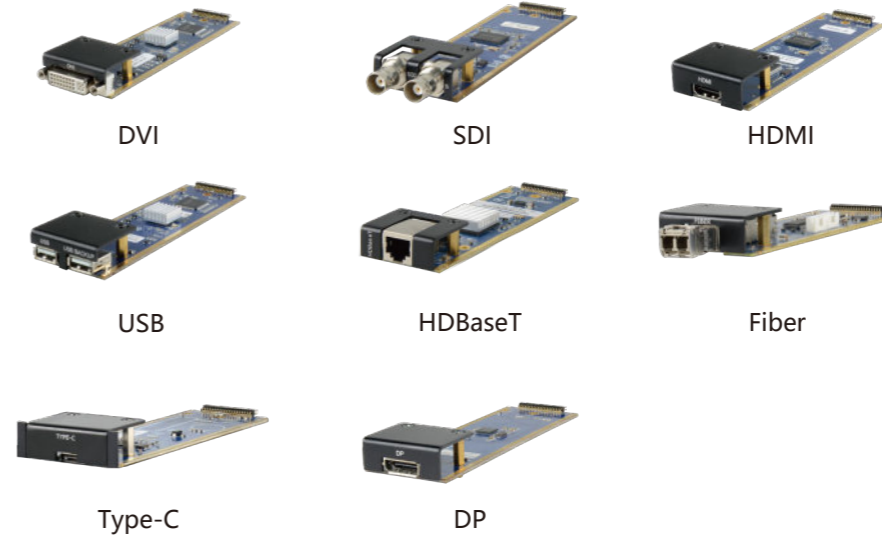

### Matrix Operations

As hybrid mixed-signal matrix, FLEX supports any-in-any-out signal switching as one-to-many, many-to-many and many-to-one. FLEX products provide a simple user focussed structure that maximises flexibility and allows installation with the overhead of unutilised signals.

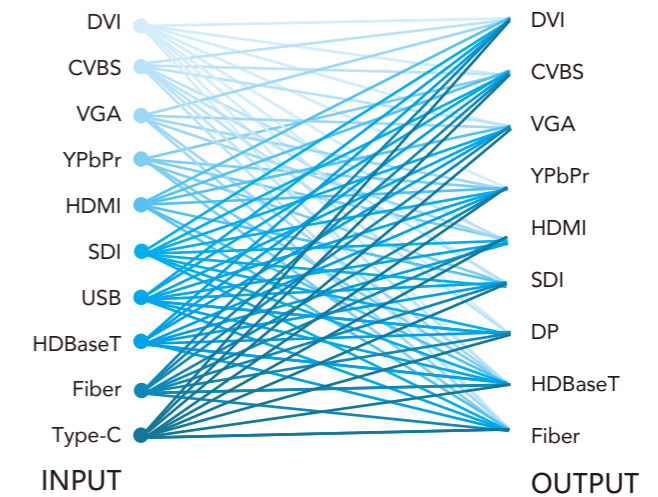

### STREAMING

- CAPTURE
- SWITCHER
- ENCODER
- CLOUD/DECODER
- ASK Series Collaboration solutions

### PRO AV

- D Series Digital Processors
- X Series Universal Processors
- M Series Mixing & Scaling
- FLEX Series Mixed Signal Matrix

### Q Series FLEX multi-signal matrix

- 1 Series Switcher/Scalers
- T Series Control Consoles
- Subito Series LED Control Solutions
- UMS Series Media Solutions
- RMS Series Monitoring Solutions
- MSP Series Video Tools/Extenders Signal Convertors Signal Distributors

- Accessories
- Software
- Reference
- Contact



**Q Series**  
FLEX multi-signal matrix



# Q16pro

## Multi-Window splicing processor for LCD & LED Videowall

Proven LCD videowall technology has never been more affordable and accessible with Q Series solutions to provide the essential connectivity and processing between video connect and videowall display. Available in 16 output models, Q Series processors are ideal for applications across commercial, retail, security and more. Tailored for connectivity LCD displays, Q16 reduce complexity of managing and supporting these displays. In applications such as security where extensive multi-window display is required, Q Series solutions offer even more power performance. With a modular design, Q Series frames can be fitted with signals of choice for particular applications.

Q16pro adopts a high-performance video image processing system with a pure hardware wire-speed processing architecture, which is suitable for education and scientific research, government announcements, information publishing, administrative management, military command, exhibitions, security monitoring, commercial sales and other industries. The modular input and output card structure is adopted, and the arbitrary mixing function of the input card is realized at the same time. Not only can it easily access the common HDMI/DVI/VGA/YPbPr/CVBS and other multiple signals, but also support DP1.2, HDMI2.0 and other ultra-high resolution 4K/8K signal input and output, easily realize 4K multi-screen point-to-point splicing. Designed for LEDs, it can flexibly realize unconventional resolution customization, especially optimized for non-standard signals, with strong customization capabilities, and realize flexible window roaming, picture zoom and other functions.



#### 4 ~ 26U models optional

Q16pro has 4~26U chassis options, and adopts a hybrid output card slot design, which greatly increases the user's flexible and changeable choices, and can support up to 160 inputs and 160 outputs at the same time.

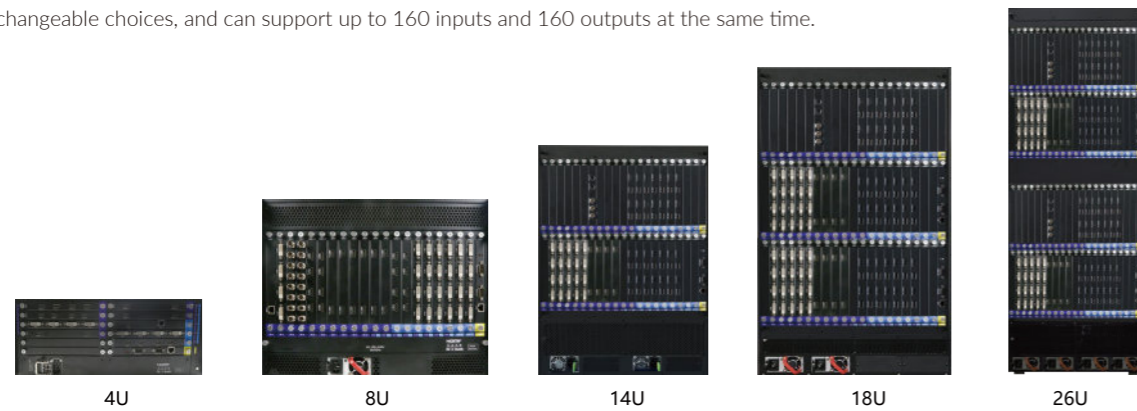

#### Streaming echo

The PVW preview card has an RJ45 echo network port and an HDMI output monitoring. The XPOSE visualization software interface can realize input source preview and output echo. The HDMI output can be connected to the monitor and can preview up to 64 inputs to meet the real-time display needs of customers.

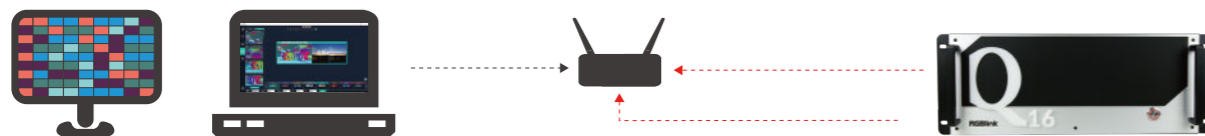

#### OSD rolling subtitles

Support static and dynamic OSD subtitles. You can modify the subtitle font, character size, color and subtitle background color.

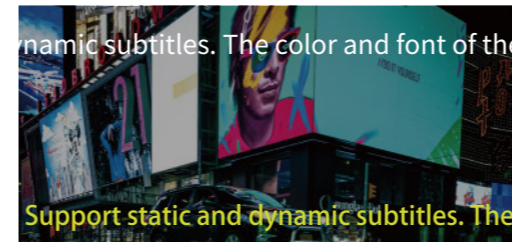

#### 3D stitching

Supports left and right eye 3D stitching mode, 120HZ input and output 3D stitching mode internally locks frame synchronization, 3D segmentation and fusion are completely seamless. One-key switching of scenes between 2D mode and 3D mode is realized through software.



#### Layer overlay, zoom, roam

Layer is the soul of the video splicer. Q16pro uses the latest FPGA algorithm to cross output ports without occupying layers. A single port can support up to 8 screens at the same time. At the same time, each layer has arbitrary zoom and arbitrary roaming functions, giving customers full freedom. It also supports the partial cropping function, which makes it easy to capture the partial screen.

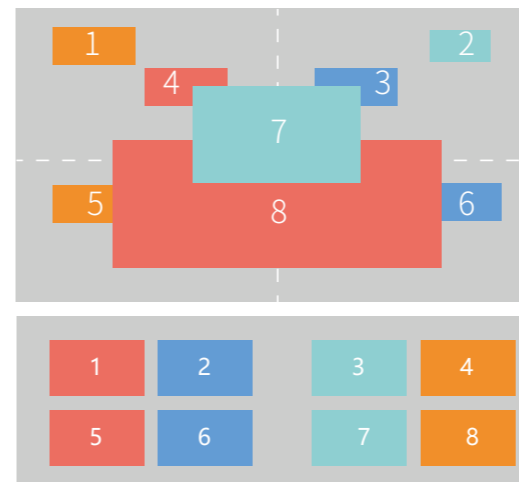

#### 4K UHD

Supports input and output modules that support 4K signals such as HDMI2.0, DP 1.2, HDMI 1.4, DVI, etc., and EDID can be edited. In the 4K era, it is natural to have a larger display resolution and a more shocking display effect.



#### Output custom resolution

Single-port output supports 2.5 million pixel customization, and the maximum width or height within the range of 2.5 million pixels can support 3840 pixels, making it easier for users to control the loading scheme.

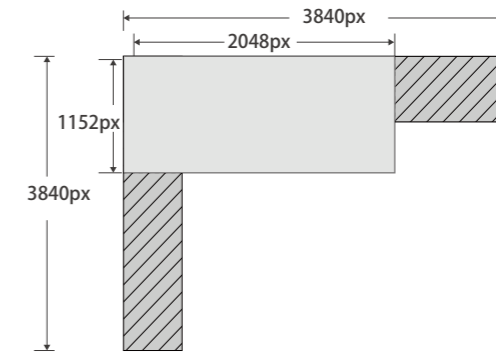

#### 0-360 degree arbitrary rotation stitching

Support arbitrary angle (0-360) rotation and arbitrary dot pitch creative splicing. Support mixed splicing of large and small screens, support mixed splicing of LED/LCD/projection.



#### STREAMING

- CAPTURE
- SWITCHER
- ENCODER
- CLOUD/DECODER
- ASK Series Collaboration solutions

#### PRO AV

- D Series Digital Processors
- X Series Universal Processors
- M Series Mixing & Scaling
- FLEX Series Mixed Signal Matrix
- Q Series FLEX multi-signal matrix
- 1 Series Switcher/Scalers

- T Series Control Consoles

- Subito Series LED Control Solutions

- UMS Series Media Solutions

- RMS Series Monitoring Solutions

- MSP Series Video Tools/Extenders Signal Convertors Signal Distributors

- Accessories

- Software

- Reference

- Contact

# Product solutions

## A splice input multiple-output amplifying



## 4K multi-input multi-output point-to-point splicing

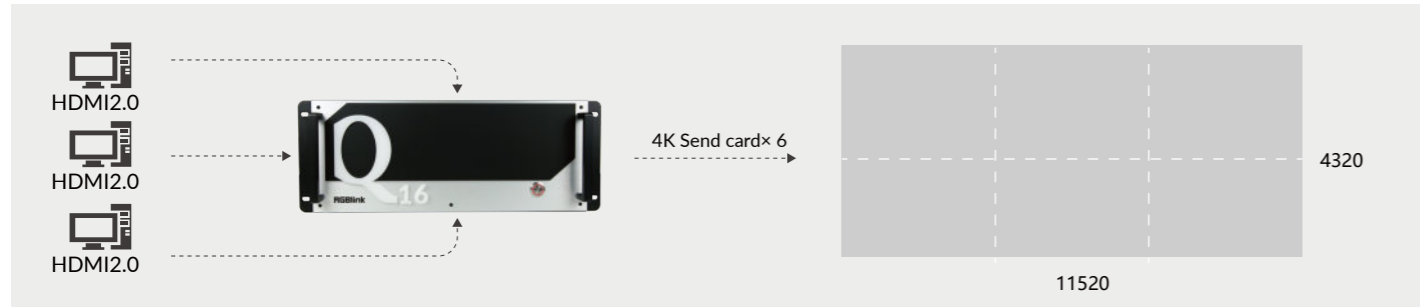

## Multi-picture + splicing display

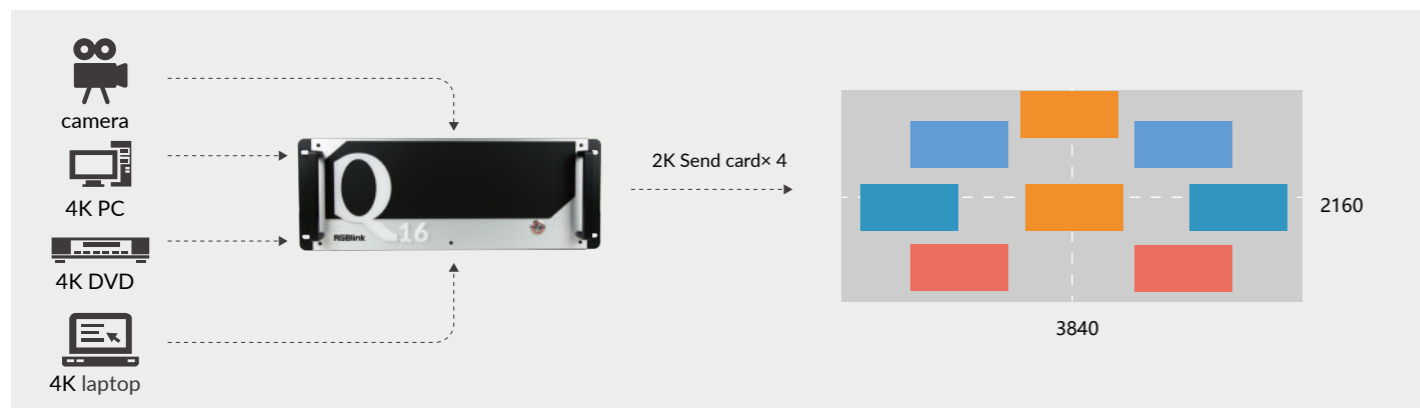

## Independent display, while a plurality of tape carrier LED, LCD, projection screen

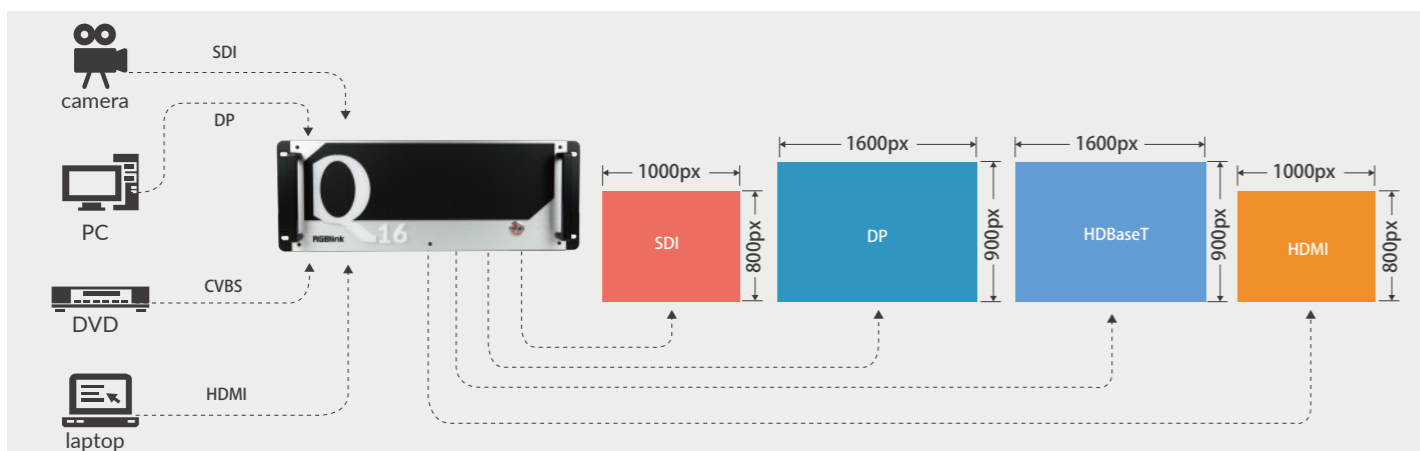

## Audio and video synchronization switching

Supports embedded audio and external audio input, audio output and video output can be switched synchronously according to different scenes.

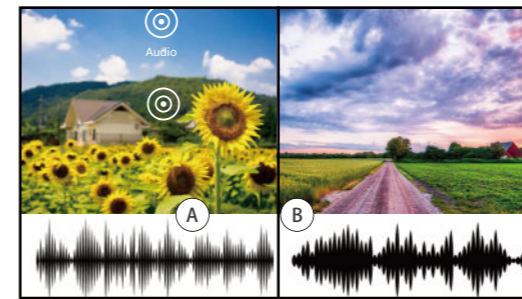

## XPOSE 2.0 control

The main body of the RGBlink software ecosystem. Scene editing, modification, preset switching, system settings, interface configuration, user authority management and other functions. Communicate with equipment via TCP/IP and RS232.



## Full range of interfaces and mixed card slot function

With the mature standard interface form on the market, customers can easily combine input and output modules. The output card slot supports input mixed insertion, which is simple and flexible, and adapts to various flexible site changes of customers.

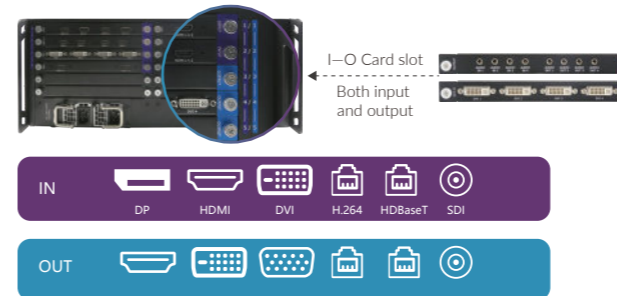

## STREAMING

- CAPTURE
- SWITCHER
- ENCODER
- CLOUD/DECODER
- ASK Series Collaboration solutions

## PRO AV

- D Series Digital Processors
- X Series Universal Processors
- M Series Mixing & Scaling
- FLEX Series Mixed Signal Matrix
- Q Series FLEX multi-signal matrix

- 1 Series Switcher/Scalers

- T Series Control Consoles

- Subito Series LED Control Solutions

- UMS Series Media Solutions

- RMS Series Monitoring Solutions

- MSP Series Video Tools/Extenders Signal Converters Signal Distributors

- Accessories

- Software

- Reference

- Contact



**1 Series**  
Switcher/Scalers

# X1PRO E

## Essential 4K Video Scaling and Splicing

Take advantage of 4K video sources to scale and splice to multiple 2K outputs. Compact in form at only 1U, switch between multiple sources glitch free with ease. Spliced outputs may be arranged in a variety of ways in addition to conventional 4K split, with panoramic and other configurations. X1pro e also offers multiple operation modes to support applications such as 4K1K and more.



### Standard 4K Inputs

X1pro e includes popular DVI and DisplayPort inputs supporting 4K, with the DVI2 also supporting HDMI (and HDCP). Loop connectors are provided allowing connectivity to other devices.

### 4K Split Outputs

With standard output to quad DVI connectors, X1pro e is ready to connect to common LED systems, facilitating pixel-to-pixel splicing across multiple outputs and displays regardless of physical arrangement.

# 4K

### Multi-Mode Operations

Ideal for a range usage applications, X1pro e is ready with the flexibility of multiple operation modes, enabling display solutions from conventional 2K with presentation modes, through to 8Kx1K splicing

### Add Additional Inputs

The unique RGBlink modular input system is available on board X1pro e, allowing users to add up to an additional three 2K input sources for added flexibility. Options include USB2.0, 3G-SDI and more.

### Configurable Splicing

Output splicing may be configured in a variety of ways to deliver a continuous display surface using the four DVI outputs provided, whether in conventional formats or custom formats.

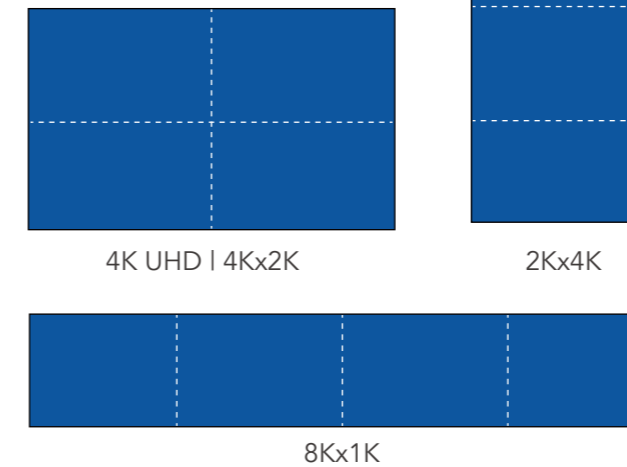

### Seamless Switching

In preview mode, outputs are divided between Preview (PVW) and Program (PGM) functions, with the PVW allowing operators to visually confirm source/preset video before TAKE to output.

In standard splicing modes where all four outputs are utilised for the main Program display, no preview is available, nonetheless switching between sources is seamless.

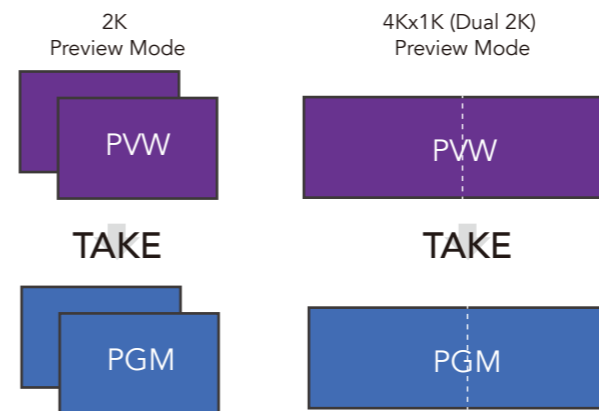

### Redundant Outputs

X1pro e includes a full set of backup/loop outputs, fully synchronised with the main outputs, these outputs may be utilised to supply video to backup displays or LED control systems, increasing the availability options without the need for additional splitters.



### Robust & Flexible

Signal failure over, or Hot backup is available. In the event a source signal is lost, the X1pro e can automatically switch to the alternate source specified.

### Direct Access

Configure and control X1pro e directly from the front panel. With large illuminated buttons and OLED display, X1pro e operations are intuitive and fast.

### LOGO Capture

Capture a video frame and store on board X1pro e, ideal for logos, default or fail-over messages.

### Test Patterns

In aid of configuration, X1pro e includes common test patterns.

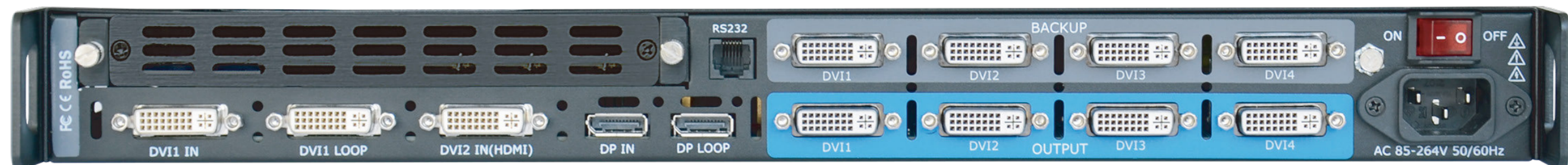
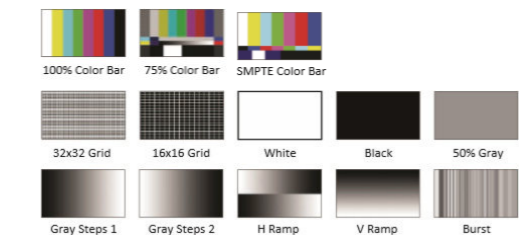

\* shown with optional modules fitted as example configuration. Refer to Specifications and Guides

## STREAMING

- CAPTURE
- SWITCHER
- ENCODER
- CLOUD/DECODER
- ASK Series Collaboration solutions

## PRO AV

- D Series Digital Processors
- X Series Universal Processors
- M Series Mixing & Scaling
- FLEX Series Mixed Signal Matrix
- Q Series FLEX multi-signal matrix

## 1 Series Switcher/Scalers

## T Series Control Consoles

## Subito Series LED Control Solutions

## UMS Series Media Solutions

## RMS Series Monitoring Solutions

## MSP Series Video Tools/Extenders Signal Converters Signal Distributors

## Accessories

## Software

## Reference

## Contact

### 2K Preview/Switcher Mode

In Preview mode, outputs are divided into 2K duplicate pairs, with two ports as preview (PST) and two ports as program (PGM). Switch seamlessly from PST to the PGM outputs.

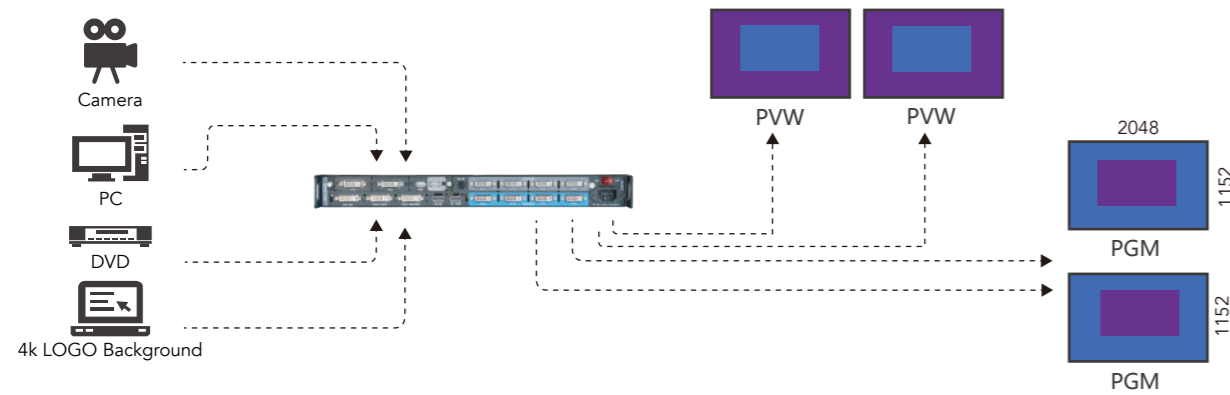

### 4K Split Mode

Use a 4K/UHD input signal with X1pro e to easily split and distribute across multiple 2K outputs, ideal to produce native 4K video wall solutions.

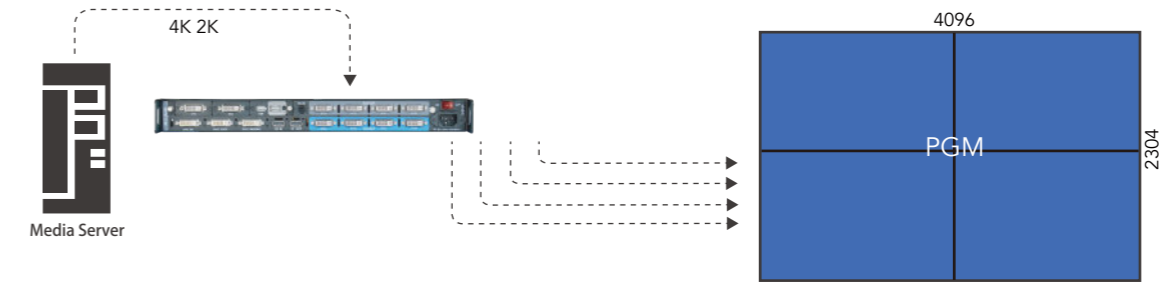

### 4K1K Preview/Switcher Mode

In this seamless switcher mode, outputs are arranged in pairs, with two ports in split modes providing a 4K by 1K preview (PVW) and the other two DVI ports similar as program (PGM) outputting 4K by 1K to be a single seamless display. Alpha cross fade between PVW and PGM via the TAKE button.

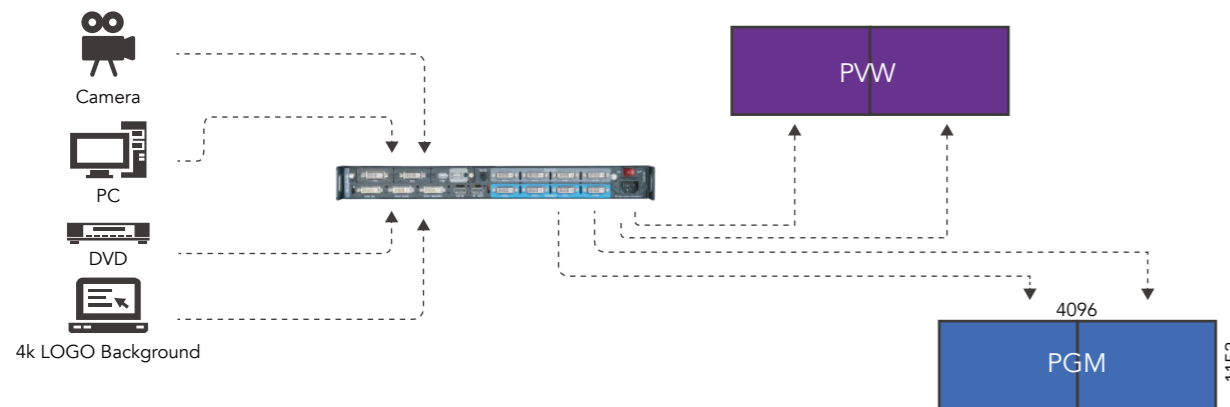

### 8K1K Split Mode

Take one or more video sources to produce a panoramic style 8K x 1K display seamlessly spliced and synchronised for continuous display. Suitable for stage and studio display applications.

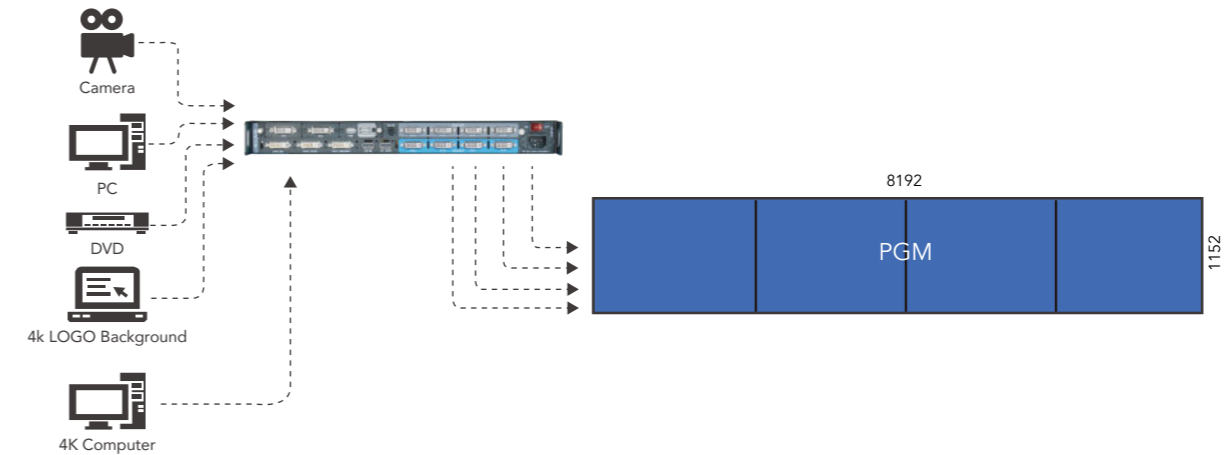

### 4K1K Split Mode

Each pair of outputs forms a duplicated 4K1K display with a background layer across the 4k1K and a PIP able to be added to each 2K1K area.

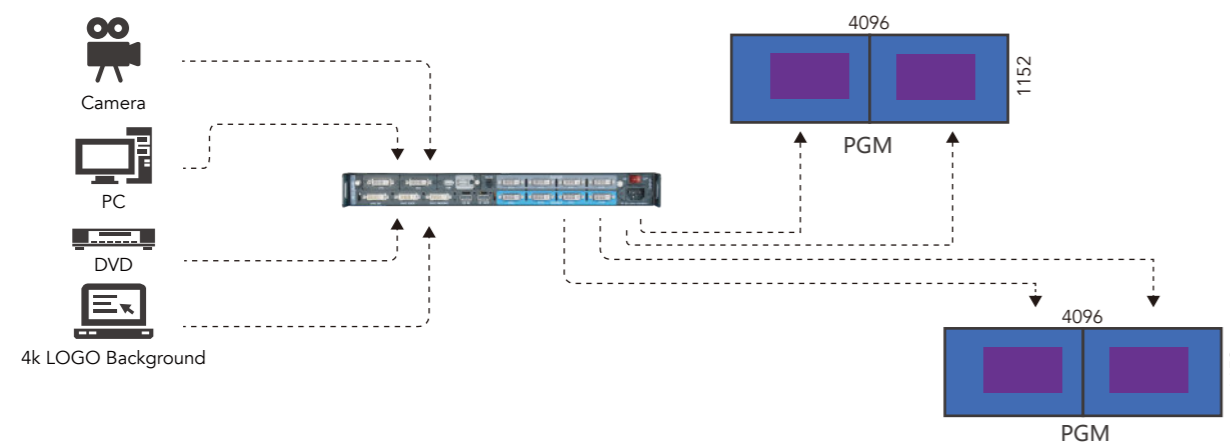

### Independent/Matrix Mode

Use X1pro e as a router with scan conversion between input and output allowing delivery of digital video to downstream devices.

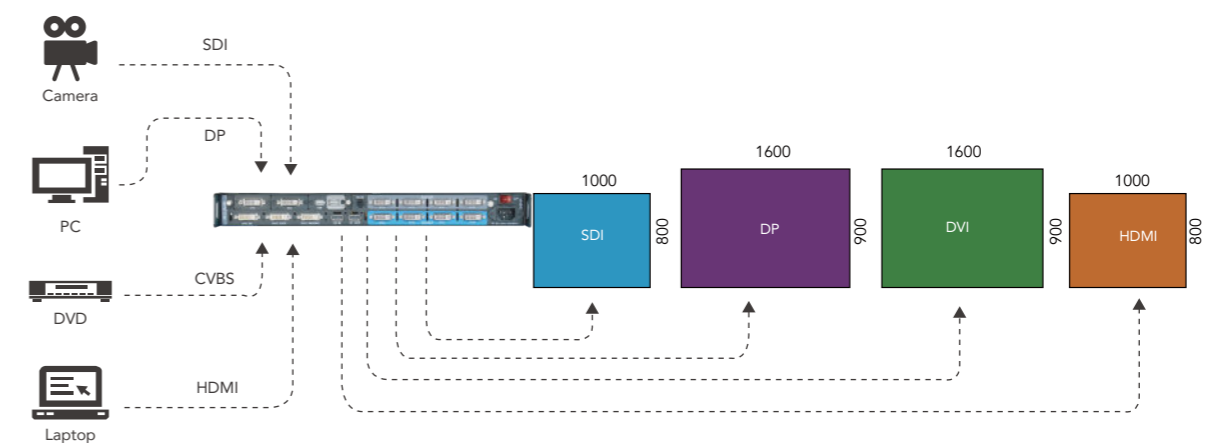

### STREAMING

- CAPTURE
- SWITCHER
- ENCODER
- CLOUD/DECODER
- ASK Series Collaboration solutions

### PRO AV

- D Series Digital Processors
- X Series Universal Processors
- M Series Mixing & Scaling
- FLEX Series Mixed Signal Matrix
- Q Series FLEX multi-signal matrix
- 1 Series Switcher/Scalers
- T Series Control Consoles
- Subito Series LED Control Solutions
- UMS Series Media Solutions
- RMS Series Monitoring Solutions
- MSP Series Video Tools/Extenders Signal Converters Signal Distributors
- Accessories
- Software
- Reference
- Contact

# X1Gpro



X1Gpro is a 2K-level LED screen display and control integrated processor. X1Gpro provides 1 optional input module and 1 SDI module to meet the needs of different engineering projects. In some municipal engineering fixed installation projects, X1Gpro provides a pair of audio inputs, which can realize audio and video synchronization switching display.

## Features

- Picture-in-Picture (PIP)
- Transition effects
- RGBlink instant TAKE with pre-Sync
- Audio controls
- Support for RGBlink OpenAPI
- On board test patterns
- Support for multi-device cascade
- Support for additional input options
- EDID management on board

## Seamless Switching

X1Gpro supports seamless switching between any in and any out, and supports TAKE pre-sync for delay free switching and signal confirmation before switch the input signal source.

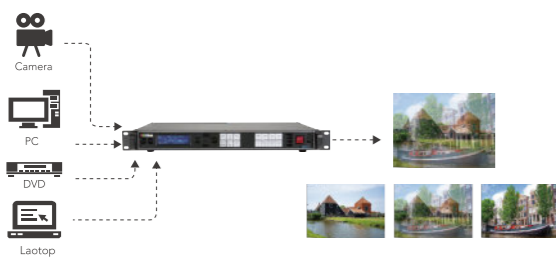

## Transition Effects

A range of transition effects are including, allowing different effects when switching between inputs signals.

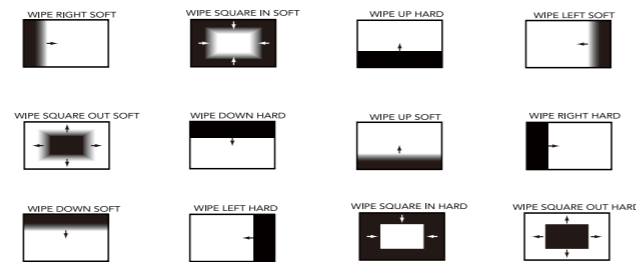

## Picture-by-Picture display

Select any input signal for use as a PIP or configure sources side-by-side as PBP (picture-by-picture) for area of interest display for specific displays. Menu functionally provides quick presets as well as refinements.

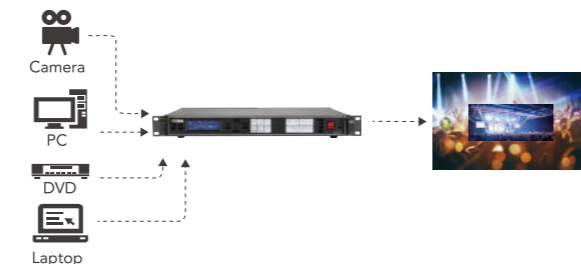

## Multi-Device Splicing

Combine multiple devices linking via HDMI to provide pixel perfect video for splicing multiple displays.

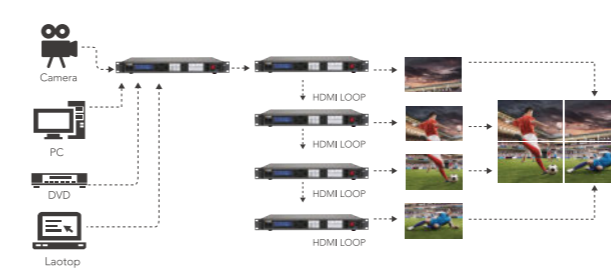

## Audio Integrated

X1Gpro supports both embedded and insert audio with both external output and embedded transmission. The RCA audio output is ideal for de-embedded audio to be connected to dedicated audio systems, while the embedded audio is ideal for transmission of audio together with video to remote LED displays that contain speakers such as in digital signage applications. Integrated audio capabilities on X1Gpro adds to the processors capabilities as a complete solution.



## Input modular option

In addition to the standard input interface, you can also choose any one input, including SDI, HDMI, HDMI IN/LOOP, USB, HDBaseT, DVI (compatible with CVBS, VGA, YPbPr).

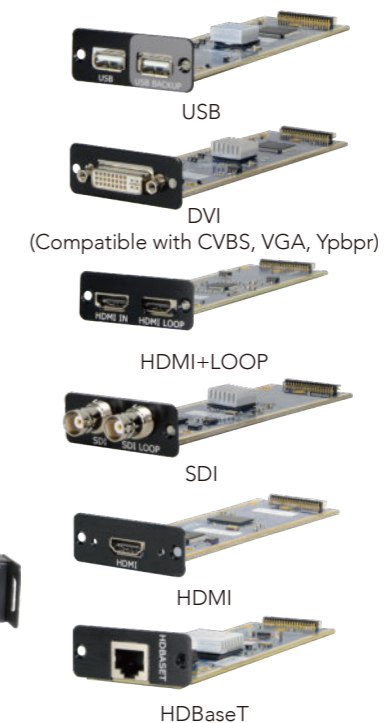

## STREAMING

- CAPTURE
- SWITCHER
- ENCODER
- CLOUD/DECODER
- ASK Series Collaboration solutions

## PRO AV

- D Series Digital Processors
- X Series Universal Processors
- M Series Mixing & Scaling
- FLEX Series Mixed Signal Matrix
- Q Series FLEX multi-signal matrix

## 1 Series Switcher/Scalers

- T Series Control Consoles
- Subito Series LED Control Solutions

## UMS Series Media Solutions

## RMS Series Monitoring Solutions

## MSP Series Video Tools/Extenders Signal Convertors Signal Distributors

- Accessories
- Software
- Reference
- Contact



# T Series Control Consoles

# T1



## Connect & Control

Connect T Series console to compatible RGBlink processors via a Cat6e cable. Click search and connect, to immediately them be able to configure and control the connected processor.

## External Display

Connect an external monitor for duplication of on board controls display.

## Interactive Touch Screen

On board LCD displays are touchscreen enabled intuitive navigation and controls.

## Video Streaming

When connected to a H.264 preview streaming enabled processor, T Series consoles display video sources directly in the configuration allowing users to have a realistic representation of both presets and preview/program operations.



Take control of live events with T1, putting full power of control with the programmer and operator. T Series consoles features integrated LCD touch screen displays front and centre, allowing full view of configuration of connected processors. With large dynamically illuminated keys, along with OLED electronic legends for superior visibility, T Series console provide immediate hands on controls essential for live work environments including stage, broadcast and control rooms.

T Series controllers come to live when connected to selected RGBlink advanced processors from the X Series.

Utilizing the power of the RGBlink XPOSE platform, T Series controller offers fluid and demand based video wall control from a convenient tactile interface, opening up new possibilities and enabling supplicated video presentations.

## Configure & Preset

Configure all the attributes of connected processors visually, and well as recall, program and save presets on the remote processors.

## Dedicated to Control

The live control section of the T Series consoles includes familiar T-Bar and TAKE buttons along with related output controls positioned for clear and optimal access.

## Dynamic Control Surface

T Series application keys are conveniently arranged in groups. OLED displays above each key provide a legend as to the function of the key, and may be configured or personalised with text or graphics to the users requirements.

## Convenient Control

To aid in configuration and data entry, T Series consoles include a variety of input methods which not only include the touch screen, but also a dedicated numeric pad and three-axis joystick precision joystick.



## STREAMING

- CAPTURE
- SWITCHER
- ENCODER
- CLOUD/DECODER
- ASK Series Collaboration solutions

## PRO AV

- D Series Digital Processors
- X Series Universal Processors
- M Series Mixing & Scaling
- FLEX Series Mixed Signal Matrix
- Q Series FLEX multi-signal matrix
- 1 Series Switcher/Scalers

## T Series Control Consoles

- Subito Series LED Control Solutions
- UMS Series Media Solutions
- RMS Series Monitoring Solutions
- MSP Series Video Tools/Extenders Signal Convertors Signal Distributors

- Accessories
- Software
- Reference
- Contact

# Tgo

## Video Control at your Fingertips

Portable and lightweight, Tgo goes wherever control is needed. The compact format contains not just a 8 inch touch screen display, but also the power of XPOSE® controls. Connect remote preview enabled processors directly to one of the gigabit LAN ports to not only switch between presets but also preview source video directly on Tgo. Enhance video control operations by adding an extended monitor and peripherals including keyboard and mouse to create the ultimate video control station.

### Features

- Standalone XPOSE powered video control
- 8inch touch screen
- Preview source video and presets
- Customisable touch keys
- Multiple direct Gigabit ethernet connections
- USB3.0 support for external peripherals
- HDMI port for monitor



### Designed for You

Tgo is equally at home for events and installation applications with options for not only desktop use, but also wall mounting and rack mounting

### Preset Control

Recall presets from connected processors, previewing directly on the Tgo display before switching to output. Multi-mode support is available for processors configured with differing operations. Select presets from across multiple banks on the selected processor.

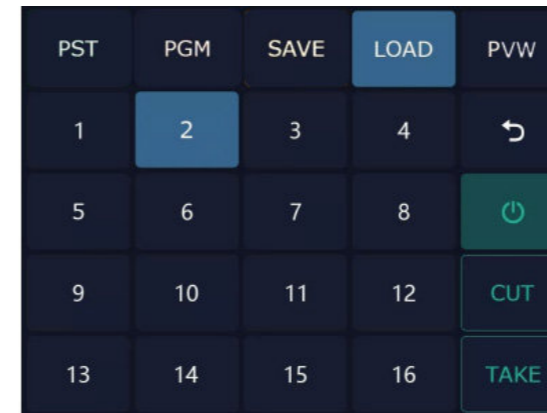

### Custom Layouts

Customise buttons with icons and/or text, tailoring Tgo to specific applications or events.

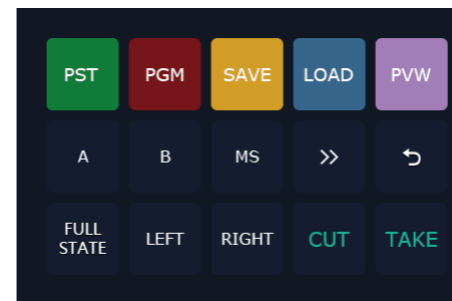

### Extend

Asd USB keyboard and mouse for more control and connect an HDMI to take full control of configuration and control possibilities on demand.



### Multi-View

Display video sources in configurable multi-views.



### Live Presets

View presets with live video previews on the Tgo display when connected to enabled processors.

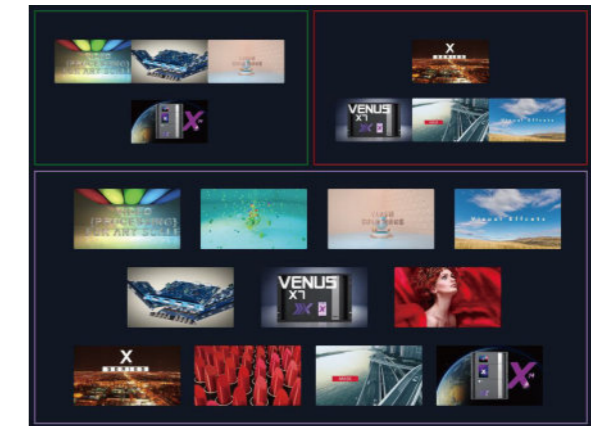

### Centralised Control

Control complete systems of not just multiple displays, but also multiple devices from across the X universal processor and FLEX/FLEXpro range.

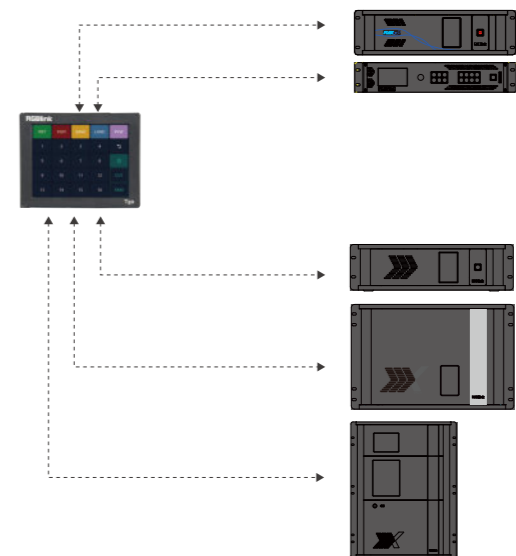

### STREAMING

- CAPTURE
- SWITCHER
- ENCODER
- CLOUD/DECODER
- ASK Series Collaboration solutions

### PRO AV

- D Series Digital Processors
- X Series Universal Processors

- M Series Mixing & Scaling

- FLEX Series Mixed Signal Matrix

- Q Series FLEX multi-signal matrix

- 1 Series Switcher/Scalers

- T Series Control Consoles

- Subito Series LED Control Solutions

- UMS Series Media Solutions

- RMS Series Monitoring Solutions

- MSP Series Video Tools/Extenders Signal Convertors Signal Distributors

- Accessories

- Software

- Reference

- Contact



**Subito Series**  
LED Control Solutions



## The Future of LED Control Today

LED control evolved for modern displays and applications, the Subito™ system developed by RGBlink brings together familiar yet streamlined configuration functionality tightly integrated with video control providing key entry points opening up whole new possibilities and increasing efficiency while offering exceptional performance.

### Feature

- Fully integrated to processing solutions with no gap or encode-decode loop
- Configure and control all display attributes from a single point and application
- Full 2K support per Subito TX Quatro output module
- Enables compact and dense installation saving space and increasing efficiency
- Takes advantage of native processor capabilities for redundancy and backup without duplication
- Integrate seamlessly via RGBlink OpenAPI
- Optimize operations and performance with the Subito Inside certified LED panels

### Integrate Seamlessly

Use RGBlink XPOSE and OpenAPI to control video processing and LED display control via a single end-point including status reporting and monitoring.

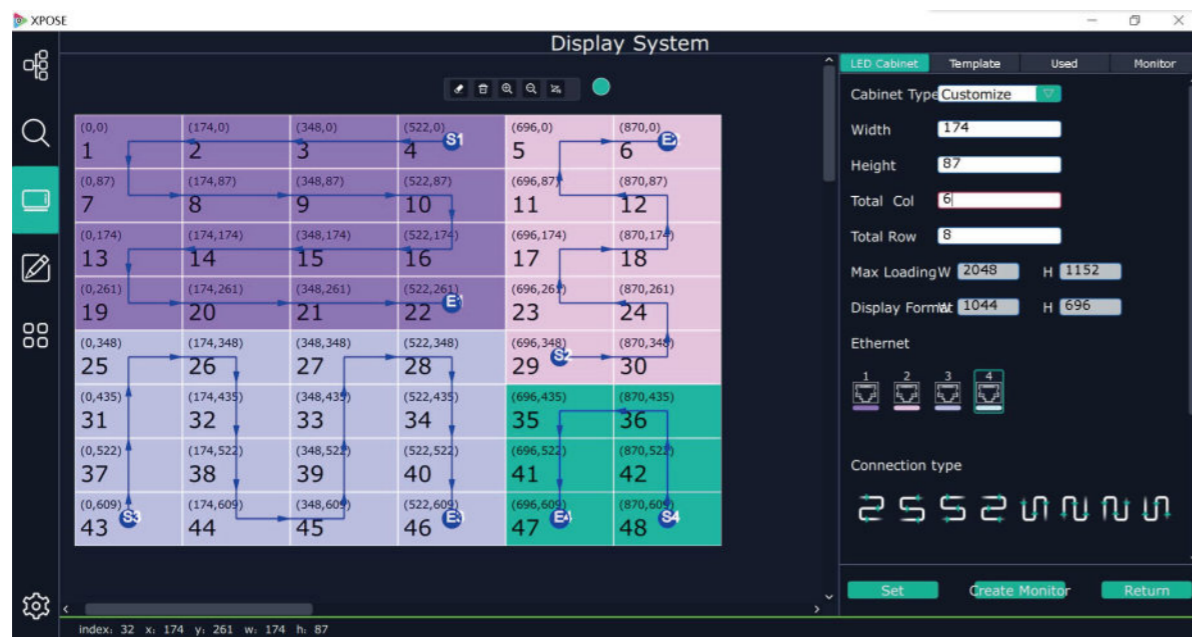

### Library Profiles for LED Panels

All certified Subito panels are registered in a downloadable library, simply detect or select panels from the list directly within XPOSE. Profiles are optimized for by the LED panel manufacturers for quality and performance.

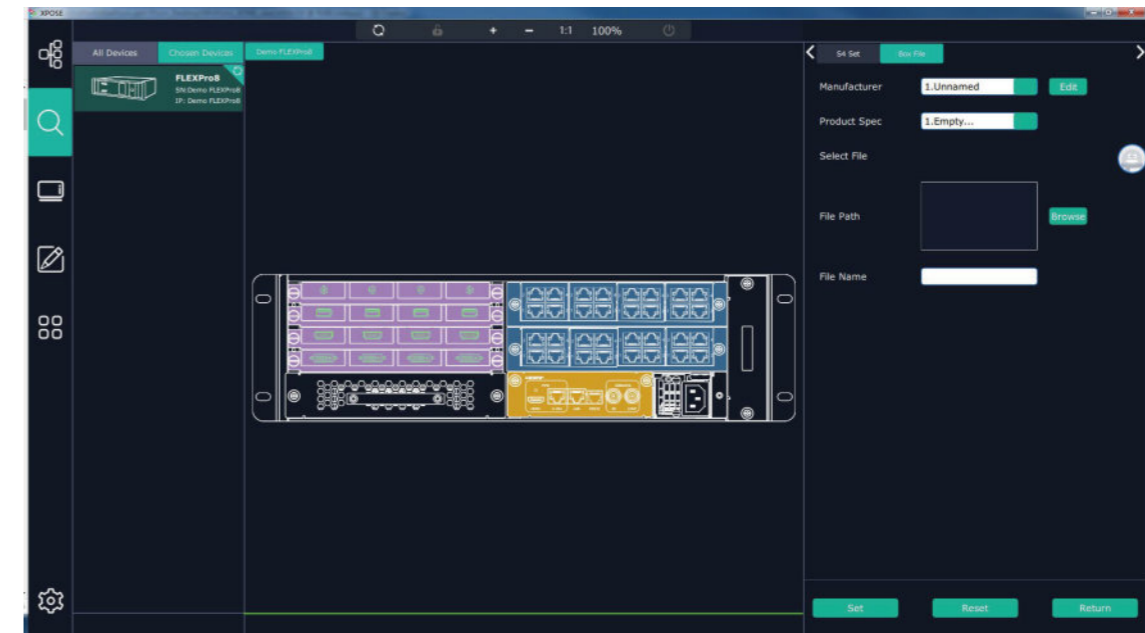

### Generate Complete Display Solutions

For rental or multisite roll outs, build a library of LED display assemblies that can be recalled and transported easily.

### Configure Freedom & Dynamically

Go beyond conventional pixel resolutions with multi Quatro TX modules for large or multiple display areas.

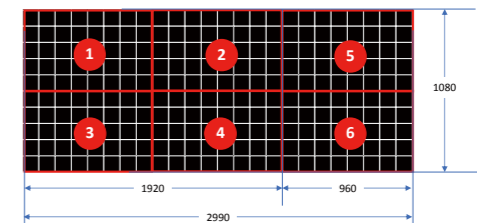
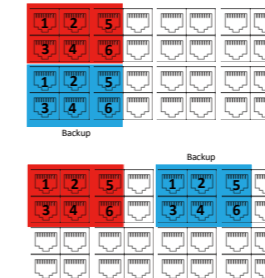

### Backup & Loop

Configure backups on any port or slot without the need for additional processing or rack space.

### Monitoring and Detect

In configuration see the status of each panel including ID, port, status and resolution. Detect errors and performance of LED panels directly from within XPOSE

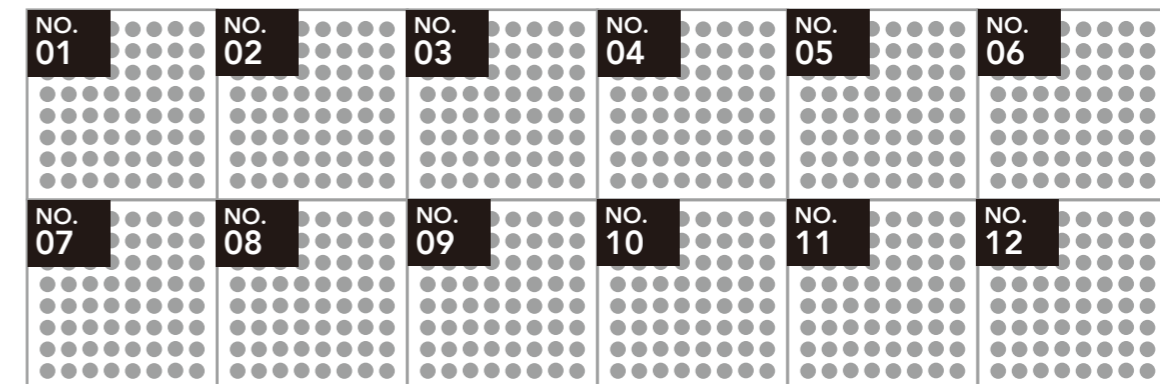

### STREAMING

- CAPTURE
- SWITCHER
- ENCODER
- CLOUD/DECODER

### PRO AV

- D Series Digital Processors
- X Series Universal Processors
- M Series Mixing & Scaling

### FLEX Series Mixed Signal Matrix

### Q Series FLEX multi-signal matrix

### 1 Series Switcher/Scalers

### T Series Control Consoles

### Subito Series LED Control Solutions

### UMS Series Media Solutions

### RMS Series Monitoring Solutions

### MSP Series Video Tools/Extenders Signal Converters Signal Distributors

### Accessories

### Software

### Reference

### Contact



### Solutions for Integration & Events

Take advantage of native no-gap Subito modules in a growing range of integrated video and display solutions.

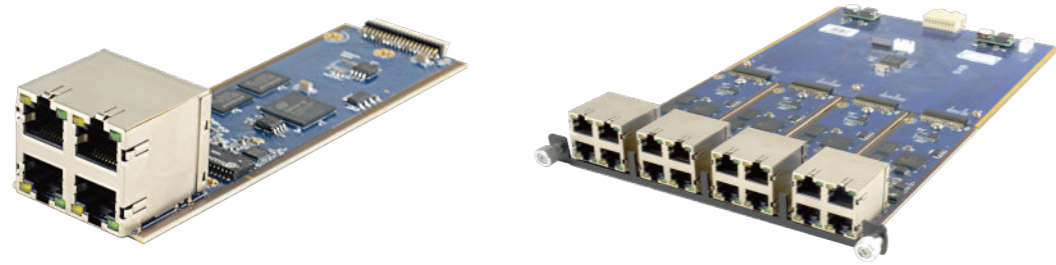

#### FLEX pro8

The premier solution for larger scale applications requiring up to 18 mega pixels. Fit up to 8 SubtoTX Quatro output modules with support for up to 32 video layers.



#### GX4

Ideal for single display applications that require ease of use and local tactile operation via the front panel. Connect displays up to 2.6 million pixels.



#### S4

For conversion of existing systems or standard alone LED display systems, Connect to displays up to 2.6 million pixels.

### Solutions for Manufacturers

Take advantage of Subito technologies with Subito RX Receiver Cards in a range of standard formats and configurations to suit panels of all formats.

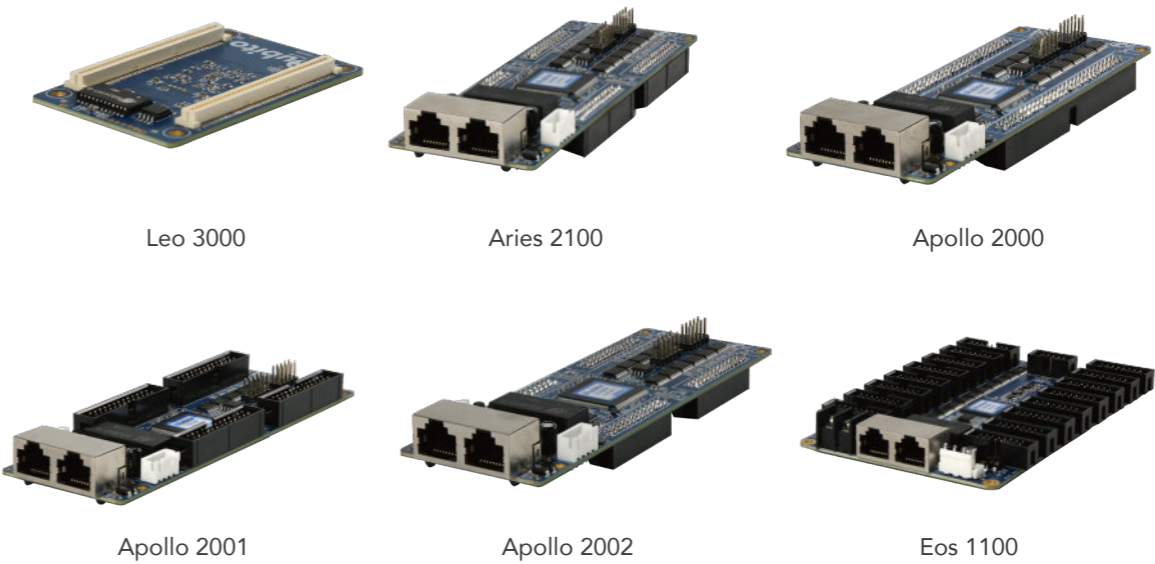

### Deliver Solutions

Subito manufacture partners are able to provide XPOSE with their own profiles defaulted as standard, a solution that allows personalization without the overhead of maintaining OEM software.

### Get Certified

The Subito partner program provides a profile build tools, and all certified Subito fitted panels are listed in a common profile library – customers can always access the manufacturer certified profile when using panels in displays.



\* Subito RX Receiver technologies available from select certified manufacturers and OEMs

### STREAMING

- CAPTURE
- SWITCHER
- ENCODER
- CLOUD/DECODER
- ASK Series Collaboration solutions

### PRO AV

- D Series Digital Processors
- X Series Universal Processors
- M Series Mixing & Scaling
- FLEX Series Mixed Signal Matrix
- Q Series FLEX multi-signal matrix
- 1 Series Switcher/Scalers
- T Series Control Consoles

### Subito Series LED Control Solutions

- UMS Series Media Solutions
- RMS Series Monitoring Solutions
- MSP Series Video Tools/Extenders Signal Convertors Signal Distributors

- Accessories
- Software
- Reference
- Contact

# GX4pro



## No-gap scaling, processing and control

GX4pro is a video processor which supports DVI output resolution at 2048x1152@60 and offers multiple test pattern output resolution options. Beside standard with a 1 HDMI (with loop), 1 CVBS, 1 VGA, 1 DVI and 1 pair of Audio analog connectors, it also comes with 1 empty module slots for any single input modules selecting from HDMI, DP, DVI, SDI, VGA, CVBS and USB modules. Capability of support any input makes GX4pro have features of PIP (dual pictures), synchronized video with audio control and seamless switching between different inputs. Moreover Extended Display Identification Data (EDID management) make sure display perfectly spot to spot. GX4pro can work as LED display controller when universal sender cards is installed. There are 2 empty slots fitting for one 2.6mega pixels sender card or two 1.3mega pixels sender cards. RGBlink dedicated sender card module SubitoNX™ Quatro is an also an option to control LED display. It provides 2.3 mega pixels display up to horizontal 3840 pixels or vertical 1920 pixels, through 4 RJ45 ports.

### Features

- Five standard inputs including SDI
- Seamless switching between any input
- RGBlink instant TAKE with pre-Sync
- Transition effects
- Picture-in-Picture (PIP)
- Audio controls
- Optional RGBlink Subito NX™ Quatro Sender
- Support for up to 2.6 mega pixels
- Support for user-fit input option
- EDID management on board
- On board test patterns
- Support for multi-device cascade
- Compact 1U footprint

### Seamless Switching

GX4pro supports seamless switching between any in and any out, and supports TAKE pre-sync for delay free switching and signal confirmation before switch the input signal source.

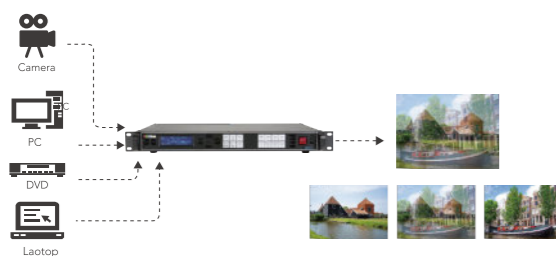

### Transition Effects

A range of transition effects are including, allowing different effects when switching between inputs signals.

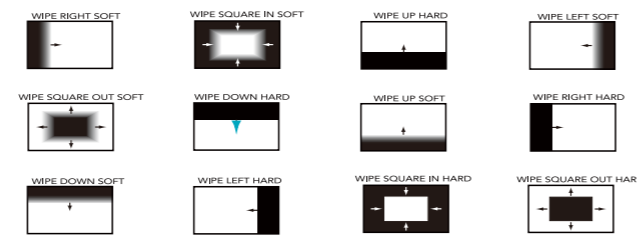

### Picture-by-Picture display

Select any input signal for use as a PIP our configure sources side-by-side as PBP (picture-by-picture) for area of interest display for specific displays. Menu functionally provides quick presets as well as refinements.

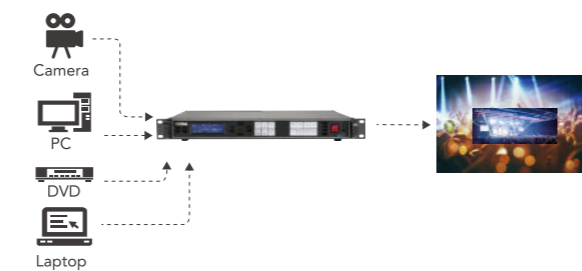

### SDI as Standard and More

GX4pro features five input signals including much in demand 3G-SDI and HDMI. In addition a slot is provided for a user fit input signal of choice. Choose from a wide range of popular signals including SDI, HDMI, HDBaseT, USB Media and more to configure GX4 to a particular application environment.

### Audio Integrated

GX4pro supports both embedded and insert audio with both external output and embedded transmission. The RCA audio output is ideal for de-embedded audio to be connected to dedicated audio systems, while the embedded audio is idea for transmission of audio together with video to remote LED displays that contain speakers such as in digital signage applications. Integrated audio capabilities on GX4pro adds to the processors capabilities as a complete solution.



### Multi-Device Splicing

Combine multiple devices linking via HDMI to provide pixel perfect video for splicing multiple displays.

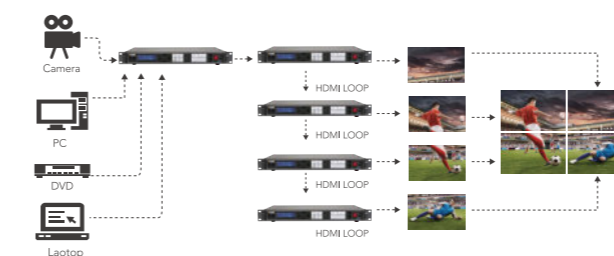

### LED Display Configuration

Set up and dynamically configure connected LED displays directly from within the GX4pro menu, providing a complete display management solution\*.

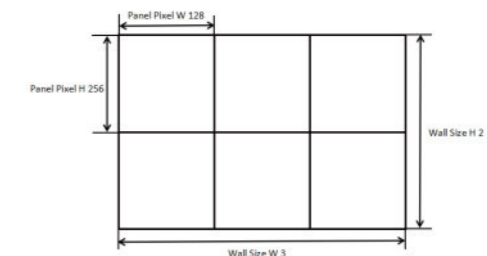

### Support Multi-Format Cabinets

Configure LED panels or cabinets of multiple pixel sizes in one connection to support creative and integration applications\*.

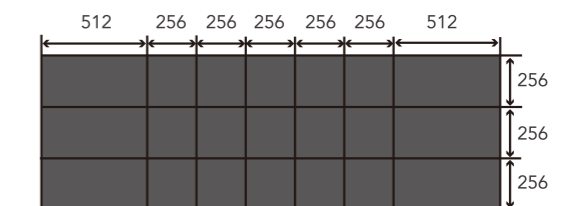

### LED Panel Profiles

With an optional Subito Quatro Sender installed, take advantage of library profiles for import and quick configurations.

\*Features vary by (optional) LED Control System fitted.

## STREAMING

- CAPTURE
- SWITCHER
- ENCODER
- CLOUD/DECODER
- ASK Series Collaboration solutions

## PRO AV

- D Series Digital Processors
- X Series Universal Processors
- M Series Mixing & Scaling
- FLEX Series Mixed Signal Matrix
- Q Series FLEX multi-signal matrix

- 1 Series Switcher/Scalers

- T Series Control Consoles

- Subito Series LED Control Solutions

- UMS Series Media Solutions

- RMS Series Monitoring Solutions

- MSP Series Video Tools/Extenders Signal Convertors Signal Distributors

- Accessories

- Software

- Reference

- Contact



**UMS Series**  
Media Solutions

# UMS4

## The Platform for Performance Media Software

Digital media delivery, whether player, server or capture applications are demanding in the extreme, requiring the best in high performance hardware. The RGBlink UMS Series of computer hardware delivers just that, with latest generation Intel i7 processors and a choice of professional Nvidia and AMD Radeon GPUs.

Reliability is essential too, with UMS media servers including features such as hot-swappable redundant power supply options, front panel SSD slots, dual port networking along with front panel monitoring from the integral touch screen display.

Connectivity is king with up to 12K of configurable output via the RGBlink isolated DisplayPort connector panel, protecting the GPU card from connector turn degradation. Two slots are provided for installation of a select platform approved capture cards including 12G-SDI and HDMI 2.0.

Robustness and reliability of the UMS platform is further enhanced with a rugged rack mount housing and internal dampening.

UMS solutions are ideal companions for video wall processors and similar devices, and perfect for integration, digital signage and events applications.

- Installation friendly high performance media graphics platform
- Choice of three models
- Workstation CPUs & GPUs  
Windows 10 pre-installed
- RGBlink MPS media processing system
- Support for BYO media server software & apps



4 SSD Slots



Optional Redundant PSU



On board touch screen control & monitoring



Dual LAN Ports



## Control Remotely

RGBlink Advanced Media Processing System (MPS) software access licenses are provided, enabling remote connection a control of media on a UMS4.



Control multiple MPS instances remotely, providing opportunities to deliver media at almost any scale

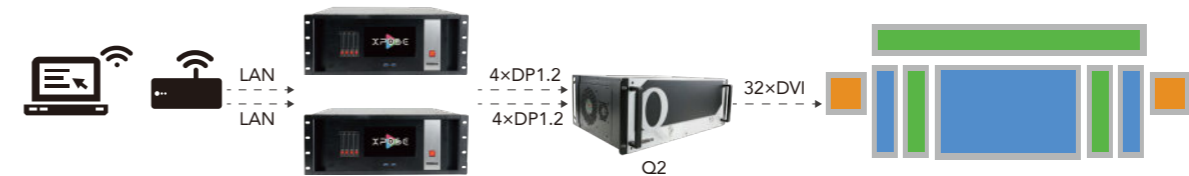

## Multi-Source Layering

Use RGBlink MPS to configure and output multiple video sources as layers, windows or PIPs, allowing outputted media to be tailored the needs of downstream processors and displays directly from the source.



## Multi-4K Video Media Platform

True multi-signal 4K and 8K video delivery platform, the UMS4 Series media provides the raw power demanded for modern hi-density and largescale media display applications with ease.



\* UMS4 max shown as example configuration. Refer to Specifications and Guides

## STREAMING

- CAPTURE
- SWITCHER
- ENCODER
- CLOUD/DECODER
- ASK Series Collaboration solutions

## PRO AV

- D Series Digital Processors
- X Series Universal Processors
- M Series Mixing & Scaling
- FLEX Series Mixed Signal Matrix
- Q Series FLEX multi-signal matrix

- 1 Series Switcher/Scalers

- T Series Control Consoles

- Subito Series LED Control Solutions

- UMS Series Media Solutions

- RMS Series Monitoring Solutions

- MSP Series Video Tools/Extenders Signal Convertors Signal Distributors

- Accessories

- Software

- Reference

- Contact

### Choice of Three Models

UMS4 is available in a range of models, scaling to the most demanding workloads. Select from pro, plus and max .

The max model features a 14 core Intel i9 processor coupled two Nvidia Quadro P5000 GPUs.

Each UMS4 model is optimized with pro workstation components for overall video performance

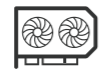
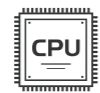

UMS4 pro	UMS4 plus	UMS4 max
Intel i7 10 <sup>th</sup> Gen Comet lake 8core/16Thread	Intel i9 10 <sup>th</sup> Gen Comet lake 10core/20Thread	Intel i9 10 <sup>th</sup> Gen Comet lake 14core/28Thread
Nvidia Quadro 1 x P4000 8GB GDDR5	AMD Radeon Pro 1 x WX9100 16GB GDDR5	Nvidia Quadro 2 x P5000 16GB GDDR5X
Kingston HyperX Fury 32GB DDR4 3200	Kingston HyperX Fury 32GB DDR4 3200	Kingston HyperX Fury 64GB DDR4 3200
Samsung M.2 1 x 1TB Internal SSD	Samsung M.2 2 x 1TB Internal SSD	Samsung M.2 1 x 2TB Internal SSD

### Video Capture Connectivity

Dual slots are provided for the installation of capture cards. Choose from 2K & 4K selected RGBlink certified Magewell HDMI and SDI options that are independently mounted from the back panel via an RGBlink connector panel to improve reliability and service lift.



### RGBlink MPS

Advanced Media Processing System software takes full advantage of the available GPU to deliver enhanced video output from on-disk pre-recorded or capture sources free of jitter and motion-blur .

MPS supports full bandwidth uncompressed video with full fidelity, whether delivering to one output or four, splitting and stitching across outputs to requirement at full frame rate.

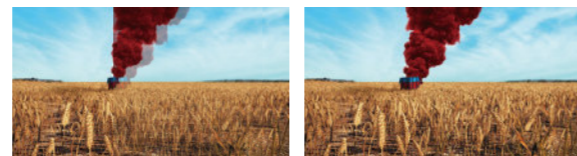

### Touch Screen Display & App Launcher

Onboard the UMS4i is a 7in touch screen, making the pc platform fully self contained and ideal for rack mounted installations whether across rental or fixed installation.

The UMS app launcher boots to the front panel display allowing quick and easy way of launching software as well as a range of diagnostics.



## UMS4 max

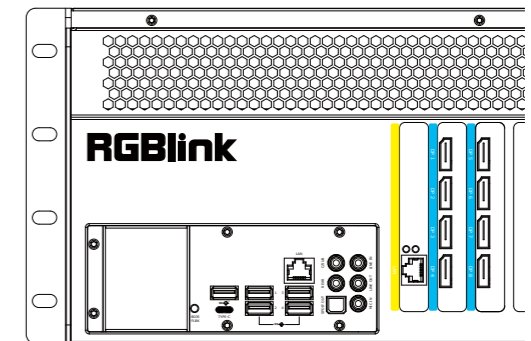

Standard with eight DisplayPort 1.4 outputs, UMS4 max supports resolutions up to 7680x4320@30 or 7680x2160@60 on single cable or up to eight 4K displays

## UMS4 plus

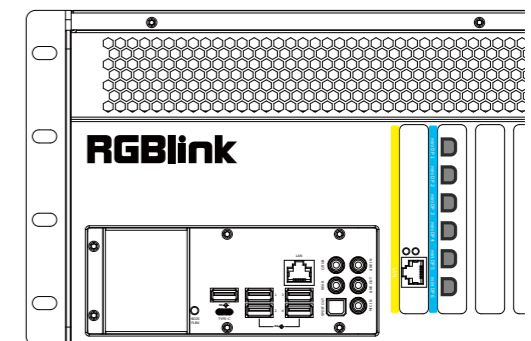

Featuring mDP (mini DisplayPort) outputs with DP1.4, UMS4 plus powers up to six 4K displays

## UMS4 pro

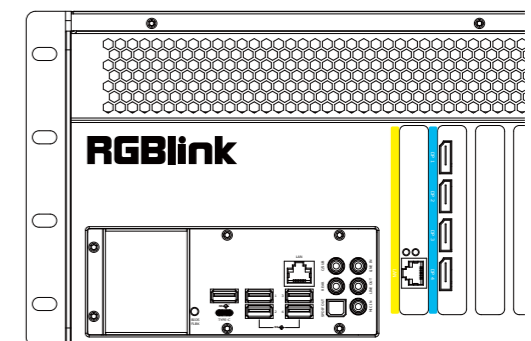
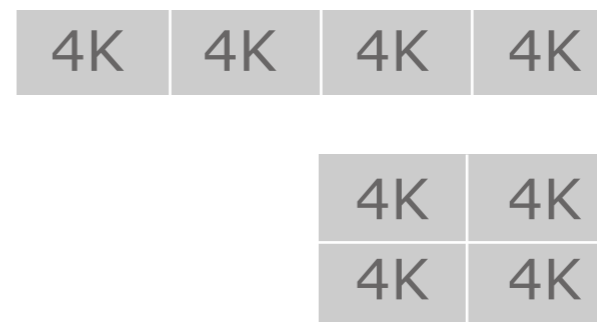

Four 4K DisplayPort 1.4 outputs

### STREAMING

- CAPTURE
- SWITCHER
- ENCODER
- CLOUD/DECODER
- ASK Series Collaboration solutions

### PRO AV

- D Series Digital Processors
- X Series Universal Processors
- M Series Mixing & Scaling
- FLEX Series Mixed Signal Matrix
- Q Series FLEX multi-signal matrix
- 1 Series Switcher/Scalers
- T Series Control Consoles

### Subito Series LED Control Solutions

### UMS Series Media Solutions

### RMS Series Monitoring Solutions

### MSP Series Video Tools/Extenders Signal Convertors Signal Distributors

### Accessories

### Software

### Reference

### Contact



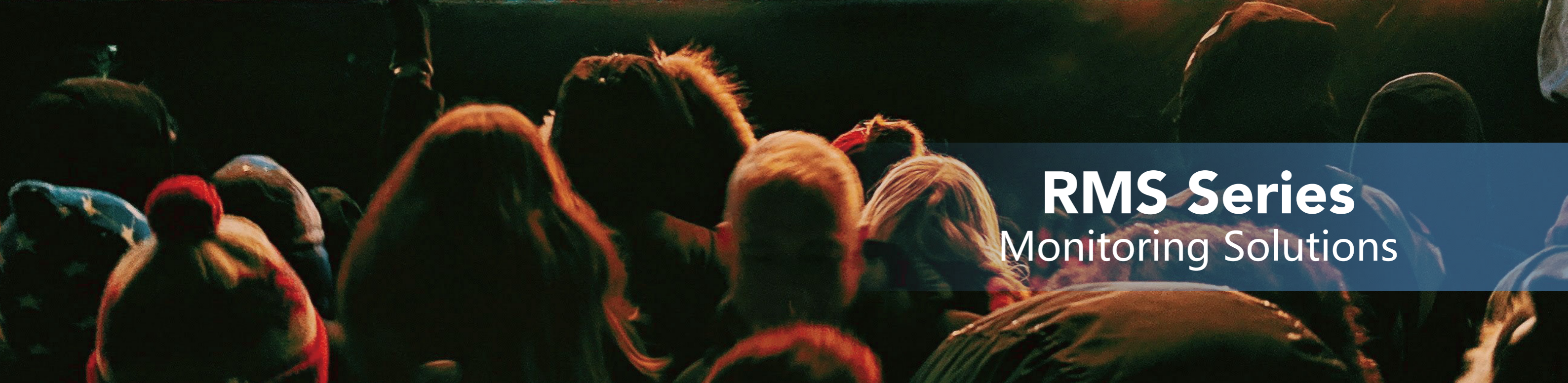

**RMS Series**  
Monitoring Solutions

# RMS 8424S



## Displays to Impress

RMS 1A and RMS 8424S both feature 8in LCD displays in a 16:9 aspect and native resolution of 1024x600 pixels.

Each of three 5in displays in an RMS 5353 also have a 16:9 aspect ratio, while native resolution is 800x480 pixels.

## Preview USB

All models include a USB-A input so USB media may be shown on the display, ideal for previewing digital media before use in a media device.

## Monitor Audio

RMS 8424S has built in speakers complimenting each display, along with mini Jack sockets

## Tally Support

The larger models support Tally signals and include signal lights above each LCD display.

## Preview Multiple Signal Types

Across the range, all models have support for DVI, HDMI and VGA. The larger RMS 8424S also having dedicated Composite in/loop connectors, and optionally 3G-SDI in/loop.

RGBlink preview monitors are the essential accessory whether rack mounted with equipment or used stand-alone. All models offer a wide range of input resolution support up to 4K despite their compact size. Use RMS monitors connected directly supported to video output, or use inline, and loop through the video source.



## RMS 1516

Desktop or rack mounting 4K display, the RMS-1516 15.6in LCD monitor accepts HDMI, VGA, DVI, SDI signal inputs, each with loop. Video with HDR encoding is supported and the monitor is HDCP 1.4 compliant. In addition to full screen preview of a selected signal, RMS1516 also includes a Multiview and has on board picture adjustments including color temperature and flip/mirror.

# RMS 1A

## Compact & Convenient

RMS 1A is the ultimate compact monitor, and ready to work as a monitor block to build for different application.



## Desktop Monitor

Complete with desk stand, RMS 1A can be positioned almost anywhere, and with view angel adjustable.

## Rack Solution

Add a rack mount accessory to the RMS 1A to conveniently rack mount, in a similar way to the larger models, allowing these monitors to be positioned together with related equipment.



## Creative Solution

Monitoring to the wall in different degree and surface, RMS 1A helps to make the creative idea comes true with light demo installation.

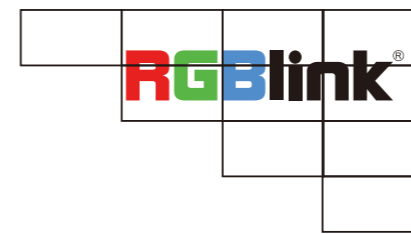

## STREAMING

- CAPTURE
- SWITCHER
- ENCODER
- CLOUD/DECODER
- ASK Series Collaboration solutions

## PRO AV

- D Series Digital Processors
- X Series Universal Processors
- M Series Mixing & Scaling
- FLEX Series Mixed Signal Matrix
- Q Series FLEX multi-signal matrix

## 1 Series

## Switchers/Scalers

## T Series

## Control Consoles

## Subito Series

## LED Control Solutions

## UMS Series

## Media Solutions

## RMS Series

## Monitoring Solutions

## MSP Series

## Video Tools/Extenders

## Signal Convertors

## Signal Distributors

## Accessories

## Software

## Reference

## Contact



# MSP Series

Video Tools/Extenders  
Signal Convertors Signal/Distributors

# MSP 200PRO

## Signal Monitor & Generator



Format and Test Pattern Generation are just two of the many features of MSP200pro.

Built in are standard video outputs for 3G-SDI, DVI/HDMI and CVBS. Set the output format from the built-in touch screen display by selecting from a wide range of common formats.

Popular test patterns can be easily selected with motion or without, and time code can be generated and displayed allowing inspection frame delay.

MSP200pro also includes a USB media input port as standard – use a MPEG4 or image as a test signal source, opening up many possibilities for producing bespoke testing configurations.

Optional install an SDI or HDMI input module to make use of other external video sources. And EDID management is built right in too.

### Preview

Use MSP200pro as a remote preview monitor. Insert USB media for on screen display, and use that media (video or images) for output. Add the optional HDMI or SDI interface and both preview and pass through that external source too.

### Genlock

Genlock Y is supported and looped through. If this not used, then MSP200pro can generate Genlock Y or HS/VS.

### Wave Form Inspection

Several wave form inspection graphs are available on screen, and in addition graphing of the audio signal can be displayed.

### Test Patterns

A range of common test patterns are built in and selectable via the touch screen interface. Motion of a pattern can be turned on/off.

Additional test patterns of test images can be used by setting the input source to the standard USB input, and selecting custom files from USB.

### Format Generator

A huge range of industry standard formats for both resolution and refresh are available for selection on board MSP200pro. These set the format for the standard SDI, CVBS and DVI output interfaces. The DVI port supports HDMI (10bit) as well as VGA, using adapters.

### Audio

On board audio is available and output on both the audio jack and to signals that support embedded audio. When using external media (USB or the optional SDI/HDMI), embedded audio is passed through.

### Portable

MSP200pro supports battery operation - simply fit standard Li-on batteries to the internal compartment.

### Rugged

MSP200pro is designed for the mobile professional. The extended housing helps protect connectors and there is strong glass cover for the touch display. MSP200pro comes complete with case for the ultimate in protection between locations.



# MSP 331

## HDMI to USB-C Capture

The MSP 311 HDMI 2.0 Audio Extractor with HDCP 2.2 could extract audio signals from any HDMI compliant source to digital optical or analog stereo L/R audio outputs. Further, both input and output HDMI support video resolution up to 4K 2K@50/60Hz (YUV4:4:4). It supports 10bits HDR(High Dynamic Range) pass through and HDMI high resolution digital audio formats bypass, LPCM 2CH, Dolby True HD, Dolby Digital Plus, Dolby Atmos and DTS-HD Master Audio, audio sampling rate up 192kHz.HDCP 2.2 and CEC bypass are supported.



# IC2

## Distributed Integration Manager

Meeting the growing requirements for distributed management, control and display of compute and other video systems, IC2 is so much more than KVM.IC2 provides secure IP based and advanced RGLink video technologies for demanding environments where high performance and quality are essential. Designed for multi-point applications, RGLink IC2 are universal transmitter receivers that can be employed in a wide range of combinations in support of a diverse and dynamic range of applications.Each device as receiver/RX can support display of multiple video sources in flexible layouts with features including zoom and overlay. Videos sources up to 1080p60 are delivered with low latency and high quality. Switching between sources is seamless and glitch free. USB mouse, keyboards and serial control devices may be used allowing remote control of connected computers from any designated point of control.

### STREAMING

- CAPTURE
- SWITCHER
- ENCODER
- CLOUD/DECODER
- ASK Series Collaboration solutions

### PRO AV

- D Series Digital Processors
- X Series Universal Processors
- M Series Mixing & Scaling
- FLEX Series Mixed Signal Matrix
- Q Series FLEX multi-signal matrix

- 1 Series Switcher/Scalers

- T Series Control Consoles

- Subito Series LED Control Solutions

- UMS Series Media Solutions

- RMS Series Monitoring Solutions

- MSP Series Video Tools/Extenders Signal Convertors Signal Distributors

- Accessories

- Software

- Reference

- Contact

## Extenders – cat5/6

### MSP 329 – HDMI | H.264 Extender



Extend HDMI signals along with keyboard and mouse (KVM) support to remote displays with the MSP329 Set. HDMI 1.4 signals up to 4K@30 or 4K@60 YUV 4:2:0 may be transmitted via Ethernet. In addition to USB connections, IR support is provided too via mini Jack connections.



### MSP 325N – HDMI 2.0 Encoder

Extend HDMI signals along with keyboard and mouse (KVM) support to remote displays with the MSP329 Set. HDMI 1.4 signals up to 4K@30 or 4K@60 YUV 4:2:0 may be transmitted via Ethernet. In addition to USB connections, IR support is provided too via mini Jack connections.



4K | HDR

### MSP 330 – 10G SDVoE Fiber Extender

Encode and transmit HDMI over IP with support for HDMI 2.0b, HDCP, HDR and more

Inputs:

- 1x Optical Fiber In (LC female)
- 1x IR In (3.5mm Stereo Mini-jack)

Outputs:

- 1x HDMI Type A (19-pin female, HDMI 2.0)
- 1x IR Out (3.5mm Stereo Mini-jack)
- 1x RS-232 (3.81mm Phoenix connector)



4K | HDR



### MSP 325H – HDMI Encoder

Encode HDMI signals for H.265 or H.264 IP streaming transmission with the MSP325H. Resolutions up to 1080p are supported with facility for audio insert via the mini Jack port. On board features include OSD and LOGO which can be set via LAN connection along with other settings to configure resolution and bit rate.

### MSP 315-4 – HDMI 1.4 to HDBaseT Extender Set

The MSP 315 HDMI extender adopts a single CAT5/CAT6 cable, including the Transmit terminal (TX) and Receiving Terminal (RX). A single CAT 5 and CAT6 cable extends the 1080P full HD HDMI signal distance to 100m. The MSP 315 supports lossless audio formats such as 4K\*2K (3840\*2160@30hz), 1080p full HD resolution, HDCP transmission protocols, high bit rate (HBR) Dolby TrueHD and dts-hd Master.



MG



### MSP 326L – H.265 Decoder And Transcoder

MSP 326L supports stream decoding of mainstream standards such as H.265 and H.264; supports standard Audio and video stream decoding in quasi-TS stream format; HDM output resolution can support 4K@60Hz (3840\*2160@60HZ) Support HLS, RTMP, RTSP, UDP/MULTICAST, Onvif and other mainstream the network protocol; 1 channel two-channel audio output, supports decoding of AAC-LC, G.711 audio formats; Built-in webserver for management and configuration via browser

### MSP415 – HDMI | HDBaseT Set

Extend HDMI signals over Cat5/6 cables with the MSP415 HDBaseT Extenders. Delivered as a Transmitter and Receiver pair, MSP415 supports signals up to 4K DCI (4096x2160@60Hz) with 8bit YUV 4:4:4 color space and support for HDCP 2.x and HDR technologies.



\* MG product may be fitted into MSP Garage

## STREAMING

CAPTURE

SWITCHER

ENCODER

CLOUD/DECODER

ASK Series  
Collaboration solutions

## PRO AV

D Series  
Digital Processors

X Series  
Universal Processors

M Series  
Mixing & Scaling

FLEX Series  
Mixed Signal Matrix

Q Series  
FLEX multi-signal matrix

1 Series  
Switcher/Scalers

T Series  
Control Consoles

Subito Series  
LED Control Solutions

UMS Series  
Media Solutions

RMS Series  
Monitoring Solutions

MSP Series  
Video Tools/Extenders  
Signal Converters  
Signal Distributors

Accessories

Software

Reference

Contact

# MSP

## Extenders – Fiber



MG

### MSP 209M – Ethernet | Multi Mode Fiber

For Ethernet connections up to 1km, MSP209M is a IEEE802.3ab 1000Base-T and IEEE802.3z 1000Base-LX compliant device set, supporting up to Gigabit Ethernet. MSP 209S is supplied “ready to use”.



MG

### MSP 209S – Ethernet | Single Mode Fiber

For Ethernet connections up to 10km, MSP209S is a IEEE802.3ab 1000Base-T and IEEE802.3z 1000Base-LX compliant device set, supporting up to Gigabit Ethernet. MSP 209M is supplied “ready to use”.



MG

### MSP 214 – DVI | Fiber

Delivered as a Transmitter and Receiver set, MSP214 features DVI-I connectors supporting DVI 1.0 signals up to 2560x816@60Hz, 1920x1200@60Hz (WUXGA), and 2048x1200@60Hz. HDMI signals with the use of a adapter are also supported up to HDMI 1.4. With low loss, high bandwidth 10Gbps transmission over fibre optic cable MSP214 provides solution for extended transmission of DVI.



MG

### MSP 318N – HDMI 2.0 Fiber Extender Set

The MSP 318N is an HDMI 2.0 optical fiber transmission extender consisting of a transmitter and a receiver. Equipped with corresponding SFP multi-mode fiber and single-mode 10 Gigabit fiber transmission, it can transmit the longest distance of 300M and 60KM respectively. Support 4K@60HZ (YUV4:4:4), support HDR and HDCP2.2 standards.



MG

### MSP 217 – 3G-SDI | FIBRE

For extended transmission of SDI signals the MSP 217 set of Transmitter and Receiver provide capability for high speeds over long distances with high fidelity and very low loss using fiber optic cable. This extender is suitable for SDI signals conforming to SMPTE 424, SMPTE 292M and SMPTE 259M standards, and supports high bandwidth 10Gbps transmissions at resolutions up to 3G-SDI.



### MSP 314-2 – DVI Extender

Extend 2K DVI signals via Fiber optic cable with the MSP314-2 set. This compact , transmitter receiver set plugs directly into DVI ports and is ideal for portable applications.

Integral LC ports allow connection to Fiber cables for transmission up to 300m with multi-mode Fiber or up to 2000m with single mode Fiber. The ultimate in compact signal extension, simply power MSP318-2 from supplied plug-packs.

Resolutions up to 2560x816@60Hz are supported with EDID capture available via push-pin.



### MSP 314-4 – DVI Extender

Extend DVI via Fiber optic cable with the MSP314-4 set. This compact, transmitter receiver set plug directly into DVI ports avoiding the need for additional rack space or shelving with MSP314-4 being ideal for portable applications.

MSP314-4 features integral LC ports – simply connect to a Fiber cable for transmission up to 300m with multi-mode Fiber or up to 2000m with single mode Fiber. Power MSP318-4 from supplied plug-packs.

Resolutions up to 3840x2160@30Hz are supported with EDID copy available via push-pin.

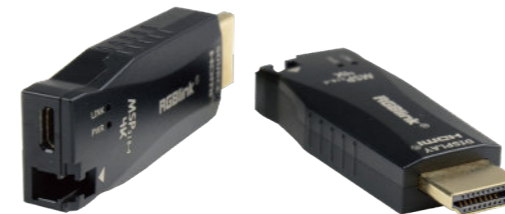

### MSP 318-4 – HDMI Extender

Extend HDMI beyond usual limits with the MSP318-4 Fiber extender set. Plug the transmitter directly into an HDMI source, and connect to either single or multi mode fiber optic cable. Similarly connect the receiver directly into an HDMI port on a display or downstream device. Just connect to low voltage power supply (included) at each end, MSP 318-4 is truly compact and ideal for portable applications or where there is restricted space.

MSP314-4 features integral LC ports – simply connect to a Fiber cable for transmission up to 300m with multi-mode Fiber or up to 2000m with single mode Fiber.

HDCP compliant, resolutions up to 3840x2160@30Hz are supported with EDID management available via microUSB.

\* MG product may be fitted into MSP Garage

## STREAMING

- CAPTURE
- SWITCHER
- ENCODER
- CLOUD/DECODER
- ASK Series Collaboration solutions

## PRO AV

- D Series Digital Processors
- X Series Universal Processors
- M Series Mixing & Scaling
- FLEX Series Mixed Signal Matrix
- Q Series FLEX multi-signal matrix

- 1 Series Switcher/Scalers

- T Series Control Consoles

- Subito Series LED Control Solutions

- UMS Series Media Solutions

- RMS Series Monitoring Solutions

- MSP Series Video Tools/Extenders Signal Converters Signal Distributors

- Accessories

- Software

- Reference

- Contact

# MSP

## Signal Convertors



MG

### MSP 203 – SDI | HDMI

Up to 3G-SDI input signals are supported on this mini convertor, with an SDI Loop port also provided. Embedded audio may also be used else audio can be inserted as separate L/R analog or as digital AES / EBU inputs. Output to HDMI can be configured as HDMI 1.3 or DVI 1.0. DIP switches provide easy on device configuration, while remote configuration by USB is also available.



MG

### MSP 204 – HDMI | SDI

Convert common HDMI signals to SDI (up to 3G-SDI). Audio can be embedded into the SDI output or muted. Audio out split is available via 1/4" mono jack connectors for either analog L/R audio or AES/EBU digital audio. On board configuration via DIP switches is available as is remote configuration over USB.



MG

### MSP 303 – SDI to HDMI Mini Converter

MSP 303 is a SDI to HDMI video converter supporting 1 x SDI input, 1 x HDMI output. SDI input resolutions available are 480i@60 | 576i | 720p@50/59.94/60 | 1080i@50/59.94/60 | 1080P@23.98/24/25/29.97/30/50/59.94/60. HDMI output resolutions supported are 720x480@60 | 720x576@60 | 1280x720@60 | 1920x1080@23.98/24/25/29.97/30/50/59.94/60.



MG

### MSP 304 – HDMI to SDI Mini Converter

MSP 304 is a HDMI to SDI video converter with one HDMI input and one SDI output. HDMI connects to sources including 720x480@60 | 720x576@60 | 1280x720@60 | 1920x1080@23.98/24/25/29.97/30/50/59.94/60, while the SDI output supports 7480i@60 | 576i | 720p@50/59.94/60 | 1080i@50/59.94/60 | 1080p@23.98/24/25/29.97/30/50/59.94/60.



MG

### MSP 305 – SDI-HDMI | HDMI-SDI Mini Converter

A 2-in-1 converter, MSP305 offers both an SDI to HDMI converter and independently an HDMI to SDI converter in one compact enclosure. Always have the conversion you need. SDI up to 3G may be input along with HDMI signals up to 2K. MSP305 makes use of a new generation of low-power demand processing, offering lower heat generation and high stability in operation and rapid conversion.



### MSP 227 – DVI Cross Converter

Convert input signal resolution for DVI output. Inputs signals supported are DVI, HDMI, VGA and YPbPr. Set the output resolution via DIP switch array. Other configurations use buttons and on screen display. Output up to 1920x1080p@60.



### MSP422 – HDMI Matrix 4K 2K Converter

Matrix HDMI 2.0 signals with this 4 in 2 out matrix or use as a 4K to 2K converter. Signals up to 4K@30Hz 4:4:4 8bit resolution are supported. MSP422 supports HDR & HDCP 2.2 and with the internal scaler, can scale 4K resolutions to 2K for output. MSP422 includes dedicated audio outputs on RCA, mini Jack and SPDIF.

\* MG product may be fitted into MSP Garage

## STREAMING

- CAPTURE
- SWITCHER
- ENCODER
- CLOUD/DECODER
- ASK Series Collaboration solutions

## PRO AV

- D Series Digital Processors
- X Series Universal Processors
- M Series Mixing & Scaling
- FLEX Series Mixed Signal Matrix
- Q Series FLEX multi-signal matrix

- 1 Series Switcher/Scalers

- T Series Control Consoles

- Subito Series LED Control Solutions

- UMS Series Media Solutions

- RMS Series Monitoring Solutions

- MSP Series Video Tools/Extenders Signal Convertors Signal Distributors

- Accessories

- Software

- Reference

- Contact

# MSP

## Signal Convertors



MG

### MSP 210D – DISPLAYPORT | SDI with Scan Converter

DisplayPort in VESA formats at 60Hz (800x600, 1024x768, 1280x720, 1280x768, 1280x800, 1280x1024, 1360x768, 1366x768, 1440x900, 1400x1050, 1600x1200, 1680x1050, 1920x1080) can be converted to SDI. L/R audio signals or AES/EBU digital audio can be inserted and embedded. SDI up to 3G-SDI is supported - scaled/scan converted outputs can be set to 480i, 576i, 720p@50Hz, 720p@60Hz, 1080i@50Hz, 1080i@60Hz, 1080p@50Hz and 1080p@60Hz. Configure by on board DIP switch or PC via USB.



MG

### MSP210V – VGA | SDI with Scan Converter

VGA in VESA formats at 60Hz (800x600, 1024x768, 1280x720, 1280x768, 1280x800, 1280x1024, 1360x768, 1366x768, 1440x900, 1400x1050, 1600x1200, 1680x1050, 1920x1080) can be converted to SDI. L/R audio signals or AES/EBU digital audio can be inserted and embedded. Up to 3G-SDI is supported - scaled/scan converted outputs can be set to 480i, 576i, 720p@50Hz, 720p@60Hz, 1080i@50Hz, 1080i@60Hz, 1080p@50Hz and 1080p@60Hz. Configure by on board DIP switch or PC via USB.



MG

### MSP 210H – HDMI | SDI with Scan Converter

Convert HDMI in VESA formats at 60Hz including 800x600, 1024x768, 1280x720, 1280x768, 1280x800, 1280x1024, 1360x768, 1366x768, 1400x1050, 1440x900, 1600x1200, 1680x1050, 1920x1080 to SDI. L/R audio signals or AES/EBU digital audio can be inserted and embedded. Up to 3G-SDI is supported - scaled/scan converted outputs can be set to 480i, 576i, 720p@50Hz, 720p@60Hz, 1080i@50Hz, 1080i@60Hz, 1080p@50Hz and 1080p@60Hz with on configuration via on board DIP switch or USB.



MG

### MSP 311 – HDMI 2.0 | Audio De-Embedder

Accepting HDMI signals up to 4K UHD, MSP311 provides separated de-embedded audio to 3.5mm stereo mini-jack and S/PDIF optical outputs allowing for the independent amplification or downstream mix of audio. Digital audio formats, including LPCM 2CH, Dolby TrueHD, Digital Plus, Atmos and DTS-HD Master Audio are supported, with audio sampling up to 192 KHz. Audio decoding selection is available from an on board switch. HDMI signals with HDR (High Dynamic Range) channels are supported and is HDCP 2.2 compliant. CEC pass-through is available too.



MG

### MSP 312 – HDMI 2.0 | DisplayPort 1.2

Convert HDMI signals up to 4K to DisplayPort with the MSP312 format converter. Input/output resolutions up to 4K2K@ 50/60hz (YUV 4:4:4) with HDR (High Dynamic Range) are supported. MS312 is HDCP 2.2 compliant. Two MSP312 may be slotted together for convenience (and used in MSP Garage), and there is an optional rack/wall mounting kit.



### MSP Garage

Mount MSP range products in the convenient MSP Garage. At 2U, the garage allows secure rack mounting up to 10 devices including space for effective heat dissipation. An integral power supply eliminates the need for individual plug-packs, improving efficiency and reliability particularly where multiple MSP are used.

## STREAMING

- CAPTURE
- SWITCHER
- ENCODER
- CLOUD/DECODER
- ASK Series Collaboration solutions

## PRO AV

- D Series Digital Processors
- X Series Universal Processors
- M Series Mixing & Scaling
- FLEX Series Mixed Signal Matrix
- Q Series FLEX multi-signal matrix
- 1 Series Switcher/Scalers
- T Series Control Consoles
- Subito Series LED Control Solutions
- UMS Series Media Solutions
- RMS Series Monitoring Solutions
- MSP Series Video Tools/Extenders Signal Convertors Signal Distributors
- Accessories
- Software
- Reference
- Contact

\* MG product may be fitted into MSP Garage

# MSP

## Signal Distributors



### MSP 316H – HDMI 2.0 Distributor

Split HDMI 2.0 signals with this 1-in-2 out compact distributor. Signals up to 4K@60 (24 bit RGB/YUV 4:4:4) including HDR signals may be connected. MSP316H has a built-in balancer, clock and driver features, LPCM 7.1CH, Dolby TrueHD and DTS-HD video and audio are supported and there is intelligent EDID recognition with standard and TV modes. Combine MSP316H in slotted pairs and there is an optional rack/wall mounting kit.



### MSP 216 – DVI

In convenient an compact format factor, MSP 216 provides simple 1-in-2 out distribution for DVI signals. MSP216 supports a wide range of resolutions up to 2160p 4K UHD, and EDID configuration can be done via USB connection to the XSET software. High quality gold plated DVI connectors are utilised and signal can be set to 8bit/10bit for HDMI support on DVI using the DIP switches.



### MSP 319 – 1x4 SDI Distributor

A high performance, high stability, high-definition SDI distributor, MSP 319 supports one SDI input and four outputs. SDI in SD-SDI, HD-SDI and 3G-SDI standards can all be used, including with embedded audio. Maximum resolution is 1080p.

MG



### MSP316D – HDMI Inline Switcher

Switch between HDMI sources with the compact MSP316 HDMI signal distributor. HDMI resolutions up to 4K DCI (4096x2160@60) with embedded audio are supported along with HDR and HDCP 1.x. Simply press the centre button to select the function.

# DXP



### DXP DP0102

DXP DP0102 is a DP 1.2 one input and two outputs video distributor, which can realize the distribution of 1 x DP1.2 input and 2 x DP1.2 output signals. It supports HDR Ycbcr:4:4:4 technology and 4Kx2K /60Hz resolution. It can be connected and extended to increase the number of display transmissions. It supports the input EDID management with two EDID modes, users can set according to the needs of the application, complete the best quality image allocation without signal loss display.



### DXP H0104

DXP H0104 is a HDMI2.0 one HDMI input and four HDMI outputs video distributor, to achieve 1 x HDMI2.0 input and 4 x HDMI2.0 output signals distribution. HDMI2.0 supports HDR Ycbcr:4:4:4 technology and 4Kx2K /60Hz resolution, HDCP2.2, 8 bits /10 bits /12 bits /36 bits /36 bits deep color. It supports input EDID management with two EDID modes, users can set according to the needs of the application, complete the best quality image allocation without signal loss display.



### DXP H0404

DXP H0404 is a 4K HD HDMI 2.0 matrix switcher. It is composed of 4 HDMI inputs and 4 HDMI outputs, forming a 4x4 matrix switcher. Each HDMI output contains 1 SPDIF audio output. It supports HDMI2.0 standard, 4kx2k@60hz 4:4:4 resolution at maximum and is compatible with HDCP2.2. It is built in intelligent EDID management with 10 types of EDID data. The device control mode is flexible and diverse, including infrared control, serial control, network control (optional), panel control and flexible control to make it more convenient to use.



### DXP D0104

DXP D0104 is a DVI one input and four outputs video distributor. Realizing 1 x DVI input and 4 x DVI output signals distribution which can be extended and increase the number of screen display, input and output support HDTV 1920x1200 (compatible with lower resolution) high resolution image allocation display.



### DXP D0108

One in eight out, the DXP D0108 provides distribution for DVI (or HDMI) signals in a reliable compact 1RU form factor. As wide range of standard VESA and SMPTE resolutions are supported, and DXP D0108 is HDCP compliant.

## STREAMING

- CAPTURE
- SWITCHER
- ENCODER
- CLOUD/DECODER
- ASK Series Collaboration solutions

## PRO AV

- D Series Digital Processors
- X Series Universal Processors
- M Series Mixing & Scaling
- FLEX Series Mixed Signal Matrix
- Q Series FLEX multi-signal matrix
- 1 Series Switcher/Scalers
- T Series Control Consoles
- Subito Series LED Control Solutions
- UMS Series Media Solutions
- RMS Series Monitoring Solutions
- MSP Series Video Tools/Extenders Signal Convertors Signal Distributors
- Accessories
- Software
- Reference
- Contact

\* MG product may be fitted into MSP Garage



# Accessories

## Flightcases



### 1U Rack Sleeves

Robust yet Lightweight protection for 1U video processors and similar equipment. Standard 19" rack included. Available with 290mm and 390mm internal depths.



### 2U Rack Sleeves

Protection for 2U video processors and similar equipment. Standard 19" rack included. Available with 320mm and 460mm internal depths.



### 4U Rack Case

Protection for 3U of 19" rack mounting equipment. Removable covers front and rear, plus heavy duty lifting handles, recessed latches and ball corners. Internal depth 550mm.



### 8U Rack Case

Protection for 7U of 19" rack mounting equipment. Removable covers front and rear, plus heavy duty lifting handles, recessed latches and ball corners. Internal depth 565mm.

## Video Cable

### DP to DP Cable



- DisplayPort 1.2 compliant
- Support 4kx2k@60Hz transmission
- Up to 21.6Gbps bit rate
- Multiple strands of 28AWG pure copper core
- 5-Layer anti- interference structure, shielding rate up to 85%
- Detachable protection caps with chain
- 50um plating connectors durable over 1000 repeated plug and unplug
- Stainless stainless screw lock
- Velcro strap for easy storage
- Synchronized audio and video lossless transmission
- Molded connectors with strain relief

### DVI to DVI Cable



- Support 3840x2160@30Hz transmission
- 2 x DVI-D male connector
- Multiple strands of 28AWG pure copper core
- 5-Layer anti- interference structure, shielding rate up to 85%
- Detachable protection caps with chain
- 50um plating connectors durable over 1000 repeated plug and unplug
- Stainless stainless screw lock
- Velcro strap for easy storage

		100±10Ω	100±10Ω
Performance	Nominal Impedance	100±10Ω	100±10Ω
	Nominal Capacitance	84±2pF/m	84±2pF/m
	Nominal Velocity of Propagation	2.38 x 105km/s	2.38 x 105km/s
	DC Resistance	195 Ω/km	195 Ω/km
	Dielectric Strength	DC500V <1min	DC500V <1min
Standard	RoHS	Yes	Yes
	Minimum Bend Radius	50mm	50mm
Environment	Working Temperature	-20 °C ~80°C	-20 °C ~80°C
	Dimensions (Net)		Connector / 42.5x40x15.6mm
Physical	Weight (Net)	2m(0.41kg) / 3m(0.59kg) /5m(0.93kg) / 7m(1.27kg) / 10m(1.79kg) / 15m(2.65kg)	2m(0.41kg) / 3m(0.59kg) /5m(0.93kg) / 7m(1.27kg) / 10m(1.79kg) / 15m(2.65kg)

### HDMI to HDMI Cable



- HDMI 2.0 compliant
- Support 4kx2k@60Hz transmission
- Up to 18Gbps bitrate
- Multiple strands of 28AWG pure copper core
- 5-Layer anti- interference structure, shielding rate up to 85%
- Detachable protection caps with chain
- 50um plating connectors durable over 1000 repeated plug and unplug
- Stainless stainless screw lock
- Velcro strap for easy storage
- Synchronized audio and video lossless transmission
- Molded connectors with strain relief

### HDMI to DVI-D Cable



- HDMI 2.0 compliant
- Support 4kx2k@60Hz transmission
- Up to 18Gbps bitrate
- Multiple strands of 28AWG pure copper core
- 5-Layer anti- interference structure, shielding rate up to 85%
- Detachable protection caps with chain
- 50um plating connectors durable over 1000 repeated plug and unplug
- Stainless stainless screw lock
- Velcro strap for easy storage
- Synchronized audio and video lossless transmission
- Molded connectors with strain relief

		100±10Ω	100±10Ω
Performance	Nominal Impedance	100±10Ω	100±10Ω
	Nominal Capacitance	84±2pF/m	84±2pF/m
	Nominal Velocity of Propagation	2.38 x 105km/s	2.38 x 105km/s
	DC Resistance	195 Ω/km	195 Ω/km
	Dielectric Strength	DC500V <1min	DC500V <1min
Standard	RoHS	Yes	Yes
	Minimum Bend Radius	50mm	50mm
Environment	Working Temperature	-20 °C ~80°C	-20 °C ~80°C
	Dimensions (Net)	Connector / 42mmx21mmx11.4mm	Connector / DVI 42.5mmx40mmx15.6mm HDMI 42mmx21mmx11.4mm
Physical	Weight (Net)	2m(0.31kg) / 3m(0.41kg) /5m(0.60kg) / 7m(0.79kg) / 10m(1.07kg) / 15m(1.53kg)	2m(0.31kg) / 3m(0.41kg) /5m(0.60kg) / 7m(0.79kg) / 10m(1.07kg) / 15m(1.53kg)

## STREAMING

CAPTURE

SWITCHER

ENCODER

CLOUD/DECODER

ASK Series  
Collaboration solutions

## PRO AV

D Series  
Digital Processors

X Series  
Universal Processors

M Series  
Mixing & Scaling

FLEX Series  
Mixed Signal Matrix

Q Series  
FLEX multi-signal matrix

1 Series  
Switcher/Scalers

T Series  
Control Consoles

Subito Series  
LED Control Solutions

UMS Series  
Media Solutions

RMS Series  
Monitoring Solutions

MSP Series  
Video Tools/Extenders  
Signal Convertors  
Signal Distributors

## Accessories

Software

Reference

Contact

### Mini DP to DP Cable



- Support for 4kx2k@60Hz transmission
- Bi-directional transmission
- 1 x Mini DisplayPort and 1 x DisplayPort connector
- Molded Connectors with strain relief
- Covers connector protection caps

Performance	Nominal Impedance	100±10Ω
	Nominal Capacitance	84±2pF/m
	Nominal Velocity of Propagation	2.38 x 105km/s
	DC Resistance	195 Ω/km
	Dielectric Strength	DC500V <1min
Standard	Voltage Rating	30V
	RoHS	Yes
Environment	Minimum Bend Radius	50mm
	Working Temperature	-20 °C ~80°C
Physical	Weight (Net)	2m / 3m /5m / 7m / 10m / 15m

### Mini DP To DVI Adapter



- Thunderbolt 2 Port Compatible
- Transmits video resolution up to 3840x2160@30
- Gold-plated connectors resist corrosion

### Mini DP to DP Adapter



- Thunderbolt 2 Port Compatible
- Synchronous transmission of 4k2k@60audio and video
- Lightweight and portable
- Gold-plated connectors resist corrosion

Connectors	Input	Mini DisplayPort Plug	Mini DisplayPort Plug
	Output	DVI 24+5 Female	DVI 24+5 Female
Performance	Input Resolution	SMPTE	720p@60 1080p@60 2160p@60
		VESA	1280x720@60   1360x768@60   1366x768@60   1600x900@60   1920x1080@60   2540x1440@60   3480x2048@60   3840x2160@60
	Output Resolution	SMPTE	720p@60 1080p@60 2160p@30
		VESA	1280x720@60   1360x768@60   1366x768@60   1600x900@60   1920x1080@60   2540x1440@60   3480x2048@30   3840x2160@30
Supported Standard	DisplayPort 1.2		
Physical	Weight	0.03kg	0.025kg
	Dimension	235+10mm	150+10mm



### Optical fiber cable

- 2/4/6/8/12 core outdoor optical fiber cable
- LC/SC/ST connectors to choose
- Multi-mold and single mode fiber to choose
- Extra wide latch for quick connection/removal
- Stainless steel metal tube ,Kevlar tensile ,stainless steel metal braiding,TPU Jacket
- G657compliant optic fiber, excellent stretchability and anti-bending feature
- TPU jacket to prevent mice biting
- Working temperature -40~80°C
- Fit for rental application
- Optional cable reel for easy storage

Connectors	Input	LC/SC/ST					
	Output	LC/SC/ST					
Performance	Tensile	Long Term	300N				
		Short Term	600N				
	Crush	Long Term	2000N/100mm				
		Short Term	3000N/100mm				
	Bending Radius	Dynamic	20D				
		Static	10D				
	Cable loss	Single Mode	1310nm	≤ 0.4db/KM			
1500nm			≤ 0.3db/KM				
Multiple Mode		850nm	≤ 0.4db/KM				
		1310nm	≤ 0.3db/KM				
Environment	Temperature	-40~80°C		-20~75°C			
Physical	No.of Fibers	2	4	6	8	12	
	Size	3.3mm	5.0mm	5.0mm	6.0mm	6.0mm	

### Mini DP to HDMI Adapter



- Synchronous transmission of 4k2k@60 audio and video
- Support high dynamic range image transmission
- HDCP 2.2 compliant
- Jitter cleaning

Connectors	Input	Mini DisplayPort	
	Output	HDMI-A Female	
Performance	Input Resolution	SMPTE	720p@60 1080p@60 2160p@60 4320p
		VESA	1280x720@60   1360x768@60   1366x768@60 1600x900@60   1920x1080@60 2540x1440@60   3480x2048@60   3840x2160@60   1920x1080@60 2540x1440@60   3480x2048@60   3840x2160@60
	Output Resolution	SMPTE	720p@60 1080p@60 2160p@60
		VESA	1280x720@60   1360x768@60   1366x768@60 1600x900@60   1920x1080@60 2540x1440@60   3480x2048@60   3840x2160@60
Supported Standard	DisplayPort 1.4		
Physical	Weight	0.025kg	
	Dimension	230x45x6mm	



### Cat5E/Cat6 Cable

- Durable break-resistant connector
- Copper terminals with anti-oxidation Nickel & Gold plating
- Easy to see florescent connector boot
- Extra wide latch for quick connection/removal
- Dual PVC jackets with high strength and heat resistance
- Pure copper wire core , each formed by 7 independent wire to conduct with low resistance
- 50um plating connectors durable over 1000 repeated plug and unplug
- Velcro strap for easy storage

		Cat5E	Cat6
Conductor	Wire Gauge	24AWG	24AWG
	Material	Bare Copper Twisted Pair	Bare Copper Twisted Pair
	Cord Size	7/0.2/BC+0.008	7/0.2/BC+0.008
Insulation	Avg.Thickness	0.19mm	0.2mm
	Min.Thickness	0.16mm	0.16mm
	Material	HD-PE	HD-PE
	Color	Orange*White/Orange, Green*White /Green, Blue*White/Blue, Brown*White/Brown	Orange*White/Orange, Green*White /Green, Blue*White/Blue, Brown*White/Brown
Jacket	Diameter	0.98+0.05mm	0.98+0.03mm
	Avg.Thickness	0.6+0.05mm	0.6+0.05mm
	Material	110P PVC	110P Matte
Physical	Diameter	6.0+0.2mm	6.0+0.015mm
		Length can be customized, up to 100 meters	1.2m / 3m /10m / 20m / 30m

### HDMI 2.0 AOC Active Optical Cable



- Up to 300m Maximum Length.(Custom Length Available)
- Low Power Consumption: 250mW (max). (No need external power)
- Plug and Play
- Compatible with HDMI 2.0 standard
- Support HDCP
- Self-detecting function for EDID information
- No loss of signal – delivering crystal clear digital images instantly
- Supports computer resolutions to 1080P and 4K2K(60P)
- Hybrid optical cable with fiber and copper wire

Cable	Hybrid Cable	4 core fiber +7 copper wires + jacket	
	Fiber	50/125 um multimode fiber	
Connectors	Input	SOURCE	HDMI-A
	Output	DISPLAY	HDMI-A
Performance	Supported Resolutions	HDMI 2.0	
		VESA	720p@60   1080p@60   2160p@60   1280x720@60   1360x768@60   1366x768@60   1600x900@60   1920x1080@60   1920x1200@60   2540x1440@60   3480x2048@60   3840x2160@60
	O/E Converter	SOURCE	4 channel 850 nm VCSEL array
		DISPLAY	4 CH GaAs PD array
	Bending Radius	52mm (min)	
	Tensile Resistance	200N (max)	
Power	Supported Standards	HDMI	2.0
		HDCP	2.2/1.4
Environment	Input Voltage	HDMI+5V(No need external power)	
	Working Current	≤45mA	
	Power Consumption	≤250mW	
Physical	Temperature	-10°C~50°C	
	Humidity	5%~90%	

### STREAMING

- CAPTURE
- SWITCHER
- ENCODER
- CLOUD/DECODER
- ASK Series Collaboration solutions

### PRO AV

- D Series Digital Processors
- X Series Universal Processors
- M Series Mixing & Scaling
- FLEX Series Mixed Signal Matrix
- Q Series FLEX multi-signal matrix
- 1 Series Switcher/Scalers
- T Series Control Consoles

- Subito Series LED Control Solutions
- UMS Series Media Solutions
- RMS Series Monitoring Solutions
- MSP Series Video Tools/Extenders Signal Convertors Signal Distributors
- Accessories
- Software
- Reference
- Contact

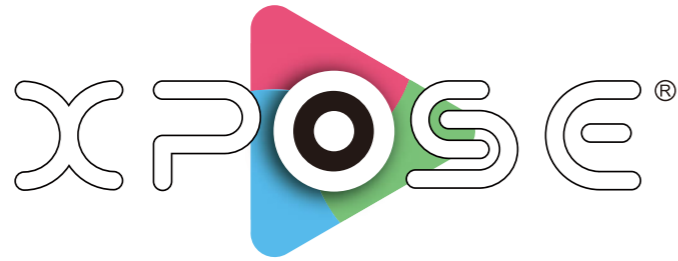

**Modern software app for universal processors and more. XPOSE redefines what control of video processors can be XPOSing advanced features with an intuitive UI so that the real power of processors across the range can be taken full advantage of.**

**Single App**

XPOSE provides remote control and configuration for all the modern RGBlink universal and presentation products. One app - XPOSE - is all that is needed from the everyday X1 to the large scale X14.

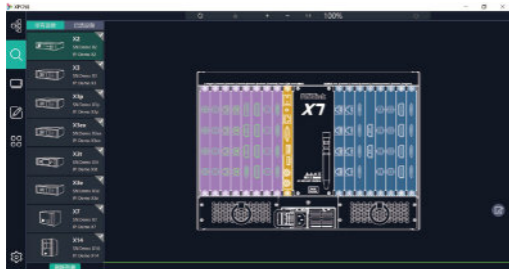

**Modern Tools**

XPOSE provides remote control and configuration in rich graphical interface that supports not only traditional mouse and keyboard, but is touch friendly too.

**Control Your Way**

Regardless of you OS favourite, Windows, macOS or Linux, there is an XPOSE edition. XPOSE, while respecting the standards on each OS platform, is the same, with a common underlying code base for enhanced compatibility and harmonisation.



**Flexible Connections**

Many of our modern products support LAN based connections. XPOSE naturally supports this mode of connectivity across either wired or wireless networks. And XPOSE also supports both USB and serial connections where those type are available on the video processor.

**Topology from Top to Bottom**

- Hands on as you open package.
- Step 1: Read In & Out out for the device once you open the package;
- Step 2: Connect inputs and outputs just like your connection;
- Step 3: Double check the connection by online synchronization;
- Step 4: Set the display area to be ready for the layers;
- Step 5: Payout by manual or schedule;
- Step 6: Monitoring all in one.

**Share Settings**

Save settings to a disk file for later recall, or sharing to other users.

**Designed for Presentation Processors**

While presentation processors have on board control with OLED displays, and large tactile buttons, there are many situations where it may be desirable to either remote control or simply create configurations from computer.

**Designed for Universal Processors**

XPOSE is the essential application for configuration of the RGBlink range of universal video processors – X series, F series, D series and so on. Whether configuration for an installation monitoring or dynamic control.



**Developing Platform**

XPOSE is under constant development, with enhancements and features regularly being added. The RGBlink team embracing DevOps to bring new releases to customers sooner.

**Virtual Canvas**

Position output displays (monitors) on a virtual canvas pixel-by-pixel. On a separate layer, then place video sources dynamically, position as required.

**4K Support**

Configuration of 4K sources is made easy with multiple configuration possibilities.



**Complex Layouts**

Sophisticated configurations are possible with not only pixel-to-pixel scaling of input sources, but also extensive output controls including advanced EDID and rotation capabilities.

**Drag 'n' Drop**

Drag and Drop both sources and output monitors onto the virtual canvas. Group sources on the canvas for ease of control and identification.

**Live Video Preview**

See preview of sources directly in XPOSE. Selected processors with H.264 IP streaming enable this features which can be a powerful monitoring tool.

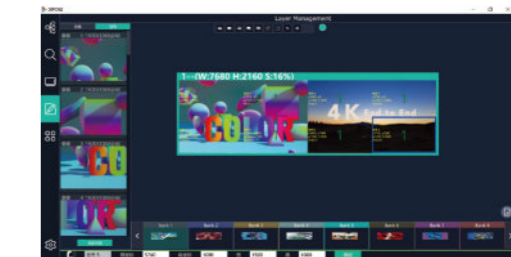

**Multi-Mode Operations**

XPOSE supports all the multi-mode operations available on the connected processor.

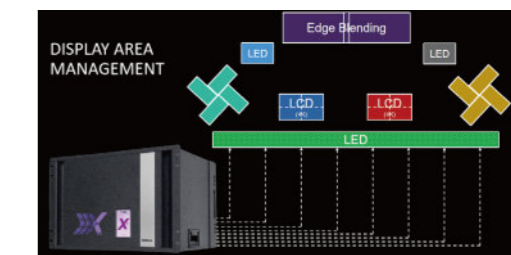

**STREAMING**

- CAPTURE
- SWITCHER
- ENCODER
- CLOUD/DECODER
- ASK Series Collaboration solutions

**PRO AV**

- D Series Digital Processors
- X Series Universal Processors
- M Series Mixing & Scaling
- FLEX Series Mixed Signal Matrix
- Q Series FLEX multi-signal matrix

- 1 Series Switcher/Scalers

- T Series Control Consoles

- Subito Series LED Control Solutions

- UMS Series Media Solutions

- RMS Series Monitoring Solutions

- MSP Series Video Tools/Extenders Signal Converters Signal Distributors

- Accessories

- Software

- Reference

- Contact



**XPOSE Mobile, fully developed in house by the RGBlink team provide a convenient remote control and configuration of universal and presentation processors.**

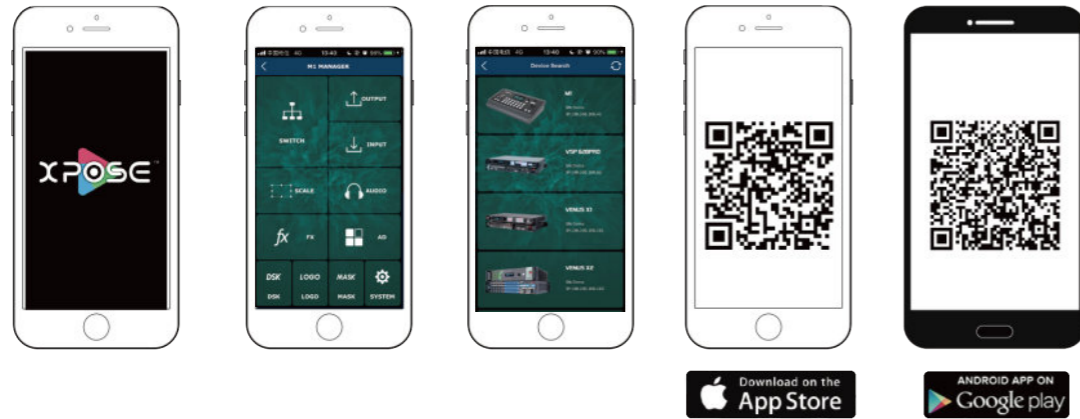

**XPOSE mini APP is a mobile version APP customized by Shicheng for the mini series. It can be completely separated from the local and computer version of XPOSE control and can quickly and easily achieve various function management applications on the mobile phone APP.**



**Configure and monitor selected MSP series products.**

**Control for MSP**

An easy to use stand-alone tool, XSET uses LAN or USB connections. Product such as the MSP225 and MSP226 can be fully configured via LAN, for example.

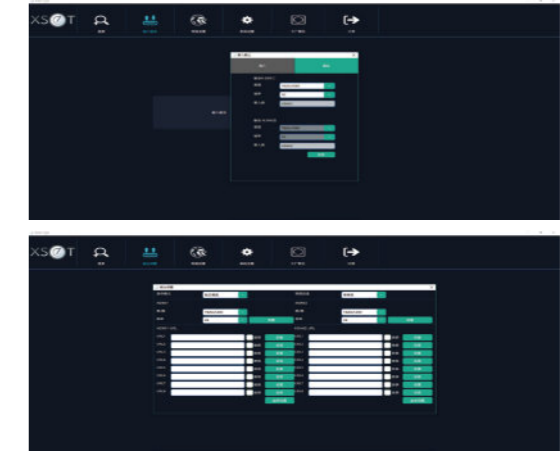

**XTOOLS is the simple and modern way to update and install features to RGBlink products.**

**Consistent Updates**

With one update package format, one app, the update process is streamlined, familiar and consistent, for greater confidence and reliability.

**Common Update Tool**

All RGBlink modern processors are updatable from XTOOLS. Simply download the update package from the website, and select the update from within XTOOLS to start.

**Review & Update**

Connect a processor to review the version status for individual components of the processor. The interface will advise differences allow clear upgrading or even downgrading. XTOOLS reports status and prompts for any actions.

**Packaged Updates**

Each update package is self contained with all necessary files. The full range of selected updates are done within XTOOLS.

**MASK**

Load and prepare MASK BMP files.

**Upload Features**

XTOOL is the app to prepare for install a range of configurable on device features, with a wizard style interface.

**OSD**

Configure OSD (On Screen Text) for loading on to products such as M2 or M3.

**STILL**

Load and prepare STILL BMP files and set transparency (alpha).

**LOGO**

Load and prepare LOGO BMP files.

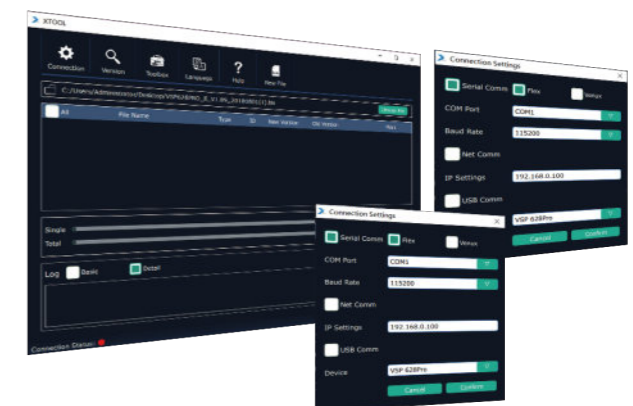

**STREAMING**

- CAPTURE
- SWITCHER
- ENCODER
- CLOUD/DECODER
- ASK Series Collaboration solutions

**PRO AV**

- D Series Digital Processors
- X Series Universal Processors
- M Series Mixing & Scaling
- FLEX Series Mixed Signal Matrix
- Q Series FLEX multi-signal matrix

- 1 Series Switcher/Scalers
- T Series Control Consoles
- Subito Series LED Control Solutions
- UMS Series Media Solutions
- RMS Series Monitoring Solutions
- MSP Series Video Tools/Extenders Signal Converters Signal Distributors
- Accessories
- Software
- Reference
- Contact

## Common Terminology

<p><b>SDI</b> Video signal standardized in SMPTE 424M that uses a single serial link at 2 Gbit/s for uncompressed transmission of video with embedded audio. Connector is BNC.</p>	<p><b>RCA</b> Connector used primarily in consumer AV equipment for both audio and video. The RCA connector was developed by the Radio Corporation of America.</p>	<p><b>Colour Temperature</b> The colour quality, expressed in degrees Kelvin (K), of a light source. The higher the colour temperature, the bluer the light. The lower the temperature, the redder the light. Benchmark colour temperature for the A/V industry include 5000°K, 6500°K, and 9000°K.</p>	<p><b>Seamless Switching</b> A feature found on many video switchers. This feature causes the switcher to wait until the vertical interval to switch. This avoids a glitch (temporary scrambling) which often is seen when switching between sources.</p>
<p><b>CVBS</b> CVBS or Composite video, is an analog video signal without audio. Most commonly CVBS is used for transmission of standard definition signals. In consumer applications the connector is typically RCA type, while in professional applications the connector is BNC type.</p>	<p><b>NTSC</b> The colour video standard used in North America and some other parts of the world created by the National Television Standards Committee in the 1950s. NTSC utilizes an interlaced video signals.</p>	<p><b>Gamma</b> The light output of a CRT is not linear with respect to the voltage input. The difference between what you should have and what is actually output is known as gamma.</p>	<p><b>Scaling</b> A conversion of a video or computer graphic signal from a starting resolution to a new resolution. Scaling from one resolution to another is typically done to optimize the signal for input to an image processor, transmission path or to improve its quality when presented on a particular display.</p>
<p><b>DVI</b> Digital Visual Interface. The digital video connectivity standard that was developed by DDWG (Digital Display Work Group). This connection standard offers two different connectors: one with 24 pins that handles digital video signals only, and one with 29 pins that handles both digital and analog video.</p>	<p><b>PAL</b> Phase Alternate Line. A television standard in which the phase of the colour carrier is alternated from line to line. It takes four full images (8 fields) for the colour-to-horizontal images (8 fields) for the colour-to-horizontal phase relationship to return to the reference point. This alternation helps cancel out phase errors. For this reason, the hue control is not needed on a PAL TV set. PAL, is widely used in Western Europe, Australia, Africa, the Middle East, and Micronesia. PAL uses 625-line, 50-field (25 fps) composite colour transmission system.</p>	<p><b>Genlock</b> Allows synchronisation of otherwise video devices. A signal generator provides a signal pulses which connected devices can reference. Also see Black Burst and Color Burst.</p>	<p><b>Saturation</b> Chroma, Chroma gain. The intensity of the colour, or the extent to which a given colour in any image is free from white. The less white in a colour, the truer the colour or the greater its saturation. Saturation is the amount of pigment in a colour, and not the intensity.</p>
<p><b>HDMI</b> High Definition Multimedia Interface: An interface used for the transmission of uncompressed high definition video, up to 8 channels of audio, and control signals, over a single cable.</p>	<p><b>SMPTE</b> Society of Motion image and Television Engineers. A global organization, based in the United States, that sets standards for baseband visual communications. This includes film as well as video and television standards.</p>	<p><b>Colour Burst</b> In colour TV systems, a burst of subcarrier frequency located on the back part of the composite video signal. This serves as a colour synchronizing signal to establish a frequency and phase reference for the Chroma signal. Colour burst is 3.58 MHz for NTSC and 4.43 MHz for PAL.</p>	<p><b>HDBaseT</b> A video standard for the transmission of uncompressed video (HDMI signals) and related features using Cat 5e/Cat6 cabling infrastructure.</p>
<p><b>DisplayPort</b> A VESA standard interface primarily for video, but also for audio, USB and other data. DisplayPort (orDP) is backwards compatible with HDMI, DVI and VGA.</p>	<p><b>VESA</b> Video Electronics Standards Association. An organization facilitating computer graphics through standards.</p>	<p><b>Contrast Ratio</b> The ratio of the high light output level divided by the low light output level. In theory, the contrast ratio of the television system should be at least 100:1, if not 300:1. In reality, there are several limitations. Well-controlled viewing conditions should yield a practical contrast ratio of 30:1 to 50:1.</p>	<p><b>HDCP</b> High-bandwidth Digital Content Protection (HDCP) was developed by Intel Corporation and is in wide use for protection of video during transmission between devices.</p>
<p><b>VGA</b> Video Graphics Array. VGA is an analog signal typically used on earlier computers. The signal is non-interlaced in modes 1, 2, and 3 and interlaced when using in mode 4.</p>	<p><b>Brightness</b> Usually refers to the amount or intensity of video light produced on a screen without regard to colour. Sometimes called —black level.</p>	<p><b>Frame</b> In interlaced video, a frame is one complete image. A video frame is made up of two fields, or two sets of interlaced lines. In a film, a frame is one still image of a series that makes up a motion image.</p>	<p><b>MPEG</b> Moving Picture Experts Group is a working group formed from ISO and IEC developing standards that allow audio/video digital compression and Transmission.</p>
<p><b>YPbPr</b> Used to describe the colour space for progressive-scan. Otherwise known as component video.</p>	<p><b>Colour Bars</b> A standard test pattern of several basic colours (white, yellow, cyan, green, magenta, red, blue, and black) as a reference for system alignment and testing. In NTSC video, the most commonly used colour bars are the SMPTE standard colour bars. In PAL video, the most commonly used colour bars are eight full field bars. On computer monitors the most commonly used colour bars are two rows of reversed colour bars.</p>	<p><b>Blackburst</b> The video waveform without the video elements. It includes the vertical sync, horizontal sync, and the Chroma burst information. Blackburst is used to synchronize video equipment to align the video output.</p>	<p><b>RTSP</b> The Real Time Streaming Protocol (RTSP) is a network control protocol designed for use in entertainment and communications systems to control streaming media servers. The protocol is used for establishing and controlling media sessions between end points.</p>
<p><b>BNC</b> Stands for Bayonet Neill-Concelman. A cable connector used extensively in television (named for its inventors). A cylindrical bayonet connector that operates with a twist-locking motion.</p>		<p><b>PIP</b> Picture-In-Picture. A small image within a larger image created by scaling down one of image to make it smaller. Other forms of PIP displays include Picture-By-Picture (PBP) and Picture- With-Picture (PWP), which are commonly used with 16:9 aspect display devices. PBP and PWP image formats require a separate scaler for each video window.</p>	<p><b>RTMP</b> Real-Time Messaging Protocol (RTMP) was initially a proprietary protocol developed by Macromedia (now Adobe) for streaming audio, video and data over the Internet, between a Flash player and a server.</p>

## STREAMING

■	CAPTURE
■	SWITCHER
■	ENCODER
■	CLOUD/DECODER
■	ASK Series Collaboration solutions

## PRO AV

■	D Series Digital Processors
■	X Series Universal Processors
■	M Series Mixing & Scaling
■	FLEX Series Mixed Signal Matrix
■	Q Series FLEX multi-signal matrix
■	1 Series Switcher/Scalers
■	T Series Control Consoles
■	Subito Series LED Control Solutions
■	UMS Series Media Solutions
■	RMS Series Monitoring Solutions
■	MSP Series Video Tools/Extenders Signal Convertors Signal Distributors
■	Accessories
■	Software
■	Reference
■	Contact

## Common Terminology

**SDVoE** Software Defined Video over Ethernet (SDVoE) is a method for transmission, distribution and management AV signals using a TCP/IP Ethernet infrastructure for transport with low latency. SDVoE is commonly used in integration applications.

**NDI** Network Device interface (NDI) is a software standard developed by NewTek to enable video-compatible products to communicate, deliver, and receive broadcast quality video in a high quality, low latency manner that is frame-accurate and suitable for switching in a live production environment over TCP (UDP) Ethernet based networks. NDI is commonly found in broadcast applications.

**ST2110** A SMPTE developed standard, ST2110 describes how to send digital video over and IP networks. Video is transmitted uncompressed with audio and other data in a separate streams. SMPTE2110 is intended principally for broadcast production and distribution facilities where quality and flexibility are more important.

**Dante AV** The Dante protocol was developed for and widely adopted in audio systems for the transmission of uncompressed digital audio on IP based networks. The more recent Dante AV specification includes support for digital video.

**H.264** Also known as AVC (Advanced Video Coding) or MPEG-4i is a common video compression standard. H.264 was standardized by the ITU-T Video Coding Experts Group (VCEG) together with the ISO/IEC JTC1 Moving Picture Experts Group (MPEG).

**H.265** Also known as HEVC (High Efficiency Video Coding) H.265 is the successor to the widely used H.264/AVC digital video coding standard. Developed under the auspices of ITU, resolutions up to 8192x4320 may be compressed.

**UHD** Standing for Ultra High Definition and comprising 4K and 8K television standards with a 16:9 ratio, UHD follows the 2K HDTV standard. A UHD 4K display has a physical resolution of 3840x2160 which is four times the area and twice both the width and height of a HDTV/FullHD (1920 x1080) video signal.

**API** An Application Programming Interface (API) provides a predefined function which allows access capabilities and features or routines via a software or hardware, without accessing source code or understanding the details of inner working mechanism. An API call may execute a function and/or provide data feedback/report.

**DMX512** The communication standard developed by USITT for entertainment and digital lighting systems. The wide adoption of the Digital Multiplex (DMX) protocol has seen the protocol used for a wide range of other devices including video controllers. DMX512 is delivered over cable of 2 twisted pairs with 5pin XLR cables for connection.

**ArtNet** An ethernet protocol based on TCP/IP protocol stack, mainly used in entertainment/events applications. Built on the DMX512 data format, ArtNet enables multiple "universes" of DMX512 to be transmitted using ethernet networks for transport.

**MIDI** MIDI is the abbreviation of Musical Instrument Digital Interface. As the name indicates the protocol was developed for communication between electronic musical instruments and latterly computers. MIDI instructions are triggers or commands sent over twisted pair cables, typically using 5pin DIN connectors.

**OSC** The principle of Open Sound Control (OSC) protocol is for networking sound synthesizers, computers, and multimedia devices for musical performance or show control. As with XML and JSON, the OSC protocol allows sharing data. OSC is transported via UDP packets between devices connected on an Ethernet network.

**HEVC** Also known as H.265, High Efficiency Video Coding (HEVC), is the successor to the widely used H.264/AVC digital video coding standard. Developed under the auspices of ITU, resolutions up to 8192x4320 may be compressed.

**EDID** Extended Display Identification Data. EDID is a data structure used to communicate video display information, including native resolution and vertical interval refresh rate requirements, to a source device. The source device will then output the provided EDID data, ensuring proper video image quality.

## Dimensions

**D6**

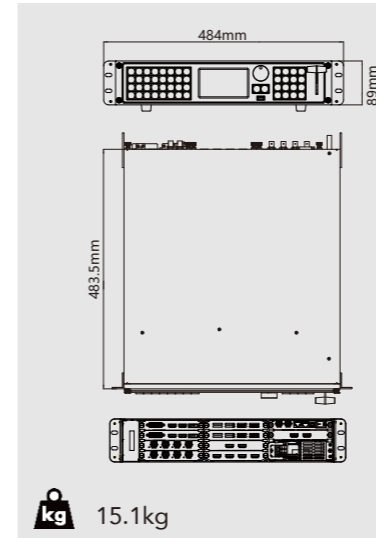

**D4**

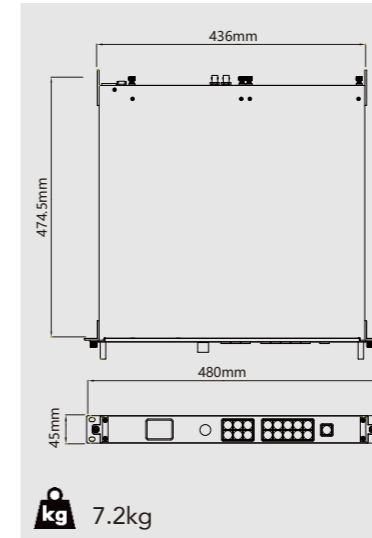

**VSP628pro**

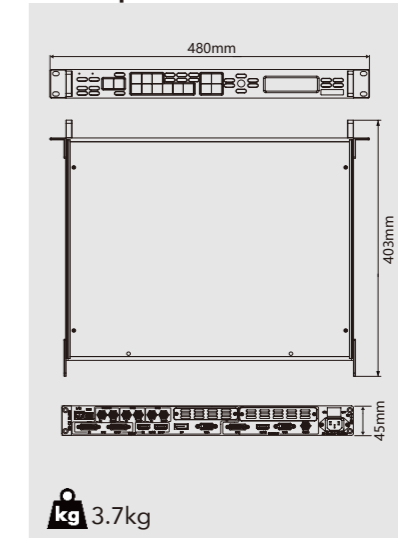

**X14**

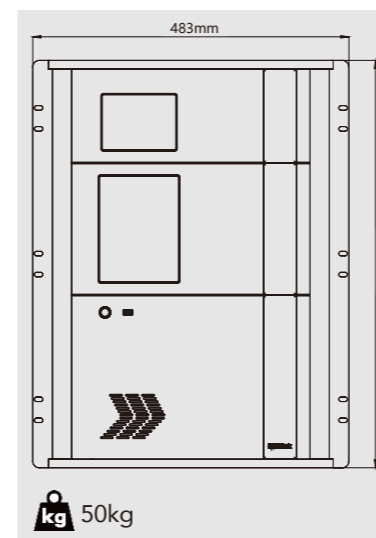

**X7**

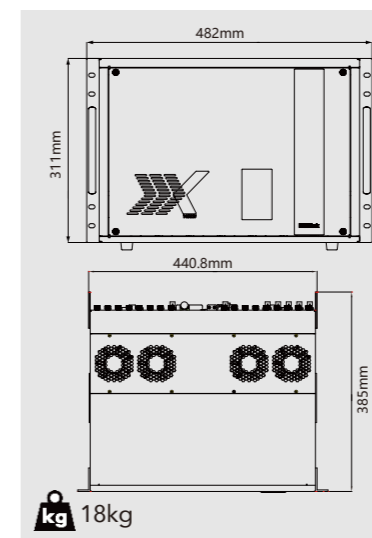

**X3**

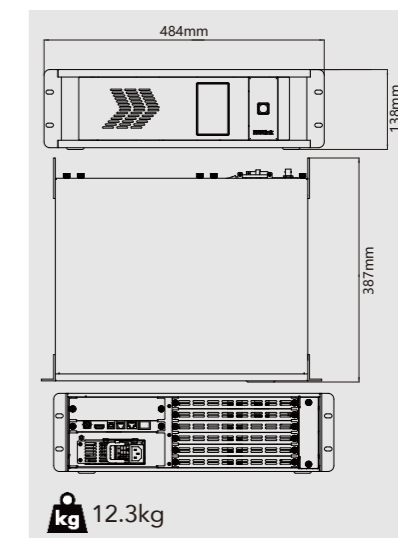

**X2**

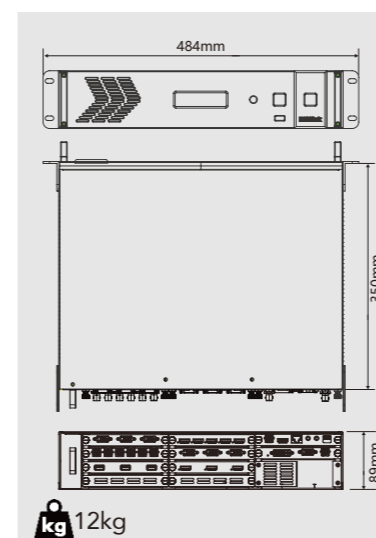

**M3**

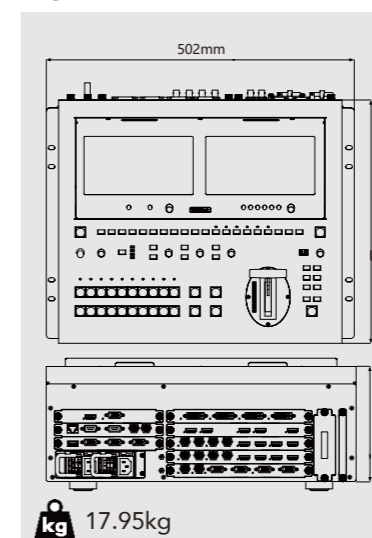

**M2**

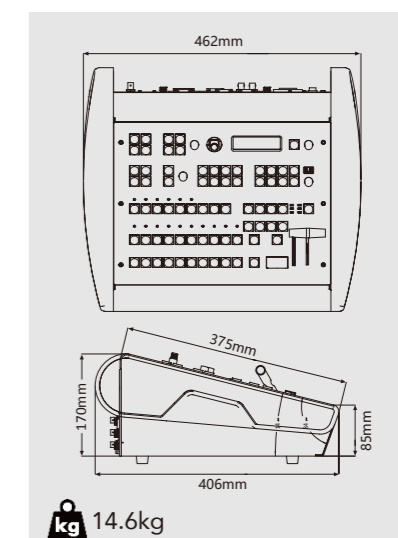

## STREAMING

- CAPTURE
- SWITCHER
- ENCODER
- CLOUD/DECODER
- ASK Series Collaboration solutions

## PRO AV

- D Series Digital Processors
- X Series Universal Processors
- M Series Mixing & Scaling
- FLEX Series Mixed Signal Matrix
- Q Series FLEX multi-signal matrix
- 1 Series Switcher/Scalers
- T Series Control Consoles
- Subito Series LED Control Solutions
- UMS Series Media Solutions
- RMS Series Monitoring Solutions
- MSP Series Video Tools/Extenders Signal Convertors Signal Distributors
- Accessories
- Software
- Reference
- Contact

**M1**

482mm  
280mm  
95mm

**kg** 5.5kg

**FLEX pro8**

484mm  
133.5mm  
458mm

**kg** 12.3kg

**FLEX RS1**

480mm  
438mm  
404mm

**kg** 2.5kg

**T1**

591.3mm  
218mm  
591.3mm

**kg** 19.2kg

**GX4**

480mm  
250mm  
45mm

**kg** 3.1kg

**FLEX 4ml**

442mm  
454mm  
484mm  
88.6mm

**kg** 9.5kg

**FLEX 8**

484mm  
462.8mm

**kg** 2.5kg

**FLEX 16**

454mm  
442.6mm  
420mm

**kg** 8.05kg

**mini/mini+**

48mm  
40.2mm  
40.2mm

**kg** 0.6kg

**G3 NET 2K**

480mm  
349mm  
45mm

**kg** 3.3kg

**UMS4**

484mm  
179mm  
45mm

**kg** 17.7kg

**RMS-1A**

205mm  
128mm  
37.5mm

**kg** 2.5kg

**UMS4**

480mm  
45mm

**kg** 15kg

**X1 proe**

480mm  
432mm  
264mm

**kg** 2.7kg

**X1**

480mm  
303mm  
432mm  
45mm

**kg** 3.5kg

**RMS 8424 | RMS 8424S**

482mm  
171.9mm  
45mm

**kg** 3/3.2kg

**RMS 5533 | RMS 5533S**

480mm  
129mm  
45mm

**kg** 2.5/2.7kg

**RMS 1516**

372mm  
20.4mm  
362mm  
200.5mm

**kg** 2.03kg

- STREAMING**
- CAPTURE
  - SWITCHER
  - ENCODER
  - CLOUD/DECODER
  - ASK Series Collaboration solutions
- PRO AV**
- D Series Digital Processors
  - X Series Universal Processors
  - M Series Mixing & Scaling
  - FLEX Series Mixed Signal Matrix
  - Q Series FLEX multi-signal matrix
  - 1 Series Switcher/Scalers
  - T Series Control Consoles
  - Subito Series LED Control Solutions
  - UMS Series Media Solutions
  - RMS Series Monitoring Solutions
  - MSP Series Video Tools/Extenders Signal Convertors Signal Distributors
  - Accessories
  - Software
  - Reference
  - Contact

RMS 4542S

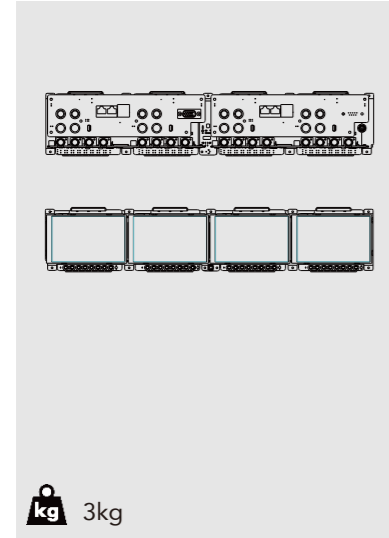

kg 3kg

MSP 200PRO

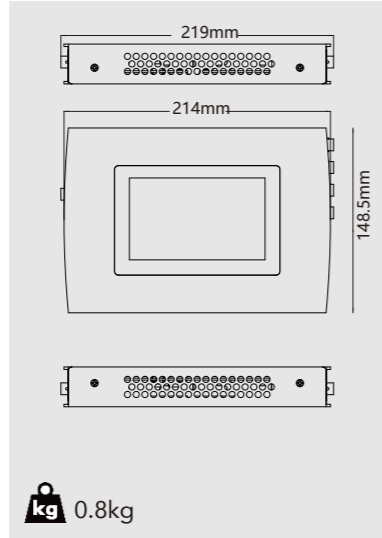

kg 0.8kg

MSP 321

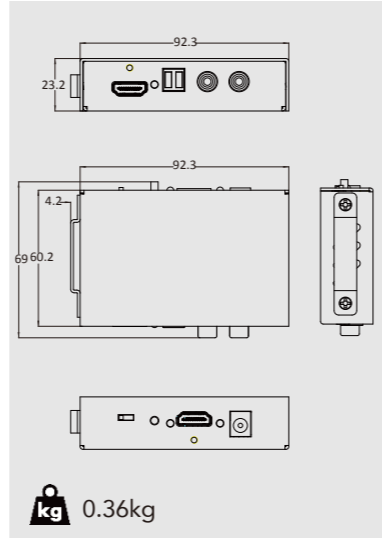

kg 0.36kg

MSP 221 | MSP 219  
MSP 203 | MSP 204

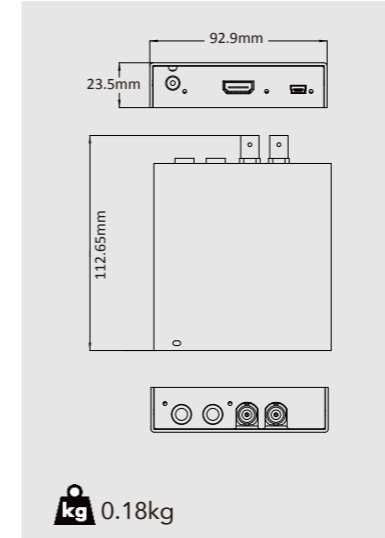

kg 0.18kg

MSP 314-2

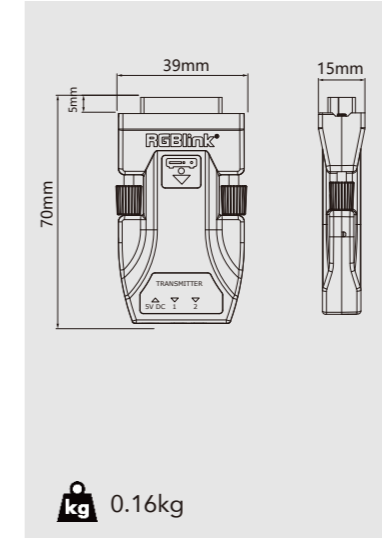

kg 0.16kg

MSP 314-4

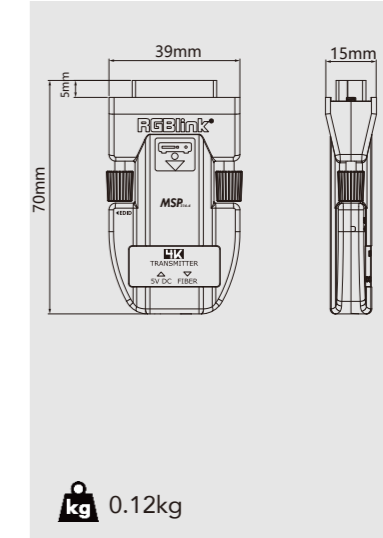

kg 0.12kg

MSP 325

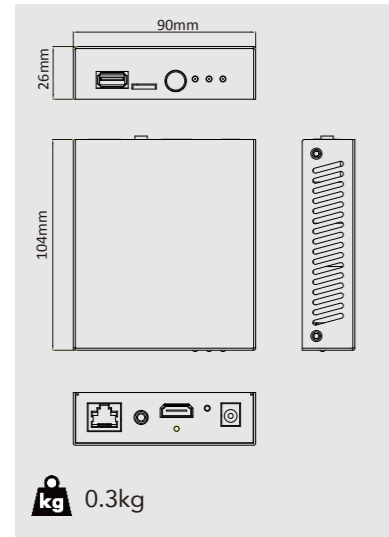

kg 0.3kg

MSP 326

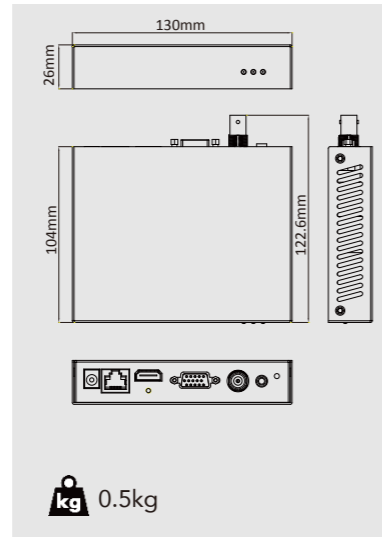

kg 0.5kg

MSP 210 | MSP 225 | MSP 226

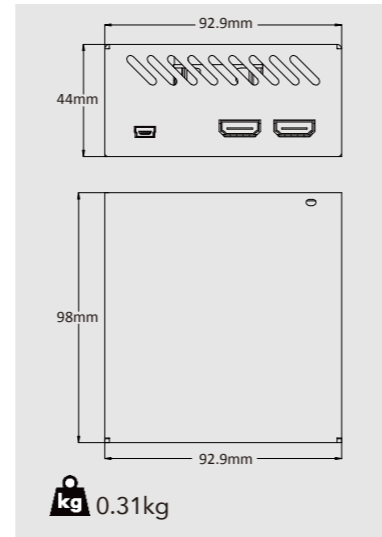

kg 0.31kg

MSP 318-4

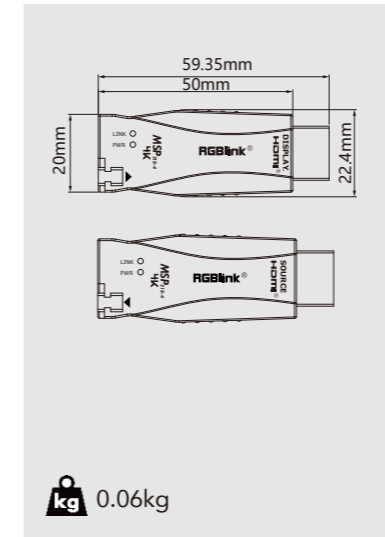

kg 0.06kg

MSP 303 | MSP 304

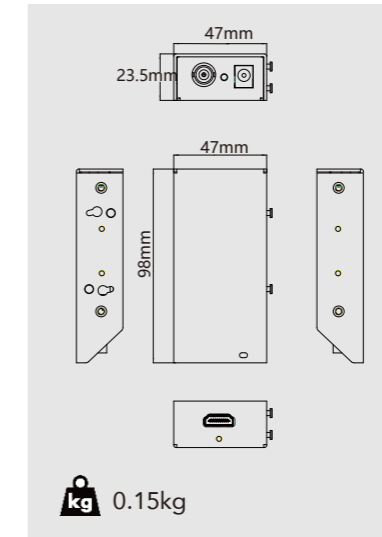

kg 0.15kg

MSP 318

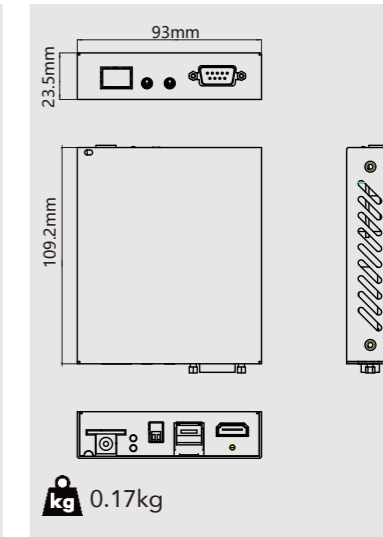

kg 0.17kg

MSP 329

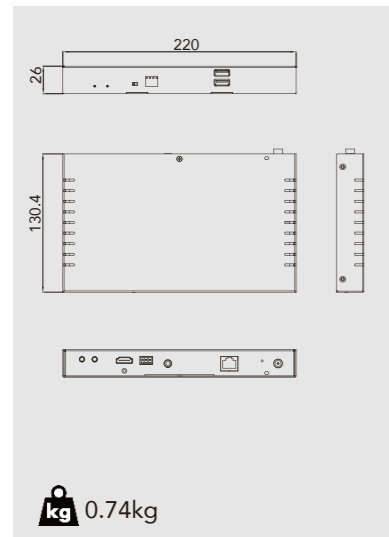

kg 0.74kg

MSP 415

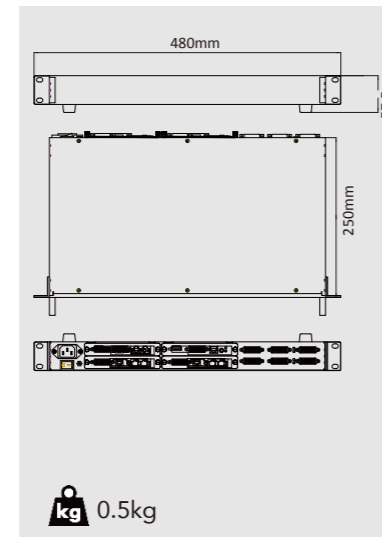

kg 0.5kg

MSP 215 | MSP 214  
MSP 209 | MSP 217

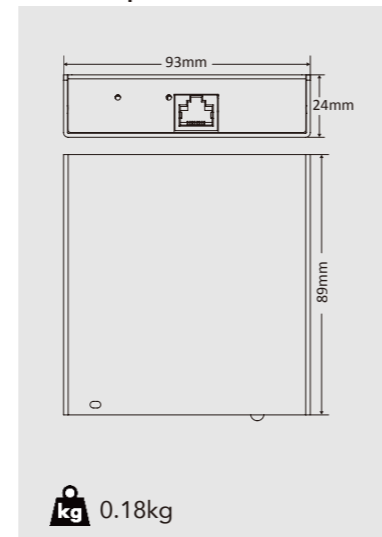

kg 0.18kg

MSP 422

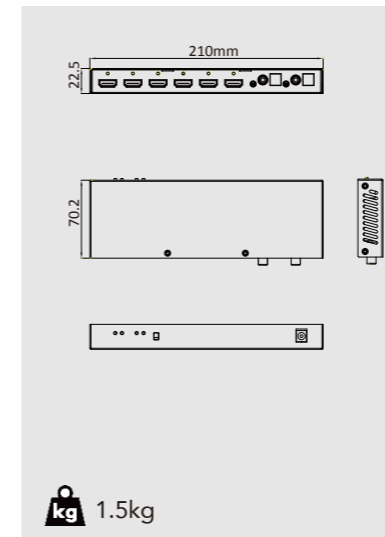

kg 1.5kg

MSP 227

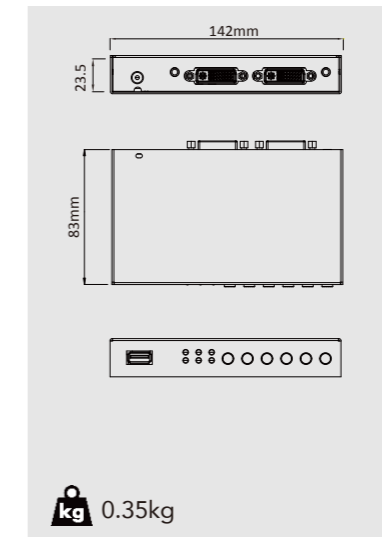

kg 0.35kg

DXP H0108

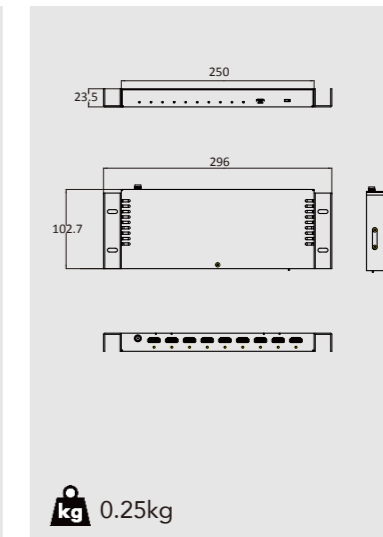

kg 0.25kg

STREAMING

- CAPTURE
- SWITCHER
- ENCODER
- CLOUD/DECODER
- ASK Series Collaboration solutions

PRO AV

- D Series Digital Processors
- X Series Universal Processors
- M Series Mixing & Scaling
- FLEX Series Mixed Signal Matrix
- Q Series FLEX multi-signal matrix
- 1 Series Switcher/Scalers
- T Series Control Consoles
- Subito Series LED Control Solutions
- UMS Series Media Solutions

RMS Series Monitoring Solutions

- MSP Series Video Tools/Extenders Signal Convertors Signal Distributors

Accessories

Software

Reference

Contact

MSP 305

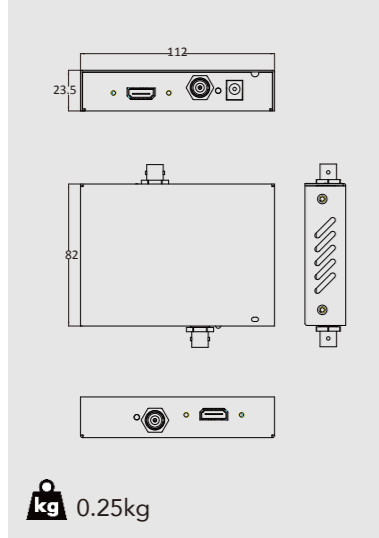

MSP 311

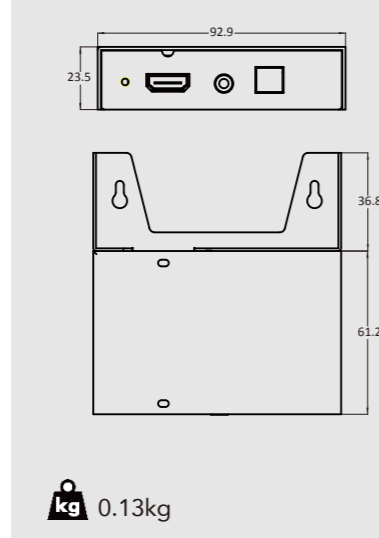

MSP 312

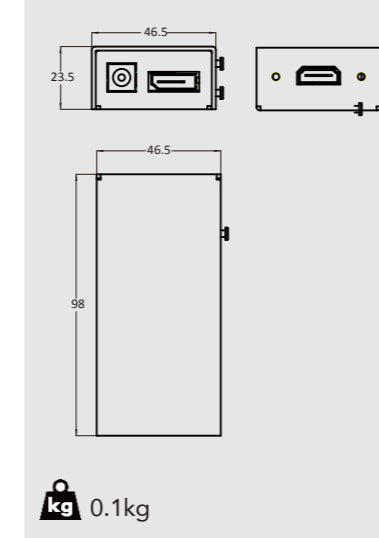

ASK Pro

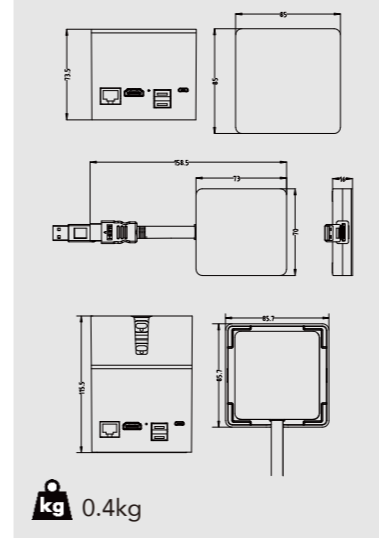

ASK nano

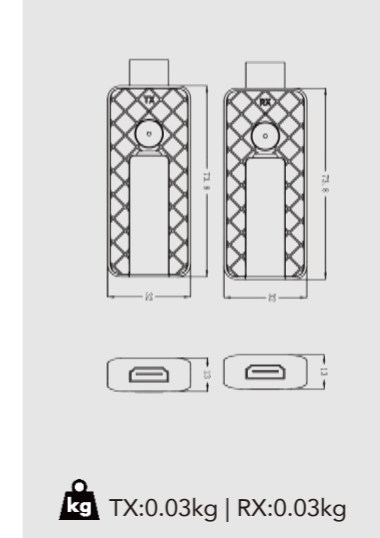

Q4L

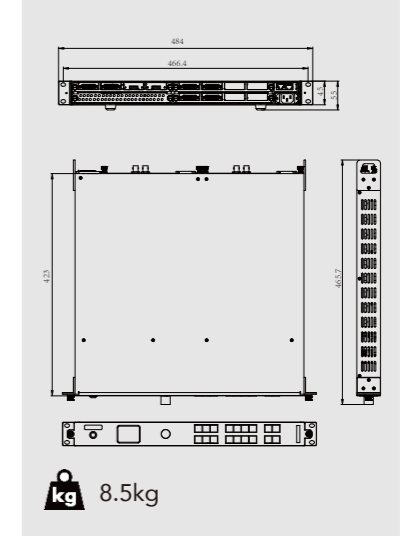

MSP 316H

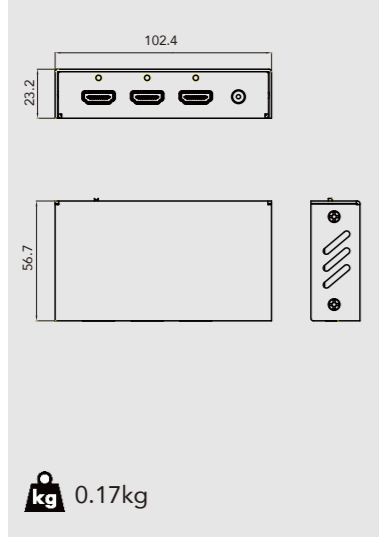

MSP 316D

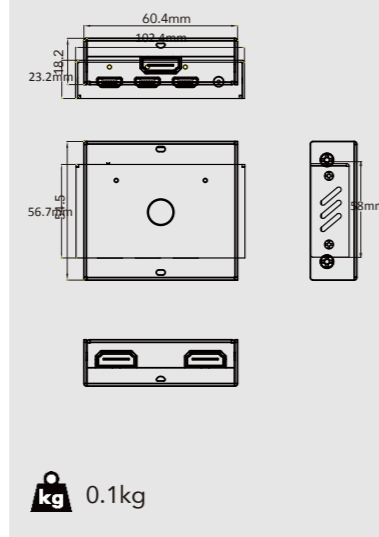

MSP 216

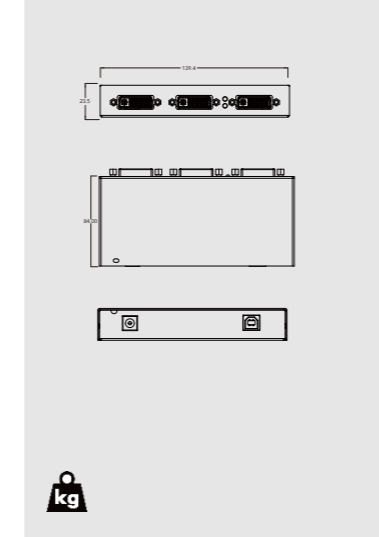

Q16

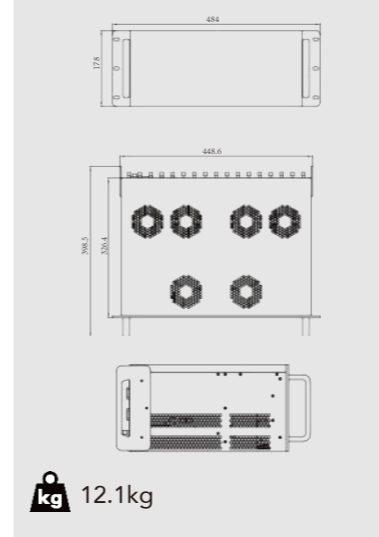

MSP 319

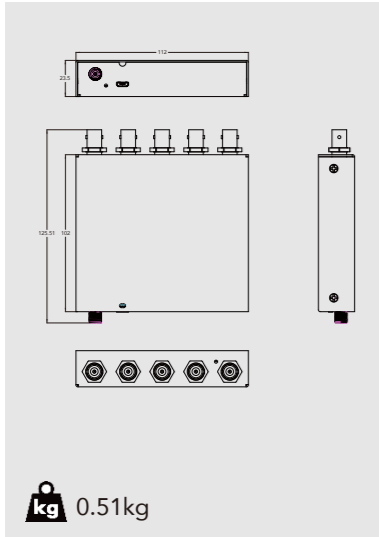

DXP DP0102

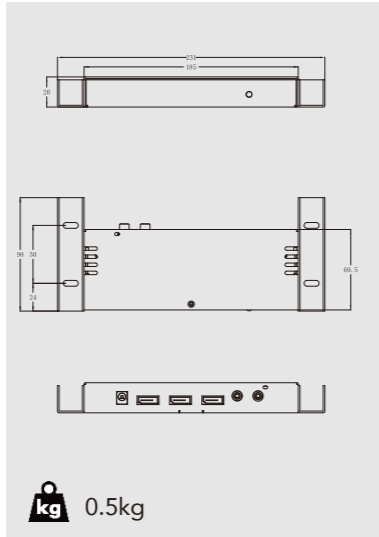

DXP H0104

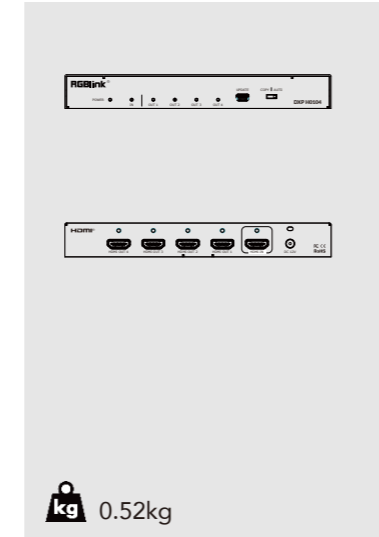

STREAMING

- CAPTURE
- SWITCHER
- ENCODER
- CLOUD/DECODER
- ASK Series Collaboration solutions

PRO AV

- D Series Digital Processors
- X Series Universal Processors
- M Series Mixing & Scaling
- FLEX Series Mixed Signal Matrix
- Q Series FLEX multi-signal matrix
- 1 Series Switcher/Scalers
- T Series Control Consoles
- Subito Series LED Control Solutions
- UMS Series Media Solutions
- RMS Series Monitoring Solutions
- MSP Series Video Tools/Extenders Signal Converters Signal Distributors
- Accessories
- Software
- Reference
- Contact



## Collaboration Solutions

Product Code	Item	Description
450-1001-01-0	ASK Pro Set	2×TX(Ask me)+1×RX (Ask mini)
450-1004-01-0	ASK nano Meet Set	2×nano TX+1×nano RX

## All-In One Scaling & Maxing

Product Code	Item	Description
310-0003-31-1	M3	Presentation Processor and Vision Mixer with HDMI PGM/PST & PVW Modules, with Tally/USB Config Module with Flightcase Input & AUX Output modules sold separately
210-3072-12-0	M2	Scaler & Vision Mixer with 3 pieces EXT fitted with PGM/PST, with PVW/Tally Module with Flightcase Input modules sold separately
220-0001-01-0	M1	Scaler & Vision Mixer with EXT4 Input & Output modules sold separately (cardboard carton packaged)
230-0001-01-0	mini	2K 4X1 HDMI mini switcher support audio input and output USB 3.0 streaming output 6-picture preview
230-0001-02-0	mini+	mini with features of logo Chroma Key and PTZ control

## Universal Processors

Product Code	Item	Description
310-0014-01-0	X14	56x40 Universal Processor with 1 Power Supply fitted Input & Output modules sold separately.
310-0007-00-0	X7	32x32 Universal Processor with 1 Power Supply fitted Input & Output modules sold separately.
110-0003-41-0	X3	16x8 Universal Processor with 1 Power Supply fitted Preview Module sold separately Input & Output modules sold separately.
310-0002-01-0	X2	16x16 Universal Processor with Streaming Output Preview Module Input & Output modules sold separately.

## Presentation Processors

Product Code	Item	Description
120-0004-01-0	D4	4K Dual Channel Presentation Processor With HDMI 2.0 and Comm Output Module Other inputs and outputs are optional
100-0628-03-0	VSP628pro	2K Dual Channel Professional Presentation Switcher
110-0628-01-0	D6	4K Multi Channel Presentation Switcher with 1 Power Supply fitted with Preview (PVW) Module HDMI fitted Input & Output modules sold separately

## Switcher/Scalers

Product Code	Item	Description
110-0001-02-2	X1	2K Scaler & Switcher with EXT3 fitted
110-0001-10-0	X1pro EXT	4K Scaler & Switcher with EXT3 fitted

## Media Solutions

Product Code	Item	Description
820-0001-01-0	UMS 4	Universal Media Server hardware. BYO operating system Inputs capture by optional input modules 4K Outputs by optional output modules

## Remote Control Consoles

Product Code	Item	Description
250-0001-01-0	T1	Control Console for universal processors
250-1000-01-0	Tgo	Control surface with desktop and rack accessory

## Preview Monitors

Product Code	Item	Description
400-8424-01-0	RMS8424	Dual LCD Monitors with CVBS/DVI/VGA/HDM
410-8424-01-0	RMS1A	Single 8.4in Display block with DVI-I Input DVI/VGA/HDMI and USB input
400-1516-01-0	RMS1516	Single 15 inch display with 1 HDMI 2.0 input, 3 HDMI 1.3 inputs, 1 3G/HD/SD SDI input, 1 DVI input, 1 VGA input

## Videowall Control

Product Code	Item	Description
790-1001-28-0	FLEXpro 8	16x8 Universal Processor with single Power Supply fitted Input & Output modules sold separately.
700-0001-01-0	FLEX RS1	Rotation/Blending/Splicing Processor with 4K input & 4x2K DVI Outputs
710-0008-00-0	FLEX 8	8x8 Matrix Processor EXT sold separately Input & Output modules sold separately
710-0016-00-0	FLEX 16	16x16 Matrix Processor EXT sold separately Input & Output modules sold separately
710-0004-02-0	FLEX4ml	with a 4K2K@60 input module, and 4 DVI output modules and 2 EXT output modules as standard, other modules are optional

## Hyper Multiwindow Video Wall Processor

Product Code	Item	Description
711-0016-00-0	Q16 4U Universal Processor	Max 16x16 Universal Processor with Power Supply fitted Input & Output modules sold separately. 4 Unit size. Max support 8 input modules and 8 output modules

## STREAMING

- CAPTURE
- SWITCHER
- ENCODER
- CLOUD/DECODER

ASK Series  
Collaboration solutions

## PRO AV

D Series  
Digital Processors

X Series  
Universal Processors

M Series  
Mixing & Scaling

FLEX Series  
Mixed Signal Matrix

Q Series  
FLEX multi-signal matrix

1 Series  
Switcher/Scalers

T Series  
Control Consoles

Subito Series  
LED Control Solutions

UMS Series  
Media Solutions

RMS Series  
Monitoring Solutions

MSP Series  
Video Tools/Extenders  
Signal Converters  
Signal Distributors

Accessories

Software

Reference

Contact

## Matrix

Product Code	Item	Description
500-0404-01-0	DXPD0404	4x4 DVI Matrix
500-0808-01-0	DXPD0808	8x8 DVI Matrix
500-1616-01-0	DXPD1616	16x16 DVI Matrix
500-0108-01-0	DXPD0108	1x8 DVI Distributor
621-1104-01-0	DXPD0104	1x4 DVI Distributor
621-2104-01-0	DXPH0108	1x8 HDMI Distributor HDMI 2.0 and HDCP 2.2 Compatible
551-0104-01-0	DXPH0104	1x4 HDMI 2.0 Distributor
621-3102-01-0	DXPDP0102	1x2 DP1.2 Distributor with 1 pair S/PDIF audio output
621-4104-01-0	DXPH0404	4x4 HDMI 2.0 Matrix
552-1616-01-0	DXPH1616	16x16 HDMI 1.3 Matrix
510-0808-01-0	DXPA0808	8x8 Composite Matrix
510-1616-01-0	DXPA1616	16x16 Composite Matrix
520-0808-01-0	DXPV0808	8x8 VGA Matrix
520-1616-01-0	DXPV1616	16x16 VGA Matrix
552-1010-01-0	DXPH1010 HDMI 2.0 Matrix	10x10 HDMI 2.0 Matrix with 4K60Hz

## Mini (MSP) Series-Testing Tools & Convertors

Product Code	Item	Description
650-0200-01-0	MSP200PRO	Signal & Test Pattern Generator with Plug Pack with ABS Protective Case SDI input module sold separately Batteries sold separately
650-0221-01-0	MSP221	EDID Manager
600-0227-01-0	MSP227	DVI Cross Convertor supports AV/YPbPr/VGA/HDMI/DVI
600-0203-01-0	MSP203	SDI to HDMI Convertor with Audio Embedded
601-0203-01-0	MSP303	SDI to HDMI Convertor without Audio Embedded
600-0204-01-0	MSP204	HDMI to SDI Convertor with Audio Embedded
601-0204-01-0	MSP304	HDMI to SDI Convertor without Audio Embedded
600-0210-05-0	MSP210V	VGA to SDI Convertor with Scan Convertor & Scaler
600-0210-04-0	MSP210H	HDMI to SDI Convertor with Scan Convertor & Scaler
600-0210-02-0	MSP210C	Composite to SDI Convertor with Scan Convertor & Scaler
600-0210-03-0	MSP210D	Display Port to SDI Convertor with Scan Convertor & Scaler
601-0422-01-0	MSP422	HDR 10 and Dolby Vision HDR 4 HDMI 2.0 inputs and 2 HDMI 2.0 outputs 4 in 2 out matrix or 4 in 2 out converter
621-0321-01-0	MSP321	HDMI 2.0 input analyser, EDID Manager & HDCP Toolbox and Pattern Generator

## Mini (MSP) Series-Distributors

Product Code	Item	Description
620-0216-01-0	MSP216	1 DVI In/2 DVI Out Distributor
621-0219-04-0	MSP319	1 SDI In/4 SDI Out Distributor
920-0005-01-0	MSP Garage with PSU	Rack frame for MSP products with integrated power management
621-0316-02-0	MSP316	1 HDMI2.0 In/2 HDMI2.0 Out Splitter or 2 HDMI 2.0 In/1 HDMI 2.0 Out
621-0316-01-0	MSP316H	HDMI 2.0 1x2 Splitter

## Mini (MSP) Series-Extenders

Product Code	Item	Description
610-0209-01-2	MSP209S	Ethernet to Single Mode Fiber Extender Set
610-0209-02-2	MSP209M	Ethernet to Multi Mode Fiber Extender Set
610-0214-01-2	MSP214	HDMI/DVI to Fiber Extender Set <i>without SFP Module – refer Options</i>
610-0217-01-0	MSP217	SDI to Fiber Extender <i>without SFP Module – refer Options</i>
610-0215-01-2	MSP215	HDBaseT HDMI to Cat5e/6 Extender Set <i>(max 100m) , supports 4K@30</i>
611-0315-01-0	MSP315	HDBaseT HDMI to Cat5e/6 Extender Set <i>(max 100m) , with POE, supports 4K@30</i>
600-0225-01-1	MSP225	HDMI / H.264 Streaming Encoder
600-0226-01-1	MSP226	HDMI / H.264 Streaming Decoder
611-0001-01-0	MSP314-2	2K@60 HDMI/DVI Fiber converter, for 2 Fiber Set
611-0011-01-0	MSP314-4	4K@30 HDMI/DVI Fiber converter, for 1 Fiber Set
611-0012-01-0	MSP318-4	4K@60 HDMI/DVI Fiber converter (YUV 420), for 1 Fiber Set
920-0001-01-0	DVI-I Inline Active Extender	With DVI female input and DVI female output
920-0002-01-0	HDMI A Inline Active Extender	With HDMI demale input and HDMI female output
611-0415-01-0	MSP415 Tx	HDBaseT HDMI 2.0 to Cat6 Extender HDMI, IR, Remote Power Extension up to 65m, 4K@60
611-0415-01-1	MSP415 Rx	HDBaseT Cat6 to HDMI Extender HDMI, IR, Remote Power Extension up to 65m, 4K@60
601-0325-01-0	MSP325	HDMI 1.4 to H.265 Streaming Encoder Single Channel
601-0325-01-0	MSP326	H.265 to HDMI 1.4 Streaming Decoder Single Channel
611-0329-01-0	MSP 329 Tx	HDMI 1.4 to Ethernet and Fiber with KVM
611-0329-01-1	MSP 329 Rx	HDMI 1.4 to Ethernet and Fiber with KVM

## LED Control Solutions

Product Code	Item	Description
820-1004-02-0	GX4	Scaler & Switcher with RGBlink Subito build in
820-2004-01-0	Subito sender box	Integrated Subito Quatro Sender/Controller with USB and HDMI inputs
790-1001-28-0	Subito sender card	LED Control Module for Processors /Gigabit 4xRJ45 port sender card
850-2001-01-0	Subito Receiver Card-Apollo 2001	Four 26-core bovine needle output, reverse welding
850-2002-01-0	Subito Receiver Card-Apollo 2002	Four 26-core bar outputs, reverse welding
850-2100-01-0	Subito Receiver Card-Aries 2100	Two 60-core bovine needle output, reverse weld
850-1200-01-0	Subito Receiver Card-Eos 1200	Two 50 core standard interfaces
850-1000-01-0	Subito Receiver Card-Eos 1000	12 HUB75 interface general receiver card
850-1100-01-0	Subito Receiver Card-Eos 1100	16 HUB75 interface conventional receiver card
850-3000-01-0	Subito Receiver Card-Leo 3000	Double 120 core high density interface receiver card
850-2000-01-0	Subito Receiver Card-Apollo 2000	Four 26-core bovine needle output, front weldingNOVAStar: MRV210/ MRV410 Colorlight:i5A-907 Linsn: RV907H/ RV927H/ RV937H

STREAMING

CAPTURE

SWITCHER

ENCODER

CLOUD/DECODER

ASK Series  
Collaboration solutions

PRO AV

D Series  
Digital Processors

X Series  
Universal Processors

M Series  
Mixing & Scaling

FLEX Series  
Mixed Signal Matrix

Q Series  
FLEX multi-signal matrix

1 Series  
Switcher/Scalers

T Series  
Control Consoles

Subito Series  
LED Control Solutions

UMS Series  
Media Solutions

RMS Series  
Monitoring Solutions

MSP Series  
Video Tools/Extenders  
Signal Convertors  
Signal Distributors

Accessories

Software

Reference

Contact

## Flightcases

Product Code	Item	Description
900-0001-01-0	1RU	1U 19in Rack Sleeve 490mm
900-0001-02-0	1RU	1U 19in Rack Sleeve 590mm
900-0002-01-0	2RU	2U 19in Rack Sleeve 490mm
900-0002-02-0	2RU	2U 19in Rack Sleeve 590mm
900-0006-01-0	6RU	6U 19in Rack Sleeve
900-0008-01-0	8RU	8U 19in Rack Sleeve
900-0012-01-0	12RU	12U 19in Rack Sleeve
900-1001-01-0	168RU1	1U for 2 units VSP168
900-1002-01-0	168RU2	2U for 4 units VSP168
911-0100-01-0	Cable Reel	for Fiber Optical Cable length max 150 meters
911-0150-01-0	Cable Reel	for Fiber Optical Cable length max 250 meters
911-0250-01-0	Cable Reel	for Fiber Optical Cable length max 400 meters

## Cables

Product Code	Item	Description
921-0002-01-0	DVI-DVI Cable	with protection caps,3840 x 2160@30 2 meters
921-0003-01-0	DVI-DVI Cable	with protection caps,3840 x 2160@30 3meters
921-0005-01-0	DVI-DVI Cable	with protection caps,3840 x 2160@30 5 meters
921-0010-01-0	DVI-DVI Cable	with protection caps,3840 x 2160@30 10 meters
921-0015-01-0	DVI-DVI Cable	with protection caps,3840 x 2160 @30 15meters
922-0002-01-0	DVI-HDMI Cable	with locking HDMI and protection caps,3840 x 2160@30, 2 meters
922-0003-01-0	DVI-HDMI Cable	with locking HDMI and protection caps,3840 x 2160@30, 3 meters
922-0005-01-0	DVI-HDMI Cable	with locking HDMI and protection caps,3840 x 2160@30, 5meters
922-0010-01-0	DVI-HDMI Cable	with locking HDMI and protection caps,3840 x 2160@30, 10 meters
922-0015-01-0	DVI-HDMI Cable	with locking HDMI and protection caps,1920*1080@30, 15meters
923-0002-01-0	HDMI-HDMI Cable	with locking HDMI and protection caps,3840 x 2160@60, 2 meters
923-0003-01-0	HDMI-HDMI Cable	with locking HDMI and protection caps,3840 x 2160@60, 3 meters
923-0005-01-0	HDMI-HDMI Cable	with locking HDMI and protection caps,3840 x 2160@60, 5meters
923-0010-01-0	HDMI-HDMI Cable	with locking HDMI and protection caps,3840 x 2160@30, 10 meters
923-0015-01-0	HDMI-HDMI Cable	with locking HDMI and protection caps, 3840 x 2160@30, 15 meters
924-0002-01-0	DP-DP Cable	with protection caps,3840 x 2160@60 2 meters
924-0003-01-0	DP-DP Cable	with protection caps,3840 x 2160@60 3meters
924-0005-01-0	DP-DP Cable	with protection caps,3840 x 2160@60 5 meters

Product Code	Item	Description
924-0015-01-0	DP-DP Cable	with protection caps,1920*1080 @60 15meters
925-0002-01-0	DP-DVI Cable	with protection caps,3840 x 2160@30 2 meters
925-0005-01-0	DP-DVI Cable	with protection caps,3840 x 2160@30 5 meters
926-0002-01-0	Mini DP-DP Cable	with protection caps,3840 x 2160@60, 2 meters
926-0003-01-0	Mini DP-DP Cable	with protection caps,3840 x 2160@60, 3 meters
926-0005-01-0	Mini DP-DP Cable	with protection caps,3840 x 2160@60, 5 meters
927-0002-01-0	Mini DP-DVI Cable	with protection caps,3840 x 2160@60 2 meters
927-0003-01-0	Mini DP-DVI Cable	with protection caps,3840 x 2160@60 3meters
927-0005-01-0	Mini DP-DVI Cable	with protection caps,3840 x 2160@30 5 meters
928-0002-01-0	Mini DP-HDMI Cable	with locking HDMI and protection caps,3840 x 2160@60, 2 meters
928-0003-01-0	Mini DP-HDMI Cable	with locking HDMI and protection caps,3840 x 2160@60, 3 meters
928-0005-01-0	Mini DP-HDMI Cable	with locking HDMI and protection caps,3840 x 2160@60, 5 meters
931-0100-01-0	Fiber - Single Mode	with protection caps, 2 cores inside, LC to LC connector, 100m
931-0150-01-0	Fiber - Single Mode	with protection caps, 2 cores inside, LC to LC connector, 150m
931-0200-01-0	Fiber - Single Mode	with protection caps, 2 cores inside, LC to LC connector, 200m
931-0250-01-0	Fiber - Single Mode	with protection caps, 2 cores inside, LC to LC connector, 250m
931-0300-01-0	Fiber - Single Mode	with protection caps, 2 cores inside, LC to LC connector, 300m
932-0100-01-0	Fiber - Multi Mode	with protection caps, 2 cores inside, LC to LC connector, 100m
932-0150-01-0	Fiber - Multi Mode	with protection caps, 2 cores inside, LC to LC connector, 150m
932-0200-01-0	Fiber - Multi Mode	with protection caps, 2 cores inside, LC to LC connector, 200m
932-0250-01-0	Fiber - Multi Mode	with protection caps, 2 cores inside, LC to LC connector, 250m
932-0300-01-0	Fiber - Multi Mode	with protection caps, 2 cores inside, LC to LC connector, 300m
931-0300-04-1	Fiber - Multi Mode	with protection caps, 4cores inside, LC to LC connector, 300m
931-0300-06-1	Fiber - Single Mode	with armour protection caps, 6cores inside, LC to LC connector, 300m

## Mini (MSP) Series-Distributors

Product Code	Item	Description
620-0216-01-0	MSP216	1 DVI In/2 DVI Out Distributor
620-0216-02-0	MSP216H	1 HDMI In/2 HDMI Out Distributor
620-0219-04-0	MSP319	1 SDI In/2 SDI Out Distributor
621-0219-04-0	MSP319-4	1 SDI In/4 SDI Out Distributor
920-0005-01-0	MSP Garage with PSU	Rack frame for MSP products with integrated power management
621-0316-02-0	MSP316D	1 HDMI2.0 In/2 HDMI2.0 Out Splitter or 2 HDMI 2.0 In/1 HDMI 2.0 Out

## STREAMING

- CAPTURE
- SWITCHER
- ENCODER
- CLOUD/DECODER

ASK Series  
Collaboration solutions

## PRO AV

D Series  
Digital Processors

X Series  
Universal Processors

M Series  
Mixing & Scaling

FLEX Series  
Mixed Signal Matrix

Q Series  
FLEX multi-signal matrix

1 Series  
Switcher/Scalers

T Series  
Control Consoles

Subito Series  
LED Control Solutions

UMS Series  
Media Solutions

RMS Series  
Monitoring Solutions

MSP Series  
Video Tools/Extenders  
Signal Converters  
Signal Distributors

Accessories

Software

Reference

Contact

## Contact Us



[www.rgblink.com](http://www.rgblink.com)



@RGLINK



/rgblink



+rgblink



/rgblink



rgblink



rgblink

### Inquiries

+86-592-577-1197

info@rgblink.com

[rgblink.com/contact-us](http://rgblink.com/contact-us)

### Global Support

support@rgblink.com

[www.rgblink.com/contact-support](http://www.rgblink.com/contact-support)

**RGblink  
Headquarters**  
Xiamen, China

6<sup>th</sup> Floor Weiye Building  
Torch Park Hi Tech Zone  
Huli

+86-592-577-1197

**China Regional  
Sales & Support**  
Shenzhen, China

11<sup>th</sup> Floor Baiwang Building  
5318 Shahe West Road  
Baimang, Nanshan

+86-755 2153 5149

**Beijing Region  
Office**  
Beijing, China

801, block 1b, Wangjing  
SOHO tower, Chaoyang  
District, Beijing

+010-8577 7286

**Europe Regional  
Sales & Support**  
Eindhoven, Holland

Flight Forum Eindhoven  
5657 DW

+31 (040) 202 71 83

*video {processing} for any scale*

WEB: [www.rgblink.com](http://www.rgblink.com) EMAIL: [sales@rgblink.com](mailto:sales@rgblink.com) PHONE: +86 592 5771197  
*Proudly designed and manufactured in **Xiamen** Hi Technology Zone, China*